



MODEL G1083, G1370, G1514/5 MORTISING ATTACHMENT INSTRUCTIONS

The mortising attachment enables you to cut square mortises in wood stock with a drill press and matched mortising chisel and bit. Material is removed by the mortising bit and the mortising chisel simultaneously squares the hole. The mortising attachment consists of a fence that mounts to the drill press table, two hook clamps that secure the work against the fence, an adjustable hold-down that keeps the work from raising when the chisel is raised and a chisel holder. The chisel holder has a split casting that clamps to the drill press quill. The chisel holder will accept a variety of mortising chisel sizes.

Securing Mortising Attachment to Drill Press

1. Swing the drill press table away, lower the quill and lock in place. Slide the chisel holder onto the quill and tighten the bolt on the chisel holder split casting.
2. Slide a desired mortising chisel into the end of the chisel holder and secure.
3. Slide the matching mortising bit through the chisel and into the drill chuck. The tip of the mortising bit should be at least $\frac{1}{16}$ " below the edge of the chisel.
NOTE: *It may be necessary to cut or grind the end of the bit that fits into the chuck so there will be proper clearance below the edge of the chisel. Secure the bit in the drill chuck.*
4. Fasten the fence assembly to the table. Ensure that the fence is positioned so it is square to the side of the chisel and set at the desired distance from the back of the chisel.



Mortising

1. Mark your mortise on the workpiece. Without drilling any stock, check the chisel position against the layout line. Make adjustments as required.
2. Remove the workpiece from under the mortising chisel and adjust the spindle stop to the desired depth. Crank the spindle down to make sure everything is clear.
3. Position the hook clamps against the side of the workpiece.
4. Adjust the hold-down so it is just above the workpiece and secure into position with the lock knob.
5. For best results, select a drill press speed of 650 to 1000 RPM.
6. Cut mortises in sequence as shown above. The distance between position 1 and 2, 2 and 4 and so on should be less than the width of the mortising chisel.

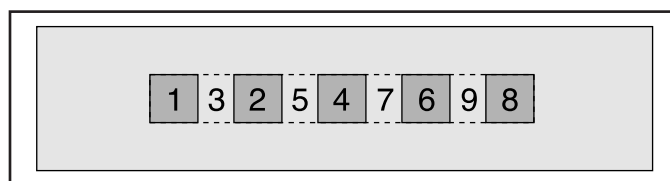

Sharpening

The mortising bit and chisel must be periodically re-sharpened. Sharpen mortising chisels with a round slipstone, working from the inside of the chisel to the edge. Do not sharpen the outside edge. Any burr on the outside edge of the chisel caused by sharpening the inside must be removed with a flat stone. Sharpen the mortising bit with a flat stone or triangular file.

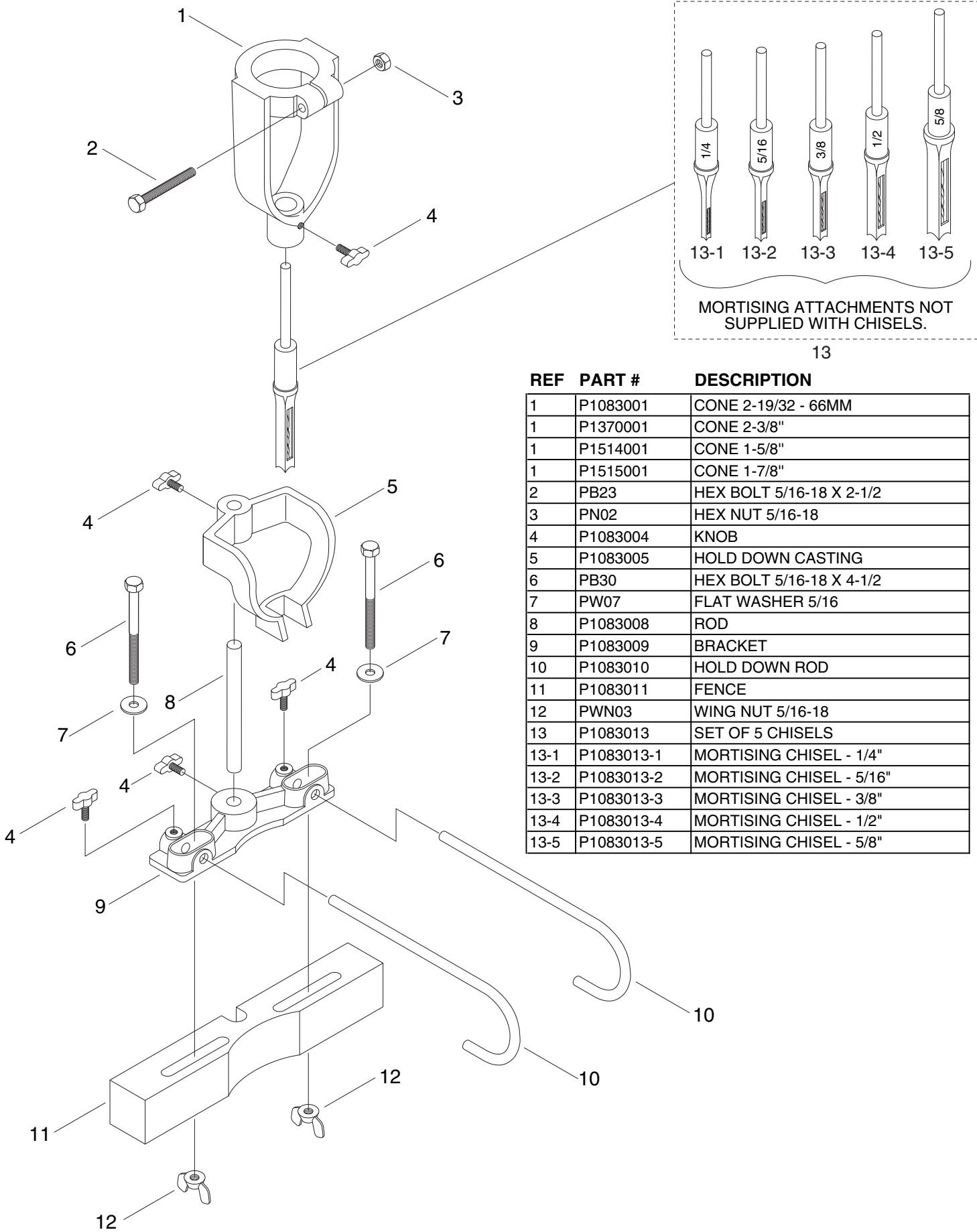

MORTISING ATTACHMENTS NOT SUPPLIED WITH CHISELS.

13

REF	PART #	DESCRIPTION
1	P1083001	CONE 2-19/32 - 66MM
1	P1370001	CONE 2-3/8"
1	P1514001	CONE 1-5/8"
1	P1515001	CONE 1-7/8"
2	PB23	HEX BOLT 5/16-18 X 2-1/2
3	PN02	HEX NUT 5/16-18
4	P1083004	KNOB
5	P1083005	HOLD DOWN CASTING
6	PB30	HEX BOLT 5/16-18 X 4-1/2
7	PW07	FLAT WASHER 5/16
8	P1083008	ROD
9	P1083009	BRACKET
10	P1083010	HOLD DOWN ROD
11	P1083011	FENCE
12	PWN03	WING NUT 5/16-18
13	P1083013	SET OF 5 CHISELS
13-1	P1083013-1	MORTISING CHISEL - 1/4"
13-2	P1083013-2	MORTISING CHISEL - 5/16"
13-3	P1083013-3	MORTISING CHISEL - 3/8"
13-4	P1083013-4	MORTISING CHISEL - 1/2"
13-5	P1083013-5	MORTISING CHISEL - 5/8"