

Notice

This Autogen CD Series Static Phase Converter is equipped with an electronic starting relay. When power is applied to the Autogen, you will hear a contactor close with a snap. Not to worry—it can sit that way indefinitely. Power consumption is less than that of a Christmas tree lamp (2 watts). The contactor will also snap closed when a motor is turned off. No problem—it is merely getting ready for the next start.

If you connect this converter at the load side of a motor starter it may chatter. While this will not harm anything, it will defeat the design of the unit, which is to close the starting contactor before power is applied to the motor. Any CD or CD-SD Series should be connected at the line side of the machine to be operated.

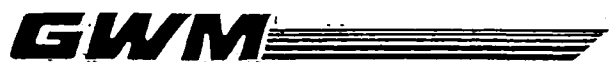

Installation Instructions Autogen CD-Series Phase Converters

Warning: Disconnect power before servicing or connecting any equipment! Electric shock can injure or kill you. This equipment should be installed in accordance with all local and National Electrical Codes.

1. Refer to the wire size chart (on reverse) for information pertaining to the motor you wish to operate. Choose one of the diagrams following to connect your converter. Single-phase power connects through L1 and L2. T3 is the capacitor phase. Be sure all equipment is grounded and do not ground T3.
2. When you connect your equipment be sure that any magnet controls are operated on the Single-Phase lines (L1 and L2). T3 (the capacitor phase) will not properly operate these controls. If your 3-phase machine has magnetic controls, these operate from two of the three machine input terminals. Leave off T3 and connect single phase, switching leads and trying the controls until you find the correct combination that makes the magnets work and the motor buzz. **Turn off power immediately** when you find the right pair. Connect T3 to the remaining machine input.
3. Turn the power on to the converter. You should hear an audible click in the Autogen as the start contactor engages.
4. Turn the machine on. **The red start light** on the Autogen should come on during motor starting only, and the motor should be up to speed in 3 seconds or less. **If the motor does not attain operating speed within 5 seconds, or if the red light stays on after the motor starts, shut power off immediately and review your installation.** (Troubleshooting Guide follows.)
5. If the machine runs backward, turn off all power and swap leads L1 and L2 from the converter to the machine. This will reverse the motor rotation.

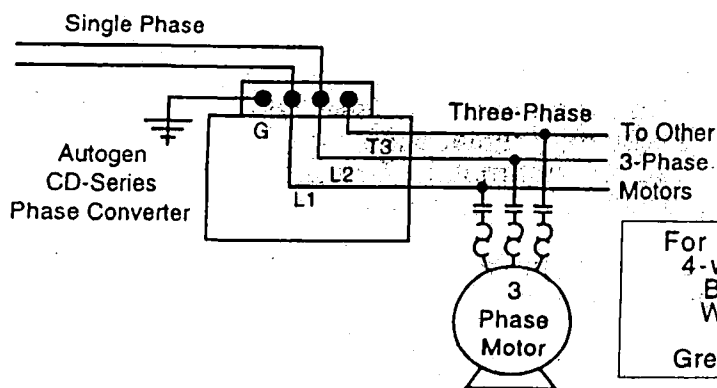

Either connection method may be used.

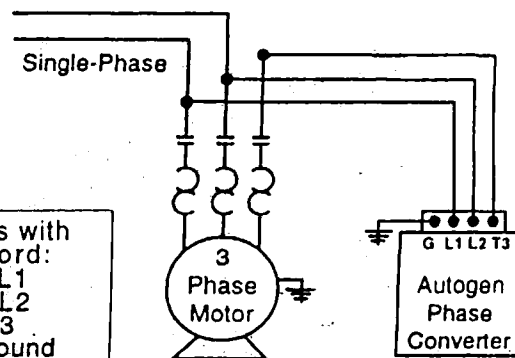

With this method you may use wire to converter that is one size smaller than the wire to the motor.

CHECKPOINTS: 230 VOLT SYSTEMS:

Converter voltages with motor "off" and converter "on."

L1 to L2 — 220-240v

L1 to T3 — Identical to L1-L2

L2 to T3 — 0 (Voltage only with motor on)

Converter voltages with both motor and converter "on."

L1 to L2 — 220-240v

L1 to T3 — 210-240v

L2 to T3 — 200-250v

Line-to-Neutral voltages mean nothing on a 3-phase system and should be ignored.

Line currents on this device will balance with motor operated at approximately 70% of full-load.

Wire sizes are for copper conductors. Use one size larger if aluminum wire. Since you are producing 3-wire power from a 2-wire supply, these guidelines should be strictly followed or poor motor performance will result. **Wire size should be increased for distances greater than 50 feet.**

3-Phase Motor HP	Locked Rotor Inrush @ 230v, Amps	Utility Transformer Req'd, kVA	Motor Service Amps	Wire Size	3-Phase Motor HP	Locked Rotor Inrush @ 230v, Amps	Utility Transformer Req'd, kVA	Motor Service Amps	Wire Size
1	30	5	15	14	15	180	15	100	4
2	40	5	20	12	20	210	22.5	100	3
3	60	5	30	10	25	280	37.5	125	2
5	80	5	40	8	30	325	37.5	150	1
7.5	110	7.5	60	6	40	360	50	150	1
10	135	10	80	4	50	395	50	200	1/0

Wire sizes for 230 volt operation. For 460 volt use wire for a motor 1/2 the size you are operating. (A 20 HP motor on a 460v. Autogen uses 10 HP 230v. wiring.)

IF YOU HAVE TROUBLE:

Remember that the Autogen you are using was tested on a motor, under load, before it was shipped. There is about a 98% chance that converter malfunction is a result of a problem in the installation or motor rather than the converter. First re-read the instructions and re-check your installation.

A. The converter must "click" when power is applied. "No click" means power is not reaching the converter.

B. The red light on the converter is a bellwether of operation. If you heard the "click" but the red start light does not come on when you attempt to start the motor, the converter may be too powerful for your motor, or the motor may be wired for a higher operating voltage. Ditto if the light flashes on-off when the motor starts. A bright red light at full motor speed may mean the start contactor has stuck.

C. If the red light is on bright but the motor does not come up to speed, your load may be too great for this device, or the machine may have a defective bearing. Try the motor with the drive belt removed.

D. If the red light cycles off-on while the motor runs at speed, the load is too great for an Autogen, or your single-phase supply wire or transformer is too small for the load. Check the L1-L2 voltage at the converter while the motor is running. If below 210 volts you have a supply problem. If voltage is good (230-250), you may:

1. Install a larger motor and Autogen, or use the idle motor method (see below);
2. On some machines such as air compressors, you may replace the motor (drive) pulley with a pulley 10% to 15% smaller to reduce the load on your motor. This will affect machine speed only slightly and usually solves the problem.

E. If the motor runs but the thermal protection trips: Set (adjustable) trip higher, or replace "heaters" with 1 or 2 sizes larger. This is a common problem on air compressors.

F. If the controls refuse to work on your machine, or "chattering" sometimes occurs on machine starting, you probably have T3 powering a magnetic starter coil or control transformer; or the coil or control transformer may be connected for higher voltage.

IDLE MOTOR METHOD:

The Autogen works better when another motor is run idle with one or more load motors. The idle motor acts as an "electrical flywheel," carrying the load along, and preferably will be 1 or 2 sizes larger than the load motor you are having trouble with. Using an idle motor will also enable you to operate 3-phase transformer loads, DC drives, etc. Connect as shown.

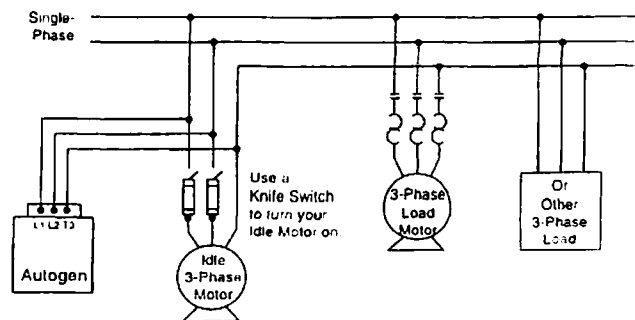

For 3-phase welders, battery chargers, etc., use an idle motor of 1 HP for every 3 amps of machine load. (Ex: A 200 amp welder that draws 22 amps takes a 7 1/2 HP idle motor, since 22 divided by 3 equals about 7.5.)

For Technical Assistance Call 660-376-9700