



2 Shelf Cart

MODEL G7113

INSTRUCTION SHEET

The Model G7113 2 Shelf Cart (**Figure 1**) features a 500 pound weight capacity and 5" solid rubber swivel wheels for high maneuverability.

Inventory (Figure 2)

A.	Lower Shelf	1
B.	Upper Shelf	1
C.	Handle Bracket (R).....	1
D.	Handle Bracket (L).....	1
E.	Handle	1
F.	Side Braces.....	4
G.	Fixed Wheels.....	2
H.	Swivel Wheels.....	2
I.	Bolt Bag.....	1
	—Hex Bolts M6-1 x 12	28
	—Hex Nut M6-1.....	32
	—Hex Bolts M6-1 x 15	4
	—Flat Washers 6mm	32
	—Lock Washers 6mm.....	32
	—Hex Bolts M10-1.5 x 15.....	16
	—Hex Nut M10-1.5.....	16
	—Lock Washers 10mm.....	16

Assembly

1. Attach the fixed casters to one end of the lower shelf (it has four holes in each bottom corner) and swivel casters to the other end with 10mm bolts, lock washers, and nuts.
2. Fasten a side brace to each corner of the lower shelf with 6mm bolts, flat washers, lock washers, and nuts. **Note:** Only tighten the bolts finger tight until assembly is complete.
3. Slide the upper shelf between the side braces and fasten the sides and one end with 6mm bolts, flat washers, lock washers, and nuts.
4. Place a handle bracket on each end of the handle. Thread 6mm bolts through the handle assembly, side braces and the top shelf. Secure the handle assembly with the remaining flat washers, lock washers, and nuts.
5. Make sure the cart is straight and the shelves are level, then tighten all of the bolts.

If you need additional help with this procedure, call our service department at: (570) 546-9663.



Figure 1. Model G7113.

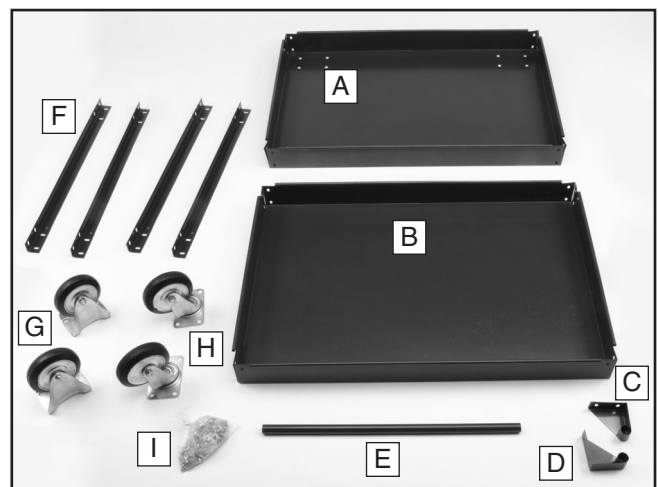

Figure 2. Inventory parts.

! WARNING

Children may climb into plastic bags and suffocate. Keep all plastic bags included in packaging out of the reach of children.

! CAUTION

Adult supervision is always required if this cart is being used by children.

G7113 Parts Breakdown and List

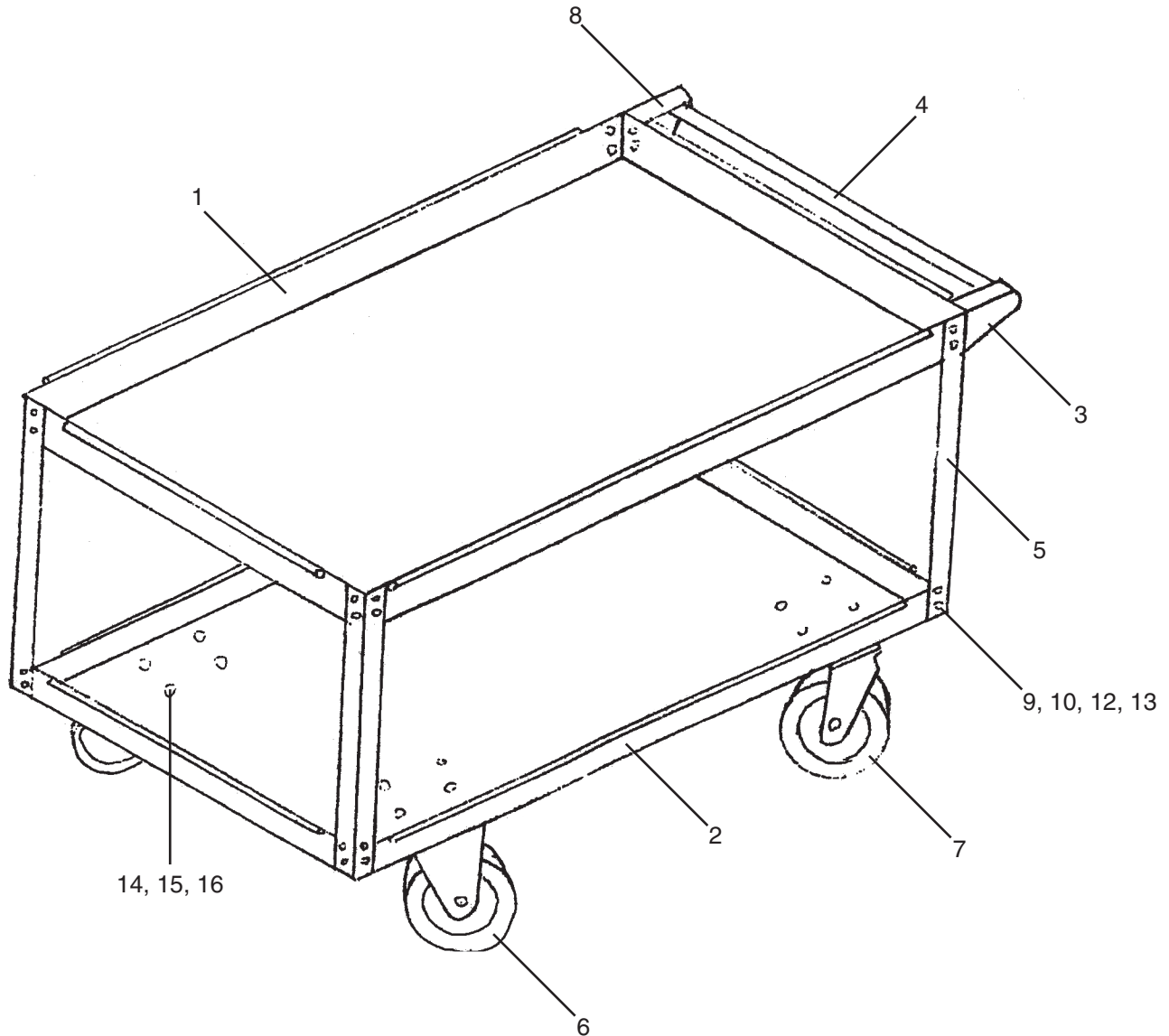

REF	PART #	DESCRIPTION
1	P7113001	UPPER SHELF
2	P7113002	LOWER SHELF
3	P7113003	HANDLE BRACKET (L)
4	P7113004	HANDLE
5	P7113005	SIDE BRACE
6	P7113006	FIXED WHEEL
7	P7113007	SWIVEL WHEEL
8	P7113008	HANDLE BRACKET (R)

REF	PART #	DESCRIPTION
9	PB02M	HEX BOLT M6-1 X 12
10	PN01M	HEX NUT M6-1
11	PB18M	HEX BOLT M6-1 X 15
12	PLW03M	LOCK WASHER 6MM
13	PW03M	FLAT WASHER 6MM
14	PB40M	HEX BOLT M10-1.5 X 15
15	PLW06M	LOCK WASHER 10MM
16	PN02M	HEX NUT M10-1.5

COPYRIGHT © JUNE, 2004 BY GRIZZLY INDUSTRIAL, INC. REVISED JUNE 2009 (CR)
**WARNING: NO PORTION OF THIS MANUAL MAY BE REPRODUCED IN ANY SHAPE
OR FORM WITHOUT THE WRITTEN APPROVAL OF GRIZZLY INDUSTRIAL, INC.**
#EW6385 PRINTED IN CHINA