

INSTRUCTION SHEET

- D2260 HEAVY-DUTY MINI-MOBILE BASE
- D2057 HEAVY-DUTY MOBILE BASE
- D2058 SUPER HEAVY-DUTY MOBILE BASE
- D2259 EXTENSION KIT FOR D2260/D2057
- D2246 EXTENSION RAIL KIT FOR D2058

This Shop Fox® Heavy-Duty Mobile Base and/or Extension Kit is designed to give you a stable and mobile platform upon which to mount machinery and equipment that have a variety of base dimensions and weights. The heavy-duty casters are arranged on outriggers, allowing the machine to sit as low as possible and yet be extremely stable. Swivel casters on two corners provide excellent maneuverability. The bolt pattern on the fixed caster side allows orientation of the wheels in either of two directions. The unique two-piece retractable feet offer an easy method of securing the position of the equipment. The Extension Kits allow you to modify the basic Mobile Base to accommodate long and narrow machines or equipment which has an extended table off one side. For specifications of each unit, please refer to the last page of these instructions.

PIECE INVENTORY - MOBILE BASES

Refer to the diagram for part identification.

1. Swivel Casters (2)
2. Fixed Casters (2)
3. Left Corner Bracket (1)
4. Right Corner Bracket (1)
5. Left Corner Brackets w/Leg Post (1)
6. Right Corner Brackets w/Leg Post (1)
7. Side Rails (4)
8. Rod w/Rubber Pad (2)
9. Threaded Rod w/Handle (2)
10. Bolts M8-1.25 x 20 (32)
11. Lock Washers 8mm (32)
12. Washers 8mm (32)
13. Nuts M8-1.25 (16)

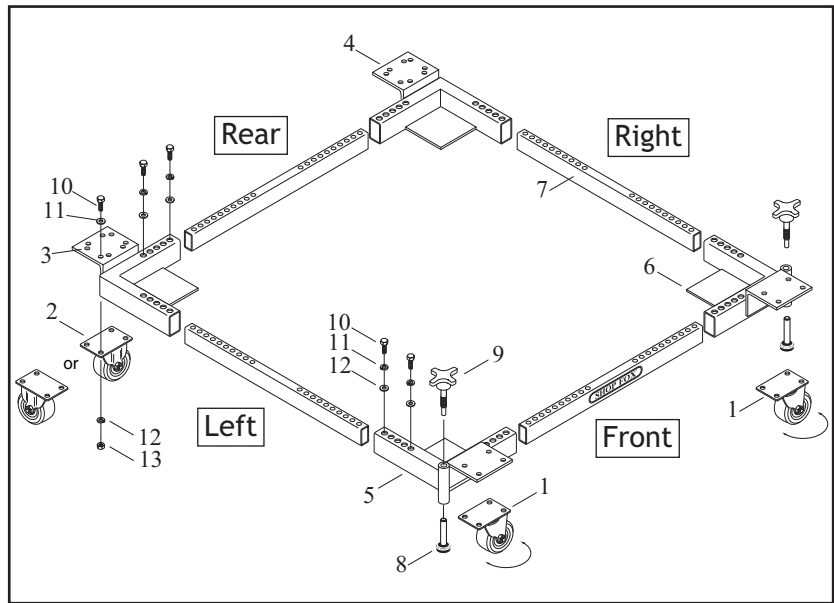

In the event that any non proprietary parts are missing (e.g. a bolt, nut or a washer...), please contact Woodstock International or, for the sake of expediency, replacements can be obtained at your local hardware store.

	<p>⚠ WARNING</p> <p>Do not use the Shop Fox® Heavy-Duty Mobile Base until you have fully read and understood this instruction sheet and completed the entire assembly procedure. Serious personal injury may occur.</p>
--	---

WARNING

SAFETY INSTRUCTIONS FOR THE MOBILE BASE

1. **NEVER use the machine when the locking feet are in the raised position.** Always make certain that the two retractable feet are down (the knobs should be turned at least an additional half turn after initial contact with the floor) and the Mobile Base is securely positioned before operating any machine on the base. Attempting to use the machine when unsecured can result in loss of control of the workpiece which can cause injury.
2. **PUSH the machine and base at a point as low as possible to avoid tipping.** Some machines may be somewhat top-heavy (e.g. drill presses or bandsaws). Be sure to push the machine and Mobile Base assembly at the lowest possible point to avoid tipping the machine over. Pushing the base itself is the optimal method of moving.
3. **Avoid potential pinch points when moving the machine.** Keep your hands clear of any potential interference between the machine you are moving, other equipment and racks or tables which may protrude into the path of travel.
4. **Use an assistant when moving a large piece of equipment.** Since visibility can often be obstructed when moving a large piece of equipment, it is helpful to have an assistant available to help guide the machine and to be on the lookout for potential obstructions.
5. **Test for stability after placing the machine in its new position.** Put the locking feet down and push on the machine at several locations and in different directions, making sure it is not rocking or off balance.

ASSEMBLY INSTRUCTIONS

Tools Required

Tape Measure..... 1
Wrenches 13mm or 1/2" 2

1. Measure the footprint of the machine to be mounted on the base, including anything protruding within a 2" high band around the base of the machine. The base of the machine will sit on four corner pads that are bounded by 2" rectangular tubing. Therefore, anything extending from the base within that band may interfere. **See Figure 1.**
2. Determine the assembly configuration you want to use and how you want the machine oriented on the base. Consider the direction the machine will be moved. It is generally most convenient to have the swivel casters positioned on the side from which the machine will be typically pushed. This provides the greatest degree of maneuverability and control. Also, if a long and narrow configuration is required, such as with a jointer or edge sander, it is best to have the swivel casters mounted on one of the short ends. Care should be taken to ensure the casters will not interfere with the normal operating position of the machine. Also, check the machine weight specification to make certain it does not exceed the load limit of the Mobile Base. See the last page for load limits of your mobile base.

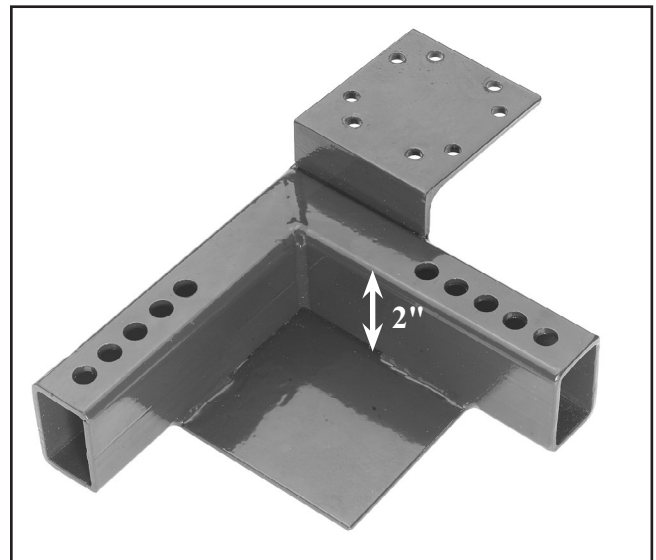

Figure 1. Corner bracket.

3. If the machine you wish to mount on the base is extremely heavy (or where it may be difficult or dangerous to attempt to lift the machine onto the base after assembly), it may be more convenient to build the base around the bottom of the machine. To do this it will be necessary to raise the machine so it is at least 2" off of the floor. This can be accomplished by placing the machine on blocks by lifting up first one side, then the other. Take care to avoid placing the blocks where they will interfere with the plates the machine will rest on once it is on the base.

⚠ WARNING

Lifting a heavy piece of equipment should be done carefully and with the proper equipment. The variety of machine configurations and weights make it impossible to thoroughly describe every lifting situation here. If placing the machine on blocks, make certain they are capable of supporting the weight and are properly placed. **Serious personal injury may occur.**

4. Mount the two fixed casters on the corner brackets which have the eight hole pattern, making sure to orient the casters according to the configuration you selected. Use four (4) bolts through the top of outrigger with the caster mounting plate underneath. Secure with a washer, lock washer and nut. Similarly, mount the two swivel casters on the other two corner brackets. The swivel casters should always be mounted on the corners which have the threaded post. **See Figure 2.** Tighten each caster mounting.

5. Take the four corner brackets and lay them on the floor or around the machine if it is raised. Make sure the corner brackets with the swivel casters are located where you want them. Take each side rail and slide it inside the corner bracket tubing. If you are using the Extension Rail Kit on the D2058, replace two of the standard side rails with the longer ones provided in the kit. If you are using the D2259 Extension Kit, determine which side of the base needs to have the extension bar mounted. Replace the standard rail with the one included in that kit, then refer to **page 5** for further instructions.

The threaded holes of the rails and the non-threaded holes of the corner brackets should be facing up. Adjust the assembly so the inside dimension is the same as you determined in **Step 1**. Do not install any fasteners yet. **See Figure 3.**

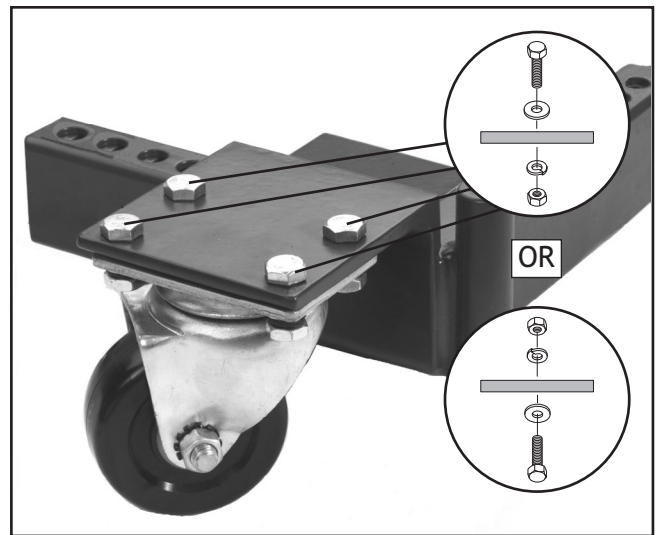

Figure 2. Swivel caster on threaded post corner.

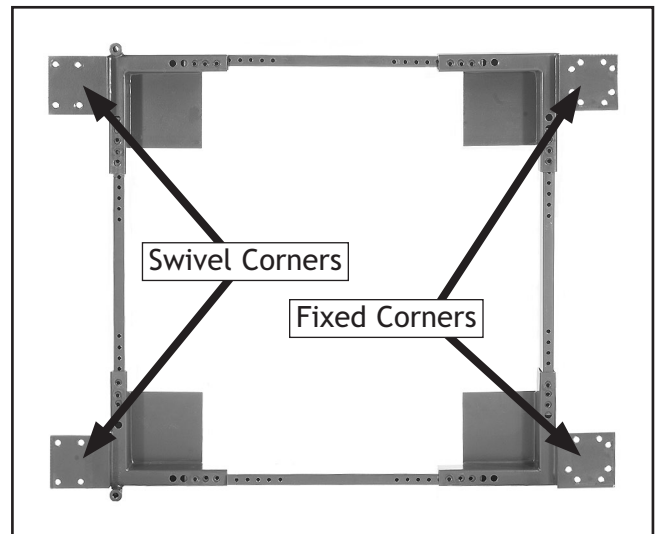

Figure 3. Layout of Mobile Base components.

6. Extend the assembly just enough so that the holes in the corner brackets align with the threaded holes in the side rails. Install two (2) bolts on each side of each corner of the base. Use a flat washer and lock washer with each bolt. The bolts go through the clearance hole on the corner bracket into the threaded hole in the side rail.

If using the Mobile Base near its maximum size, make certain that a minimum of two holes at each of the side-rail-to-corner-bracket connections are assembled as shown in **Figure 4**.

Continue bolt installation for each corner bracket. **Tighten all bolts.**

⚠ WARNING

Each side-rail-to-corner-bracket connection must have a minimum of two (2) threaded bolts installed. Do not load any machine onto the base until all of these bolts have been installed and tightened. Loading a machine onto the base before completing assembly can result in the machine falling or tipping over. If this occurs, hands or feet can be trapped under the machine. **Serious personal injury may occur.**

7. Take the rod with the attached black rubber pad and insert it into the bottom of the leg post. Now take the threaded rod with the knob and thread it into the top of the leg post. See **Figure 6**. The rod on which the foot pad is mounted is magnetic, and when the threaded knob comes in close enough proximity, it will pick up the lower rod. With the Mobile Base sitting on the floor, adjust the knob down so the pad is not in contact with the floor. Do this same procedure for the post on the other corner.



Figure 4. Side rail at maximum extension.

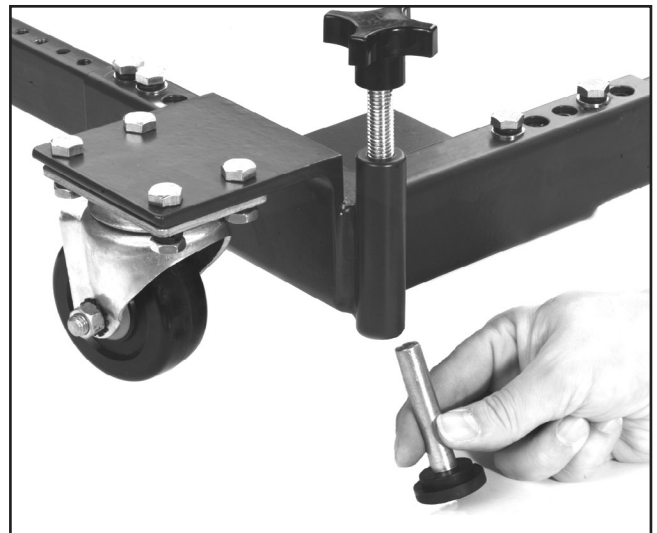

Figure 5. Assembly of foot pad and knob.

INSTRUCTION SHEET

D2259 MOBILE BASE EXTENSION KIT

The Shop Fox® Mobile Base Extension Kit is designed to easily install onto either the D2057 or D2260 Mobile Bases to provide support for extension tables. When this kit is added to your existing Mobile Base it will provide a stable platform for the combined machine and extension table unit. Swivel casters on the extension channel maintain the excellent maneuverability of the Mobile Base. The extension unit can be modified for maximum table leg distances ranging from 28½" to 45¾".

PIECE INVENTORY

Compare the parts received to the drawing at the right:

1. Swivel Casters (2)
2. Leg Support Channel
3. Extension Bar
4. Base Side Rail with Mounting Bracket
5. Mounting Bracket
6. Rod w/Rubber Pad (2)
7. Threaded Rod w/Handle (2)
8. Bolts M8-1.25 x 20mm (14)
9. Lock Washers M8 (14)
10. Washers M8 (14)
11. Nuts M8-1.25 (8)

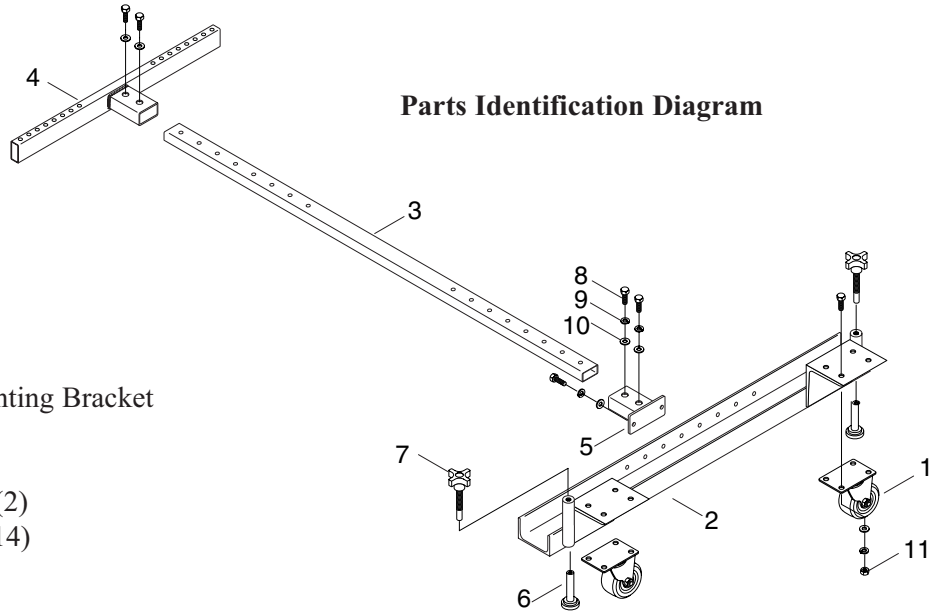

In the event that any non proprietary parts are missing (e.g. a bolt, nut or a washer...), please contact Woodstock International or, for the sake of expediency, replacements can be obtained at your local hardware store.

ASSEMBLY INSTRUCTIONS

Tools Required: Tape Measure, Hacksaw, and 14mm or ½" wrenches (2)

1. Follow the instructions on the preceding pages for the assembly of the D2057 or D2260 Mobile Base. When you are installing the side rails, determine which side of the Mobile Base the Extension Kit will be mounted on. Replace the standard side rail on that side with the rail included in this kit (the new rail has a rectangular mounting bracket welded to it). If you are installing this kit on the D2260 Mini Mobile Base, it will be necessary to cut off the ends of the new side rail so it is the same length as the rail you are replacing. **Be sure to cut an equal amount off of each end of the extension bar.** Use a standard hacksaw and mount the bar firmly in a vise or clamp to a bench top to do the cutting.

	<p>⚠ WARNING</p> <p>Do not use the Shop Fox® Mobile Base Extension Kit until you have fully read and understood this instruction sheet and completed the entire assembly procedure.</p>
--	--

2. Assemble the swivel casters to the outrigger pads located on the extension channel, using four bolts, washers, lock washers and nuts. Assemble the locking knob and foot pad in the same manner they were installed on the Mobile Base.
3. If not already assembled, install the extension table on the machine. Place the extension channel assembly under the legs of the installed extension table. **See Figure 6.** The two swivel casters must be positioned so they are on the outside-edge. Center the table legs along the length of the channel. Measure the distance from the outer edge of the side rail to the side of the extension channel. The extension bar should be cut to this length less approximately $\frac{1}{2}$ " (this allows for alignment of the holes). Locate your cut so that it is centered between two of the threaded holes. Use a hacksaw and mount the bar firmly in a vise or clamp to a bench top to do the cutting.

Always be sure to leave at least two of the threaded holes on each end of the extension bar. It may be necessary to remove a length from each end to insure there will be at least two threaded holes on each end. **Be careful not to cut the bar too short.**

4. Slip one end of the extension bar into the bracket on the Mobile Base side rail. On the other end, position the mounting bracket onto the end of the bar. Lower the bar down into position and align the bracket with the threaded holes on the side of the channel. **See Figure 7.** It may be necessary to slightly reposition the channel assembly back and forth to align the bracket with the holes. Assemble the mounting bracket to the side of the extension channel using two bolts. The holes in the side of the channel are threaded so only a washer and lock washer are required.
5. Secure the extension bar into the two brackets with two bolts, washers and lock washers through each bracket into the threaded holes on the extension bar.
6. **Tighten all bolts.** Check the extension table to make sure it is level with the machine table surface. It may be necessary to slightly adjust the leg length to assure the extension table legs sit firmly on the channel.

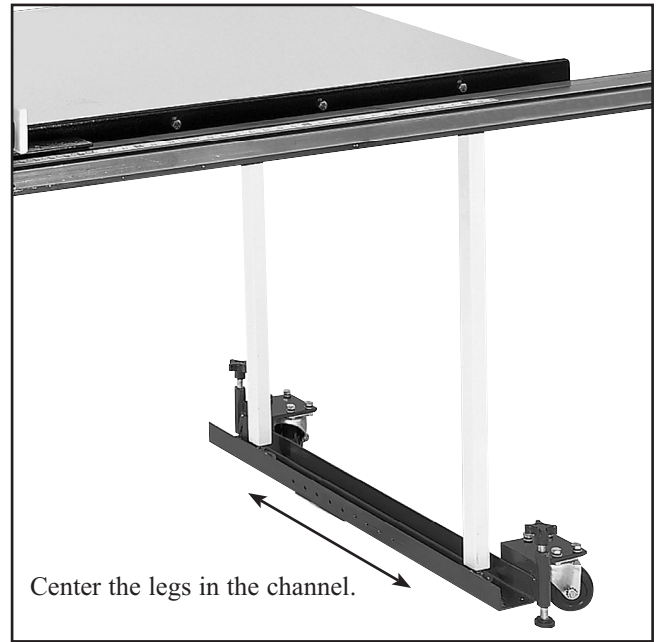

Figure 6. Extension table legs on channel.

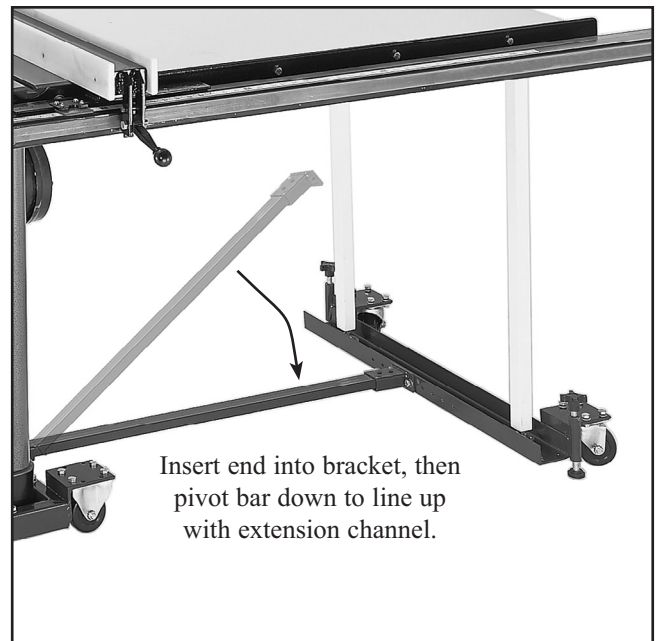

Figure 7. Attaching extension bar.

USING YOUR SHOP FOX® HEAVY-DUTY MOBILE BASE

Mounting Equipment On the Mobile Base

After completing assembly of the Mobile Base, you are now ready to mount the desired machine onto the base (unless you have built the base around a supported machine). Great care should be taken when lifting the equipment. Use the appropriate accessory equipment (chain hoist, engine lift, hydraulic jacks, etc.) depending upon the weight and configuration of the machine. Make sure you orient it onto the base in the desired manner before setting it onto the corner bracket pads. Be sure the machine will clear the side rails and corner brackets all the way around the base of the machine. Keep hands and fingers clear during this process!

WARNING

Lifting a heavy piece of equipment should be done carefully and with the proper equipment. The variety of machine configurations and weights make it impossible to thoroughly describe every lifting situation here. If placing the machine on blocks, make certain they are capable of supporting the weight and are properly placed. **Serious personal injury may occur.**

Once the Mobile Base is supporting the full weight of the machine, check to make sure the machine is properly seated on the pads, and that there is no sign of stress or deflection in the Mobile Base. If there is, immediately remove the machine from the base and check that all fasteners have been tightened and that the base is properly assembled. If this does not solve the problem, double check the weight specification of the machine and make certain it does not exceed the load limit of the Mobile Base (600 lbs. for the D2260 and D2057, 1200 lbs. for the D2058).

WARNING

Before moving the machine and Mobile Base, make certain that the pathway is totally clear of any hoses, wires, tools or shop debris. Any abrupt impact with anything in the path of travel can lock a wheel and cause the machine to fall over. Be sure to disconnect the machine from any power supply or dust collection system before moving. **Serious personal injury may occur.**

Moving Equipment Around On the Base

To prepare to move the machine and Mobile Base, first turn the two retractable feet knobs counterclockwise so that they are clear of the floor by at least $\frac{1}{8}$ ". If the floor is very uneven it is best to retract them completely. Push on the machine from a point which is as low as possible to avoid tipping the machine. The best control is achieved by pushing on the side of the base which has the swivel casters. Be sure the pathway is clear of all obstructions.

After repositioning the machine, screw down the two retractable feet until they touch the floor surface. Then turn the knobs at least an additional one-half turn. This will assure that the major load of the machine is on the feet rather than the casters. Check the machine to make sure it is stable in its new location. Make certain the machine is clear of interference with anything else before connecting the power and turning it on.

IF YOU NEED ASSISTANCE

We hope you will find that your Shop Fox® Heavy-Duty Mobile Base is easily assembled and put to use. Should you have any questions about this product, please contact the dealer where you purchased it, or you can contact the Woodstock International Technical Department at 1-800-840-8420 between the hours of 7:00 am to 5:00 pm PST.

**Shop Fox® is a registered trademark of
Woodstock International, Inc.**

SPECIFICATIONS

MOBILE BASES

	<u>D2260</u>	<u>D2057</u>	<u>D2058</u>
Inside Dim-Minimum	10½" x 14½"	19" x 20½"	18" x 24½"
Inside Dim-Maximum	21½" x 17"	29½" x 29½"	28½" x 33½"
Max Weight Capacity	600 lbs	600 lbs	1200 lbs

EXTENSION KITS

	<u>D2246</u>	<u>D2259</u>
Inside Dim-Minimum	33½" x 19"	Minimum Ext Length 28½"
Inside Dim-Maximum	33½" x 44¼"	Maximum Ext Length 45¾"
Max Weight Capacity	1200 lbs	Maximum Leg Span 32"