



ALUMA-CLASSIC™ FENCE

W1716 & W1720



INSTRUCTION MANUAL

Phone: 1-360-734-3482 • On-Line Technical Support: tech-support@shopfox.biz

COPYRIGHT © APRIL, 2004 BY WOODSTOCK INTERNATIONAL, INC.
WARNING: NO PORTION OF THIS MANUAL MAY BE REPRODUCED IN ANY SHAPE OR FORM WITHOUT
THE WRITTEN APPROVAL OF WOODSTOCK INTERNATIONAL, INC.

Printed in Taiwan

Contents

INTRODUCTION	2
About-Your-New-Aluma-Classic™-Fence	2
Woodstock-Service-and-Support	2
Unpacking	3
Get-To-Know-Your-Fence	3
Location-of-Controls	3
ASSEMBLY	4
Inventory	4
W1716-Installation	5
W1720-Installation	6
Installing-Metal-Extension-Wings	8
ADJUSTMENTS	9
Fence-to-Blade	9
Scale-Installation-And-Adjustment	10
PARTS	11

USE THE QUICK GUIDE PAGE LABELS TO SEARCH OUT INFORMATION FAST!





INTRODUCTION

About Your New Aluma-Classic™ Fence

Your new **SHOP FOX®** Model W1716/W1720 Aluma-Classic™ Fence is specially designed to provide many years of trouble-free service. Close attention to engineering detail, ruggedly built parts, and a rigid quality control program assure safe and reliable operation.

The Aluma-Classic™ Fence features an extruded aluminum and steel construction, utilizing a sturdy T-shape design that fits most table saws easily. The Model W1716/W1720 also features a single cam locking lever, magnified cursor lens and standard 57" rails. The Model W1720 is exactly the same as the Model W1716 except it features 79" extruded aluminum rails for wide panel cutting up to 50" right of the blade.

For more features and details, refer to the **Specifications** sub-section in this manual.

Woodstock International, Inc. is committed to customer satisfaction in providing this manual. It is our intent to include all the information necessary for safety, ease of assembly, practical use and durability of this product.

If you need the latest edition of this manual, you can download it from <http://www.shopfox.biz>.
If you still have questions after reading the latest manual, or if you have comments please contact us at:

Woodstock International, Inc.
Attn: Technical Support Department
P.O. Box 2309
Bellingham, WA 98227

Woodstock Service and Support

We stand behind our machines! In the event that a defect is found, parts are missing or questions arise about your machine, please contact Woodstock International Service and Support at 1-360-734-3482 or send e-mail to: tech-support@shopfox.biz. Our knowledgeable staff will help you troubleshoot problems, order parts or arrange warranty returns.

Get To Know Your Fence

For proper operation it is important to know your machine and its components. Please take the time to learn the features shown in **Figure 1 & 1a** below.

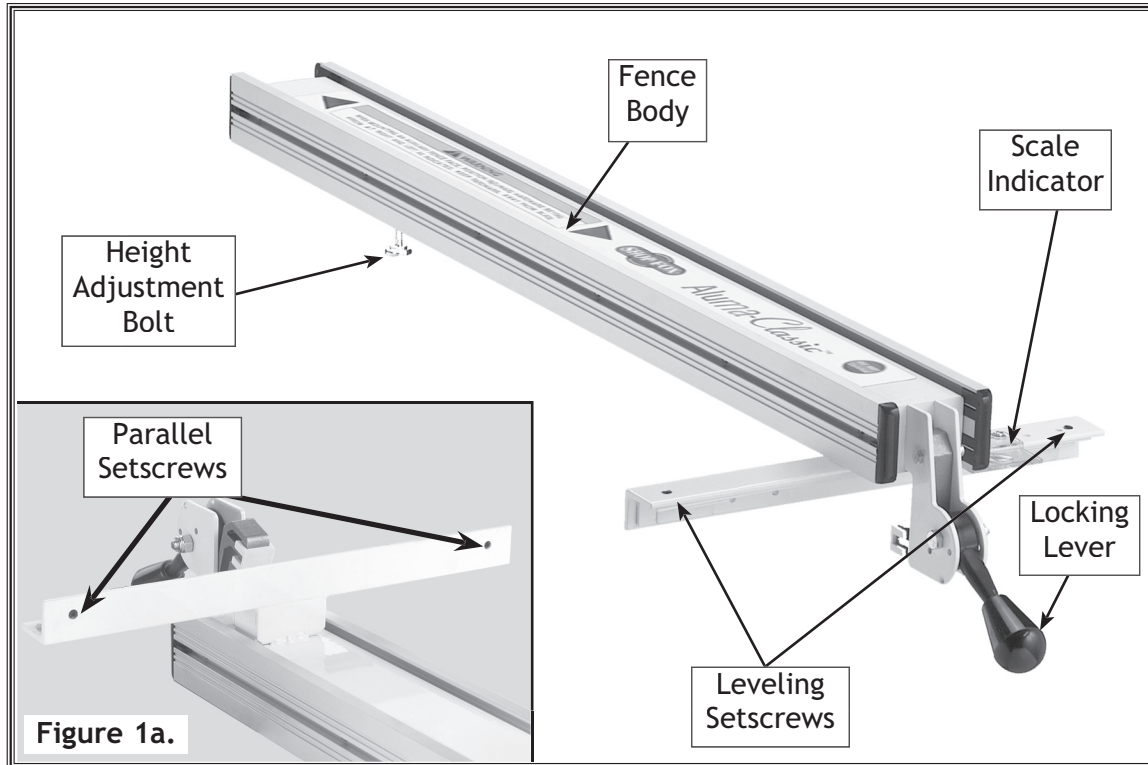

Figure 1. Fence features.

Unpacking

The SHOP FOX® W1716/W1720 has been carefully packaged for safe transporting. If you notice the fence has been damaged, please contact Woodstock International Service and Support at 1-360-734-3482 or send e-mail to: tech-support@shopfox.biz

Fence Controls

Take the time to familiarize yourself with the features of your new SHOP FOX® Model W1716/W1720 Aluma-Classic™ Fence. They will be frequently mentioned throughout the instructions in this manual. **Figure 1** points out the key features and their locations.

ASSEMBLY

Inventory

The following is a description of the main components shipped with the **SHOP FOX®** Model W1716/W1720 Aluma-Classic™ Fence. You should lay the components out to easily identify them. The inventory for the Models W1721 and W1722 are also listed below.

If any parts are missing, find the part number in the back of this manual and contact Woodstock International, Inc. at 360-734-3482 or at: tech-support@shopfox.biz

Model W1716:

- Aluma-Classic™ Fence 1
- Fence Handle Knob 1
- Fence Scale Assembly 1
- 57" Fence Rails 3
- 30" Scale 1
- W1716 Hardware Bag 1

Model W1720:

- Aluma-Classic™ Fence 1
- 79" Fence Rails 2
- Rail End Caps 4
- Phillips Head Tap Screw #8 x 3/8" 4
- Legs 2
- 50" Scale 1
- Sheet Metal Wings 3
- W1720 Hardware Bag 1

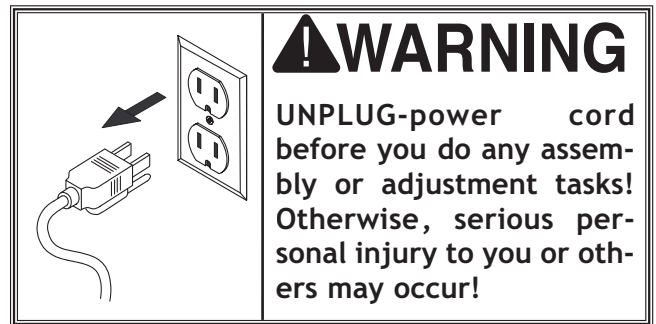
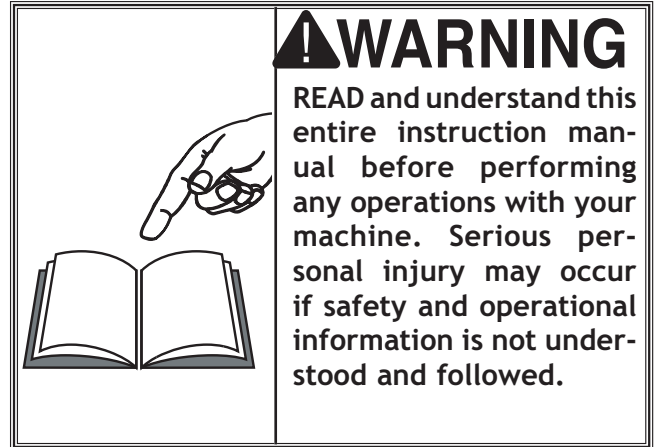

ASSEMBLY

W1716 Installation

The SHOP FOX® W1716 Aluma-Classic™ Fence comes in a box with its own hardware bag.

W1716 Hardware Bag Contents:	Qty
• Cap Screws $\frac{5}{16}$ "-18 x 1"	4
• Flat Washer $\frac{5}{16}$ "	4
• Flat Washer $\frac{1}{4}$ "	6
• Hex Nuts $\frac{5}{16}$ "-18	4
• Hex Bolts $\frac{1}{4}$ "-20 x $\frac{3}{4}$ "	6
• Flat Head Phlp Screws $\frac{5}{16}$ "-18 x 1"	4
• Hex Key 6mm	1
• Hex Key 4mm	1

To install the fence rail to the table saw, do these steps:

1. Install the rear rail bracket (long angle iron) to the back side of the table (Figure 2), with the four $\frac{5}{16}$ " cap screws. The holes in the extension wings are not threaded and require $\frac{5}{16}$ " nuts and washers to secure them.
2. Install the front rail bracket (Figure 3) with the $\frac{5}{16}$ "-18 x 1" flat head Phillips screws.
3. Use $\frac{5}{16}$ " washers and nuts to secure the rail to the extension table holes.
4. Align the fence rail (rectangular tubing) threaded holes over the front rail bracket holes and secure it in place with the provided six $\frac{1}{4}$ "-20 x $\frac{3}{4}$ " hex bolts as shown in Figure 4.



Figure 2. Rear fence rail bracket.



Figure 3. Front fence rail bracket.



Figure 4. Installing fence tubing.

To install the rip fence to the table saw, do these steps:

1. Thread the handle knob onto the fence locking handle.
2. Make sure the handle is in the unlocked "UP" position before placing the fence on the rails.
3. Check to see that the fence clears the table surface throughout its range of travel, and increase or decrease the height between the fence and table by adjusting the bolt shown in Figure 5.
4. Install the clear scale indicator to the right of the fence with the #10-24 x 3/8" Phillips head screws and #10 washers (Figure 6).

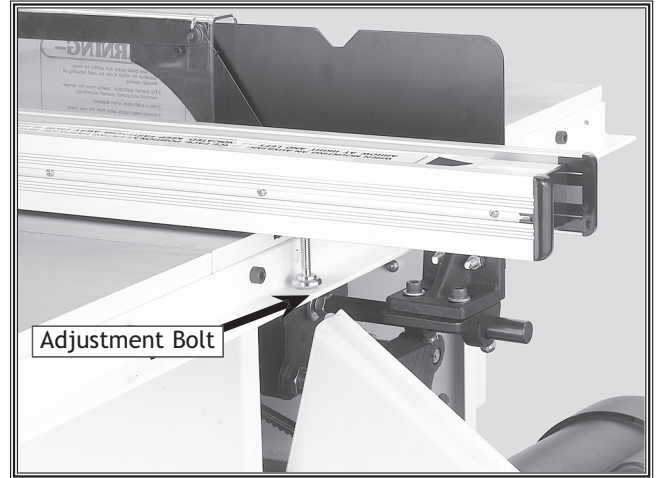

Figure 5. Adjustment bolt.

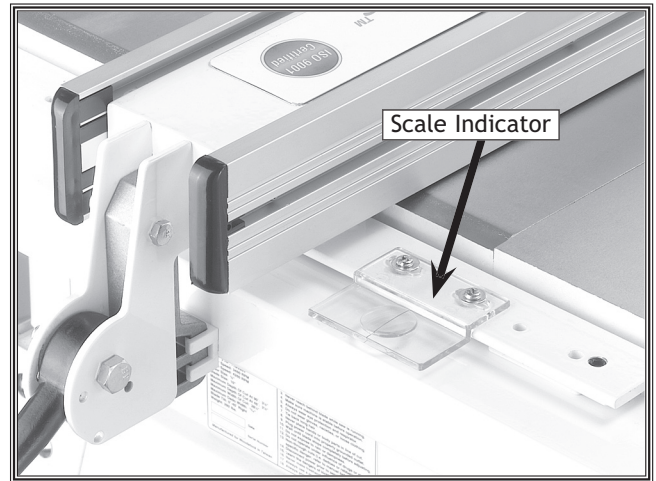

Figure 6. Scale indicator.

W1720 Installation

The SHOP FOX® W1720 Aluma-Classic™ Fence with 79" rails mounts to most table saws. Figure 7 shows the inventory for the W1720 (Fence not shown).

W1720 Hardware Bag Contents:	Qty
• Flat Washer 1/4"	8
• T-Bolt M6-1 x 30	8
• Hex Nut M6-1	8
• Flat Washer 5/16"	10
• T-Bolt 5/16"-18 x 3/4"	10
• Hex Nut 5/16"-18	10

To install the W1720 fence rails to the table saw, do these steps:

1. Remove the fence, the standard rails, and the blade guard that came with the table saw, if they are installed.
2. In the front and back edge of the table, insert eight M6-1.0 x 30 T-bolts (four on each side) through the larger threaded holes, and install the flat washers and nuts on each bolt. See Figure 8.



Figure 7. Extension rail inventory.

3. Insert two $\frac{5}{16}$ "-18 x $\frac{3}{4}$ " T-bolts in the right table wing, and two into the edge of the left table wing, and install the flat washers and nuts on each bolt. See **Figure 8**.
4. Tighten all nuts until there is a gap of approximately $\frac{3}{16}$ " to $\frac{1}{4}$ " between the T-bolt and the table and wing edges.
5. Slide the extension rail over the T-bolts as shown in **Figure 1** until the rail is flush with the end edge of the left table wing.
6. Tighten all hex nuts.
7. On each leg flange fasten two $\frac{5}{16}$ "-18 x $\frac{3}{4}$ " T-bolts, flat washers, and the nuts; then slide the legs onto the rails as shown in **Figure 9**.
8. Tighten the hex nuts to secure the legs to the rails, and secure the rail end caps with the Phillips head screws.
9. Insert two $\frac{5}{16}$ "-18 x $\frac{3}{4}$ " T-bolts into the start switch mounting slot (see **Figure 8**), and position the start switch mounting bracket to the underside of the rail, and secure it with the washers and nuts.
10. Install fence, and adjust rails to fine-tune the mounting alignment of the rails and legs.

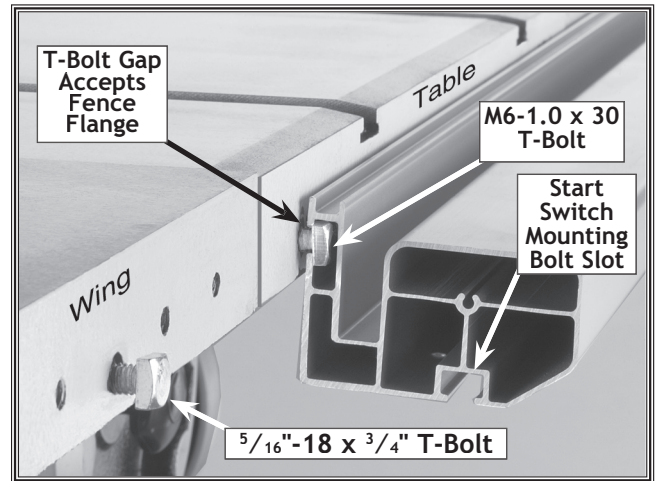

Figure 8. Front rail being slid onto T-bolts.



Figure 9. Sliding rail leg into table.

Installing Metal Extension Wings

The SHOP FOX® Heavy-Duty Metal Extension Wings (Figure 10) can be installed on the Model W1720 79" rails.

Hardware Bag Contents:	Qty
• Flat Washer $\frac{5}{16}$ "	12
• T-Bolt $\frac{5}{16}$ " -18 x 1"	12
• Hex Nut $\frac{5}{16}$ "-18	12

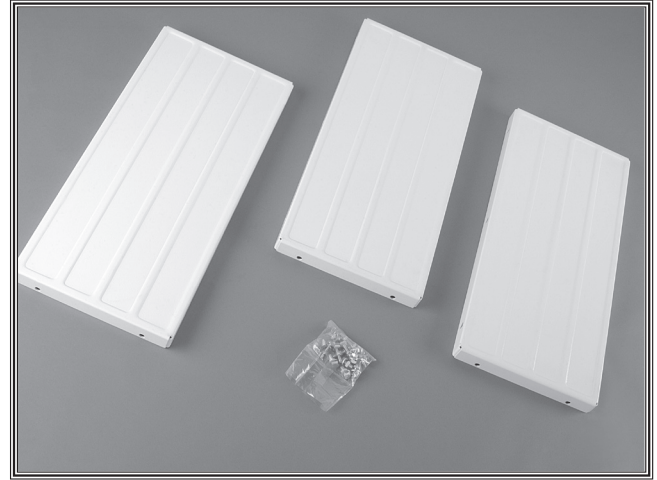

Figure 10. Extension wing box inventory.

To install the W1720 extension wings, do these steps:

1. Loosely install the T-bolts, washers and hex nuts into the short sides of the extension wings.
2. Insert the T-bolt heads into the rail T-slots as shown in Figure 11.
3. Slide the tables into place as shown in Figure 12. Note—*The tables slide into place easily if you lift up while you slide them into place.*
4. Place a straightedge across the top of the wings, and tighten the nuts behind the edge of the extension wings to secure the wings in place.

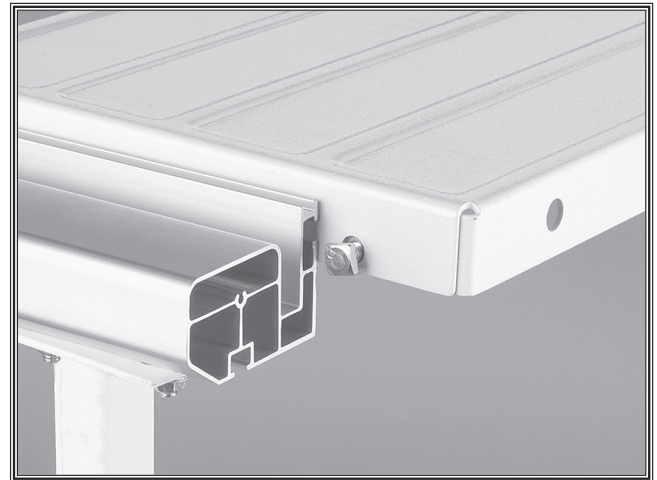

Figure 11. T-bolt and rail T-slot.

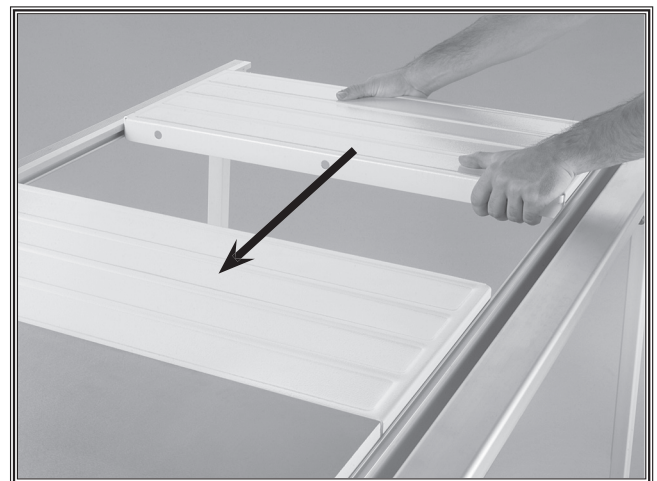

Figure 12. Sliding in the wings.

ADJUSTMENTS

The SHOP FOX® W1716/W1720 Aluma-Classic™ Fence requires little adjustment since most of the features are built in at the factory. The primary adjustment is to position the fence so it is parallel to the saw blade.

Fence Parallelism

If your table saw has been properly adjusted, the saw blade should be parallel to the miter slot. Refer to your table saw manual for the proper procedure to check and adjust the saw blade to the miter slot correctly.

To adjust the SHOP FOX® Aluma-Classic™ Fence parallel with the miter slot, do these steps:

1. **UNPLUG THE TABLE SAW!**
2. Align the edge of the fence with the edge of the miter slot.
3. Lock the fence and check the alignment between the left edge and the miter slot.
4. Adjust the setscrews shown in **Figure 13** to adjust the angle of the fence. Note— *The left setscrew will move the fence left and the right setscrew will move the fence right.*
5. Adjust the fence until the back end falls $\frac{1}{64}$ " away from the miter slot so the workpiece clears the opposite end of the saw blade without binding. This is called "lead" (pronounced *lead*).

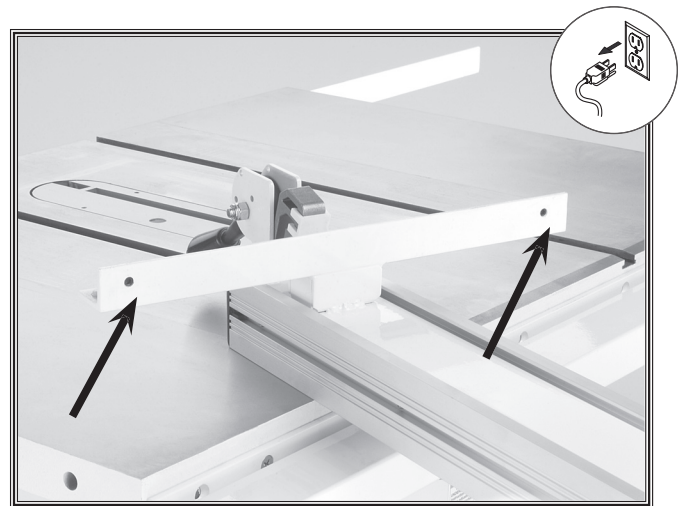
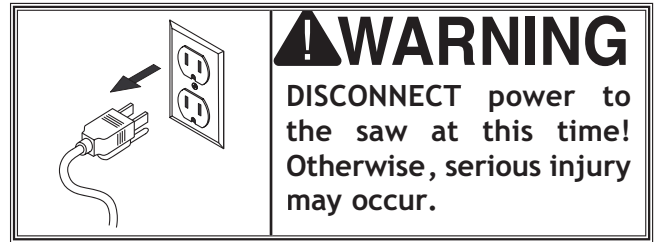

Figure 13. Fence adjustment setscrews.

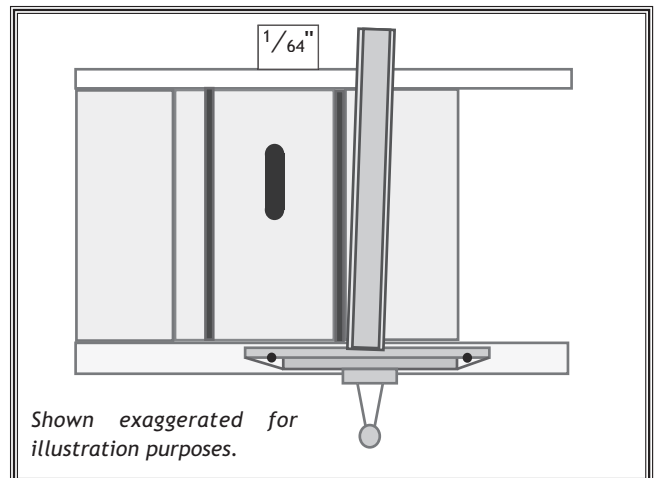

Figure 14. Lead adjustment.

! WARNING

KICK-BACK! DO NOT cut on the left side of the blade if the fence lead is adjusted for cutting on the right side of the blade. Re-adjust the lead when changing the side of the blade you are cutting on.

Scale Installation & Adjustment

The self-adhesive scale provides fast and accurate fence positioning. It is best to install the scale after all other adjustments in this section have been made. **Figure 15** shows the scale properly installed on the front rail.

To install the scale indicator, do these steps:

1. **UNPLUG THE TABLE SAW!**
2. Raise the blade to its maximum height.
3. Position the fence against the right side of the blade.
4. Carefully place the scale along the front rail about $\frac{1}{2}$ " away from the edge and underneath the scale indicator. Note—*Do not stretch the tape! This will cause inaccurate cuts.*
5. Position the "0" mark on the scale under the cursor hairline and secure the scale to the rail.
6. Adjust the cursor left or right so the hairline is directly over the "0" mark on the scale.
7. Make a test cut then measure the thickness of your test board.
8. Fine tune the hairline indicator to correspond with the actual test board thickness. This method accounts for any vibration or wobble that may be present in the spinning blade.

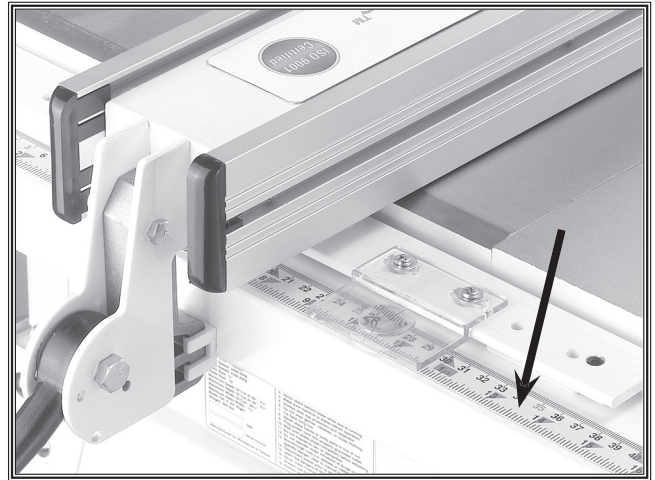
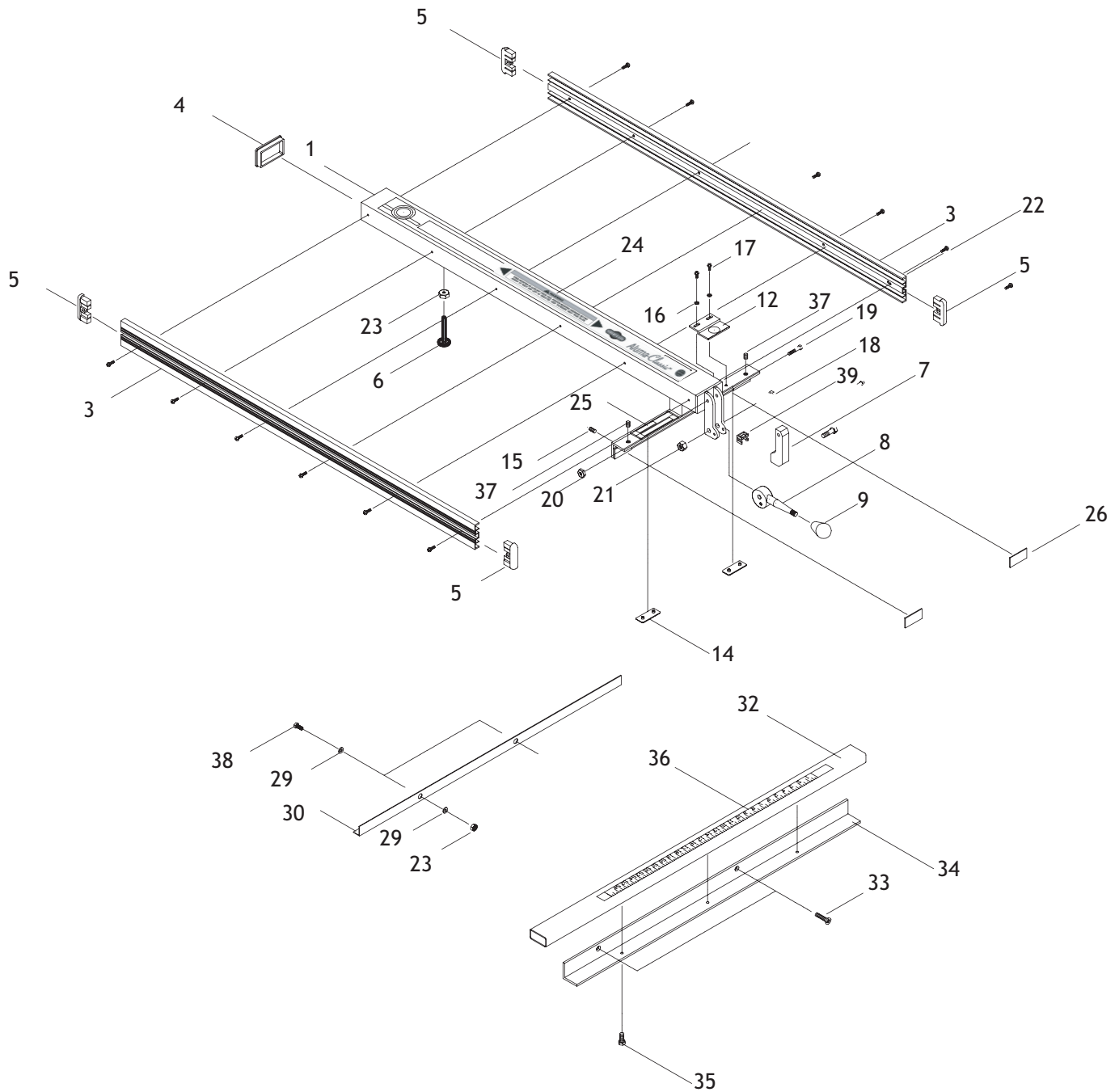

Figure 15. Scale installed on front rail.

W1716 SHOP FOX® Aluma-Classic™ Fence



W1716 SHOP FOX® Aluma-Classic™ Fence

REF	PART #	DESCRIPTION
1	X1716001	FENCE BODY ASSEMBLY
3	X1716003	FENCE SIDEBOARD
4	X1716004	FENCE PLUG
5	X1716005	FENCE SIDEBOARD CAP
6	X1716006	ADJUSTMENT BOLT 5/16"-18
7	X1716007	CLAMP
8	X1716008	HANDLE
9	X1716009	FEMALE KNOB
12	X1716012	CLEAR INDICATOR
14	X1716014	SLIDER 19 X 50 X 2T
15	XPSS05	SETSCREW 5/16"-18 X 1/4"
16	XPW03	FLAT WASHER #10
17	XPS06	PHLP HD SCR 10-24 X 3/8"
18	XPB25	HEX BOLT 3/8"-16 X 1 3/4"
19	PB88	HEX BOLT 1/4"-20 X 1 3/4"
20	XPLN02	LOCK NUT 1/4"-20
21	XPLN01	LOCK NUT 3/8"-16
22	XPS24	PHLP HD SCR 8-32 X 3/8"
23	XPN02	HEX NUT 5/16"-18
24	X1716024	ALUMA-CLASSIC™ LABEL
25	X1716025	WARNING LABEL (SHORT)
26	X1716026	SLIDER 19 X 50 X 1.2T
29	XPW07	FLAT WASHER 5/16"
30	X1716030	REAR RAIL
32	X1716032	FRONT RAIL
33	XPFH25	FLAT HD SCR 5/16"-18 X 1
34	X1716033	FRONT RAIL BRACKET
35	XPB05	HEX BOLT 1/4"-20 X 3/4"
36	X1716036	SCALE 30"
37	XPSS05	SETSCREW 5/16"-18 X 1/4"
38	XPSB03	CAP SCREW 5/16"-18 X 1
39	X1716039	CLAMP PLUG

W1720 SHOP FOX® Aluma-Classic™ Fence

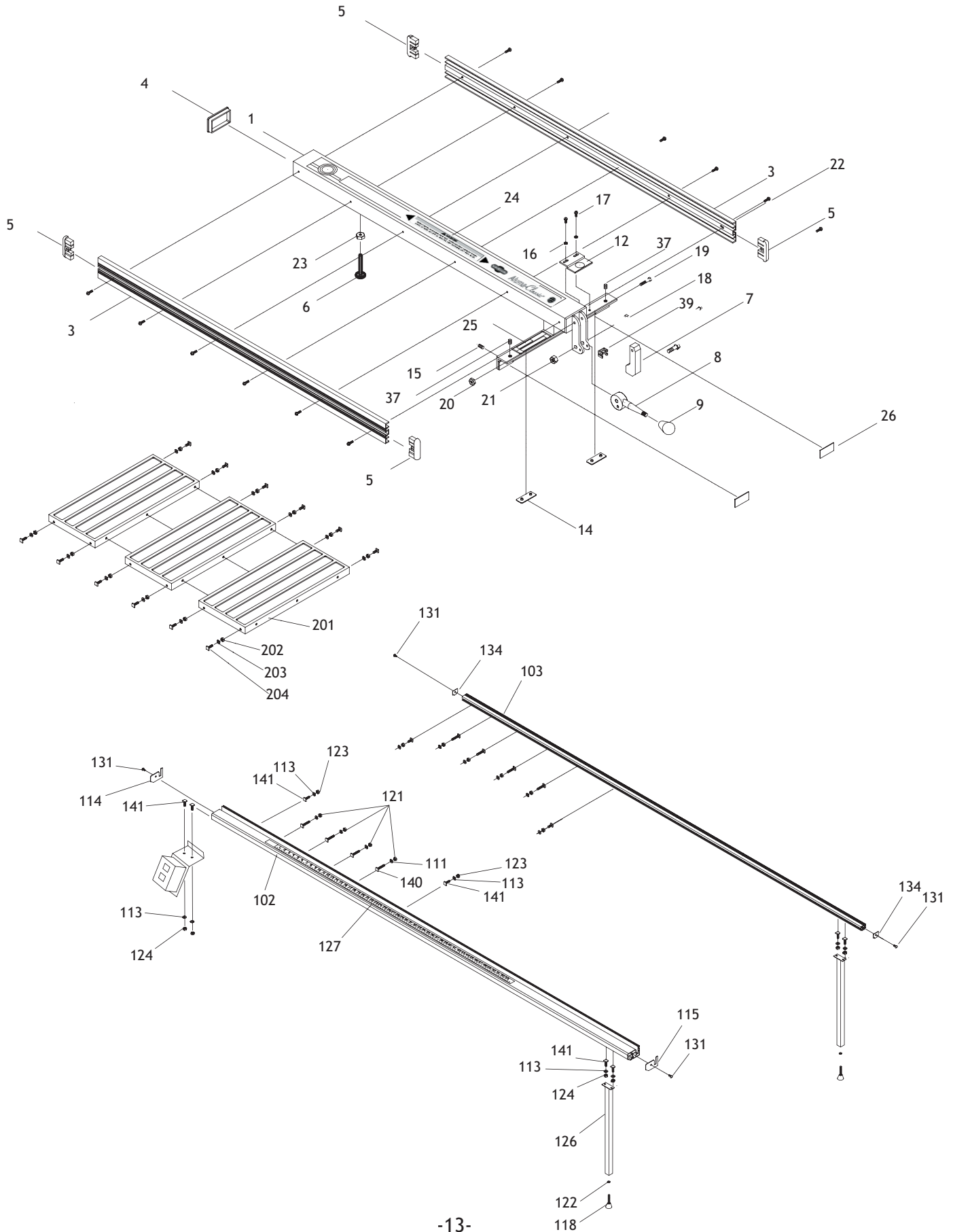



W1720 SHOP FOX® Aluma-Classic™ Fence

REF	PART #	DESCRIPTION
1	X1716001	FENCE BODY ASSEMBLY
3	X1716003	FENCE SIDEBOARD
4	X1716004	FENCE PLUG
5	X1716005	FENCE SIDEBOARD CAP
6	X1716006	ADJUSTMENT BOLT 5/16"-18
7	X1716007	CLAMP
8	X1716008	HANDLE
9	X1716009	FEMALE KNOB
12	X1716012	CLEAR INDICATOR
14	X1716014	SLIDER 19 X 50 X 2T
15	XPSS05	SETSCREW 5/16"-18 X 1/4"
16	XPW03	FLAT WASHER #10
17	XPS06	PHLP HD SCR 10-24 X 3/8"
18	XPB25	HEX BOLT 3/8"-16 X 1 3/4"
19	XPB119	HEX BOLT 1/4"-20 X 1 3/4"
20	XPLN02	LOCK NUT 1/4"-20
21	XPLN01	LOCK NUT 3/8"-16
22	XPS24	PHLP HD SCR 8-32 X 3/8"
24	X1716024	ALUMA-CLASSIC™ LABEL
25	X1716025	WARNING LABEL (SHORT)
26	X1716026	SLIDER 19 X 50 X 1.2T
37	XPSS05	SETSCREW 5/16"-18 X 1/4"

REF	PART #	DESCRIPTION
39	X1716039	CLAMP PLUG
102	X1721002	ALUMINUM FRONT RAIL
103	X1721003	ALUMINUM REAR RAIL
111	XPW03M	FLAT WASHER 6MM
113	XPW07	FLAT WASHER 5/16"
114	X1721014	FRONT RAIL CAP (L)
115	X1721015	FRONT RAIL CAP (R)
118	X1721018	RUBBER FOOT BOLT
121	XPN01M	HEX NUT M6-1
122	XPN08	HEX NUT 3/8"-16
123	XPN02	HEX NUT 5/16"-18
124	XPN02	HEX NUT 5/16"-18
126	X1721026	LEG (LONG)
127	X1721027	LENGTH SCALE 50"
131	XPHTK7	SELF TAP SCREW #8 X 3/8"
134	X1721034	REAR RAIL CAP
140	X1721040	SQUARE BOLT M6-1 X 30
141	X1721041	SQUARE BOLT 5/16"-18 X 3/4"
201	X1722001	METAL WING
202	XPN02	HEX NUT 5/16"-18
203	XPW07	FLAT WASHER 5/16"
204	X1721041	SQUARE BOLT 5/16"-18 X 3/4"

WARRANTY CARD

Name _____
Street _____
City _____ State _____ Zip _____
Phone Number _____ E-Mail _____ FAX _____
MODEL # _____ Serial # _____

The following information is given on a voluntary basis and is strictly confidential.

1. Where did you purchase your **SHOP FOX®** machine? _____
2. How did you first learn about us?
___Advertisement _____Friend
___Mail order Catalog _____Local Store
___World Wide Web Site
___Other _____
3. Which of the following magazines do you subscribe to.
___American Woodworker _____Today's Homeowner
___Cabinetmaker _____WOOD
___Family Handyman _____Wooden Boat
___Fine Homebuilding _____Woodshop News
___Fine Woodworking _____Woodsmith
___Home Handyman _____Woodwork
___Journal of Light Construction _____Woodworker
___Old House Journal _____Woodworker's Journal
___Popular Mechanics _____Workbench
___Popular Science _____American How-To
___Popular Woodworking
___Other _____
4. Which of the following woodworking/remodeling shows do you watch?
___Backyard America _____The New Yankee Workshop
___Home Time _____This Old House
___The American Woodworker _____Woodwright's Shop
___Other _____
5. What is your annual household income?
___\$20,000-\$29,999 _____\$60,000-\$69,999
___\$30,000-\$39,999 _____\$70,000-\$79,999
___\$40,000-\$49,999 _____\$80,000-\$89,999
___\$50,000-\$59,999 _____\$90,000 +
6. What is your age group?
___20-29 _____50-59
___30-39 _____60-69
___40-49 _____70 +
7. How long have you been a woodworker?
___0 - 2 Years _____8 - 20 Years
___2 - 8 Years _____20+ Years
8. How would you rank your woodworking skills?
___Simple _____Advanced
___Intermediate _____Master Craftsman
9. How many **SHOP FOX®** machines do you own? _____
10. What stationary woodworking tools do you own? Check all that apply.
___Air Compressor _____Panel Saw
___Band Saw _____Planner
___Drill Press _____Power Feeder
___Drum Sander _____Radial Arm Saw
___Dust Collector _____Shaper
___Horizontal Boring Machine _____Spindle Sander
___Jointer _____Table Saw
___Lathe _____Vacuum Veneer Press
___Mortiser _____Wide Belt Sander
___Other _____
11. Which benchtop tools do you own? Check all that apply.
___1" x 42" Belt Sander _____6" - 8" Grinder
___5" - 8" Drill Press _____Mini Lathe
___8" Table Saw _____10" - 12" Thickness Planer
___8" - 10" Bandsaw _____Scroll Saw
___Disc/Belt Sander _____Spindle/Belt Sander
___Mini Jointer
___Other _____
12. Which portable/hand held power tools do you own? Check all that apply.
___Belt Sander _____Orbital Sander
___Biscuit Joiner _____Palm Sander
___Circular Saw _____Portable Planer
___Detail Sander _____Saber Saw
___Drill/Driver _____Reciprocating Saw
___Miter Saw _____Router
___Other _____
13. What machines/supplies would you like to see?

14. What new accessories would you like Woodstock International to carry?

15. Do you think your purchase represents good value?
___Yes _____No
16. Would you recommend **SHOP FOX®** products to a friend?
___Yes _____No
17. Comments: _____

CUT ALONG DOTTED LINE

FOLD ALONG DOTTED LINE

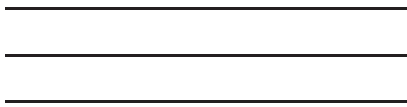

Place
Stamp
Here



WOODSTOCK INTERNATIONAL, INC.
P.O. BOX 2309
BELLINGHAM, WA 98227-2309



FOLD ALONG DOTTED LINE

TAPE ALONG EDGES--PLEASE DO NOT STAPLE

