



MODEL H6189 3/8" INDUSTRIAL AIR RATCHET INSTRUCTION SHEET

⚠ WARNING

	EYE/EAR INJURY HAZARD! Wear safety glasses and hearing protection during use of this tool!
	INJURY HAZARD! Always disconnect tool from air to prevent unexpected operation during service!
	DO NOT EXCEED 120 PSI! Personal injury could occur.



Figure 1. Model H6189

Introduction

- 230 RPM free speed
- 30 ft/lbs maximum torque
- 90 PSI operating pressure
- 5 CFM average air consumption
- 92 dB(A) sound level
- 1/4" Air inlet
- Forward and reverse
- Short, ergonomic profile

Inventory

- A. 1/4" Industrial Air Ratchet..... 1

Operation

Install any 3/8" drive socket onto your air ratchet. Choose from clockwise (R) to tighten, or counterclockwise (L) to loosen by turning the direction control on top of the ratchet. Connect the air ratchet to your regulated air source.

Air ratchet **MUST** have 3-4 drops of air tool oil directly dropped into the air fitting before each use as shown in **Figure 2**.

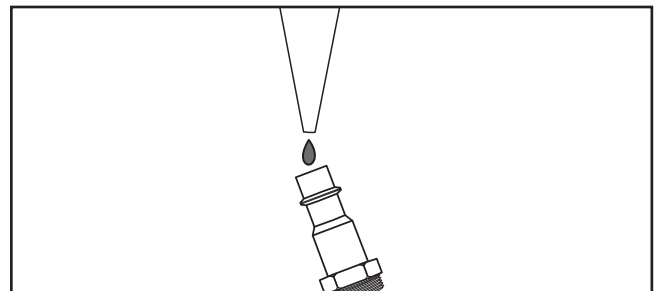

Figure 2. Lubricating directly into air fitting.

If you need help with your new pneumatic tool, call our Tech Support at: (570) 546-9663.

COPYRIGHT © JUNE, 2006 BY GRIZZLY INDUSTRIAL, INC.

WARNING: NO PORTION OF THIS MANUAL MAY BE REPRODUCED IN ANY SHAPE OR FORM WITHOUT THE WRITTEN APPROVAL OF GRIZZLY INDUSTRIAL, INC.

#PC8327 PRINTED IN TAIWAN

H6189 Parts Breakdown and List

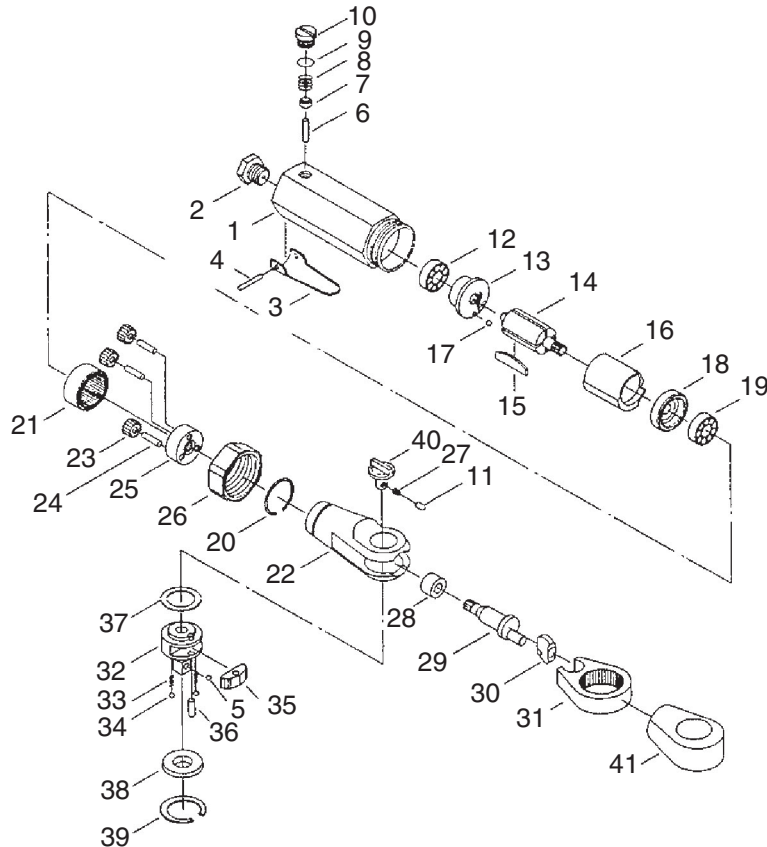

REF	PART #	DESCRIPTION
1	PH6189001	HOUSING
2	PH6189002	AIR INLET
3	PH6189003	THROTTLE LEVER
4	PH6189004	ROLL PIN
5	PH6189005	STEEL BALL
6	PH6189006	VALVE PIN
7	PH6189007	VALVE
8	PH6189008	COMPRESSION SPRING
9	PH6189009	O-RING
10	PH6189010	VALVE PLUG
11	PH6189011	LOCK PIN
12	PH6189012	REAR BEARING
13	PH6189013	REAR PLATE
14	PH6189014	ROTOR
15	PH6189015	ROTOR BLADE
16	PH6189016	CYLINDER
17	PH6189017	CYLINDER PIN
18	PH6189018	FRONT PLATE
19	PH6189019	FRONT BEARING
20	PH6189020	RETAINER RING
21	PH6189021	THREAD RING GEAR

REF	PART #	DESCRIPTION
22	PH6189022	RATCHET HOUSING
23	PH6189023	IDLER GEAR
24	PH6189024	IDLER GEAR PIN
25	PH6189025	INDLER GEAR PLATE
26	PH6189026	CLAMP NUT
27	PH6189027	COMPRESSION SPRING
28	PH6189028	NEEDLE BEARING
29	PH6189029	CRANK SHAFT
30	PH6189030	DRIVE BUSHING
31	PH6189031	RATCHET YOKE
32	PH6189032	RATCHET ANVIL
33	PH6189033	COMPRESSION SPRING
34	PH6189034	STEEL BALL
35	PH6189035	PAWL
36	PH6189036	DOWEL PIN
37	PH6189037	THIN WASHER
38	PH6189038	THRUST WASHER
39	PH6189039	RETAINER RING
40	PH6189040	REVERSE BUTTON
41	PH6189041	RUBBER GRIP