



Model D3393 Elliptical Jig Instruction Sheet

⚠️ WARNING

- Read and understand these instructions! Woodstock International Inc. shall not be responsible for damage or injuries caused by improper use or modification of this machine.
- If you do not understand these instructions or if you have questions, contact Woodstock International Technical Support at (360) 734-3482 before proceeding.

Introduction

The elliptical jig enables the Model W1693 Planer/Moulder to cut up to 6 1/2" wide curved mouldings if they have a radius greater than 7" and a minimum length of 9". The moulding material must be pre-cut to the desired arc and attached to a 3/4" thick template as shown in Figure 1.

Elliptical Jig Assembly

To assemble the jig, do these steps:

1. Lay the contents of the shipping box out to take an inventory of the main components.

Box Contents (Figure 2)	QTY
A. Base Plate with Vise	1
B. Base Plate Support Studs	4
Hex Nuts 3/8-16	8
Flat Washers 3/8"	8
C. Flat Head Screws 1/4-20 x 1/2"	6
D. Wrench 12/14mm	1
E. Hex Wrenches 4 & 6mm	1 Ea
F. Mounting Clamps	2

If any parts appear to be missing, examine the packaging carefully to be sure those parts are not among the packing materials. If any parts are missing, find the part number in the back of this instruction sheet and contact Woodstock International, Inc. at (360) 734-3482 or at tech-support@shopfox.biz.

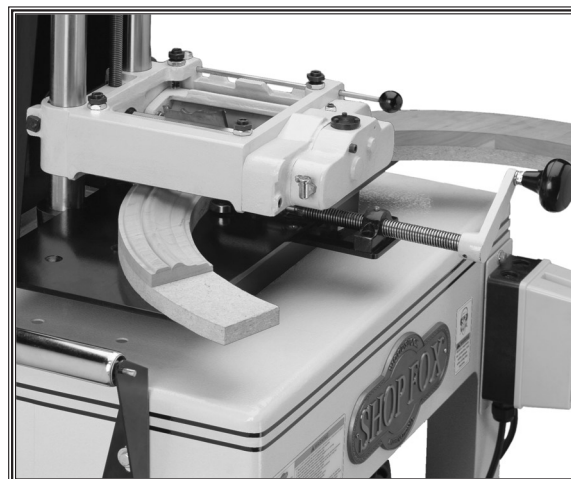

Figure 1. Cutting arched moulding.

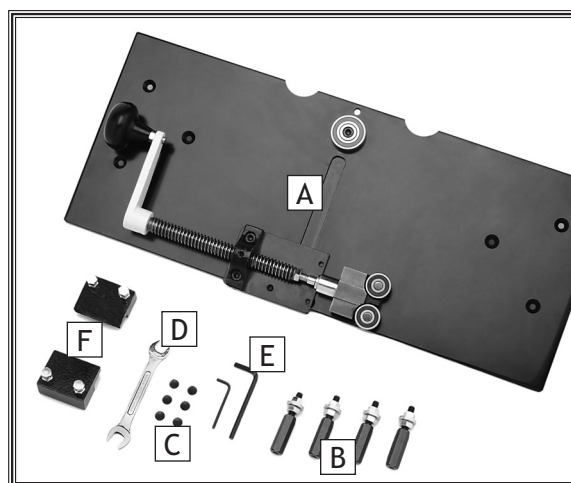

Figure 2. Elliptical jig inventory.

2. Remove the flat head screws securing the vise to the base plate.
 3. Slide the dovetail on the bottom of the vise bearing block (**Figure 3**) into the dovetail groove in the base plate.
 4. Secure the vise to the base plate with the flat head screws removed in **Step 2**.
 5. Remove the plugs from the planer/moulder stand.
 6. Remove a hex nut and a washer from each of the base plate support studs.
 7. Insert the studs as shown in **Figure 4** and loosely thread the nuts and washers removed in **Step 6** onto the studs from under the stand.
 8. Place the base plate onto the planer/moulder table and attach it to the studs with the flat head screws.
- Note:** The studs should be drawn up tight against the bottom of the base plate.
9. Thread the top hex nuts down against the stand and tighten the lower hex nuts up against the stand.
 10. Loosely attach the mounting clamps to the base plate with the remaining flat head screws.
 11. Adjust the flat head screw and the hex bolts in the mounting clamp until the mounting clamp is parallel with the planer/moulder surface (see **Figure 5**).
 12. Tighten the flat head screws to secure the clamps.

Setup

To prepare for cutting mouldings, do these steps:

1. Build the moulding blank to the desired size and curve. Make the blank the exact same width as the moulding blades if the face is profiled, or a maximum of $\frac{1}{8}$ " wider if the edges are trimmed by the knives.
2. Build a template out of $\frac{3}{4}$ " MDF that is the exact width and curve as your moulding. Make the template a minimum of $6\frac{1}{2}$ " longer than the moulding. This template will guide the moulding through the planer/moulder.

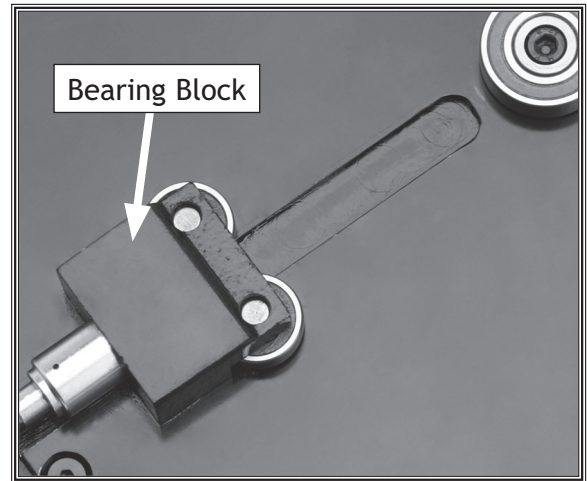

Figure 3. Support assembly bearing block.

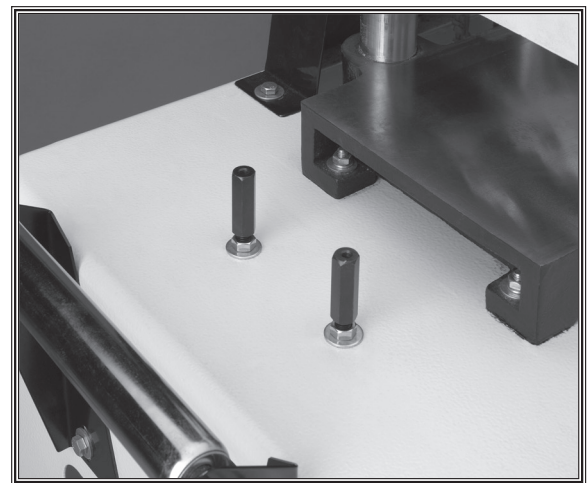

Figure 4. Base plate support studs.

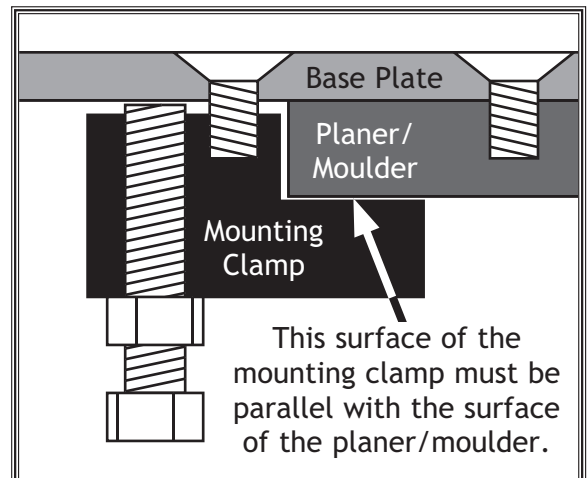

Figure 5. Mounting clamp attachment.

⚠ WARNING

Keep all mounting screws clear of the blade path to prevent serious personal injury and damage to the planer/moulder (see Figure 6).

3. Layout the mounting holes on the template as shown in Figure 6.
 - Place the holes in the template so the moulding blank will mount with 4" of the template showing in front of the mounting blank and 1½" behind.
 - Make sure the holes are located so that the screws will not be hit when moulding.
 - If you are attaching multiple sections to the same template, make sure that there are mounting holes for each section.
4. Drill and countersink the mounting holes.
5. Mount the moulding blank to the template with wood screws. Make sure the screws are short enough so they will not be hit by the moulding blades.

Operations

To cut curved mouldings, do these steps:

1. Disconnect power to the planer/moulder.
2. Place the template with the moulding blank against the base plate bearing and tighten the vise bearings against the template. After the initial contact, turn the crank 1 to 1¼ turns to apply adequate pressure.
3. Make sure the edge of the moulding blank aligns with the edge of the blades. If the moulding blank does not align with the blades, remove the screws securing the base plate to the support studs (**Figure 7**) and adjust the base plate to align the moulding blank. Tighten the mounting clamps securing the base plate to the planer/moulder before moulding.
4. Adjust the cutterhead height as instructed in the planer/moulder manual.
5. Turn the planer/moulder **ON** and feed the template between the bearings on the base plate and into the machine. **Note:** *The template will need to be supported by a roller stand or a person as it is fed through the planer/moulder.*

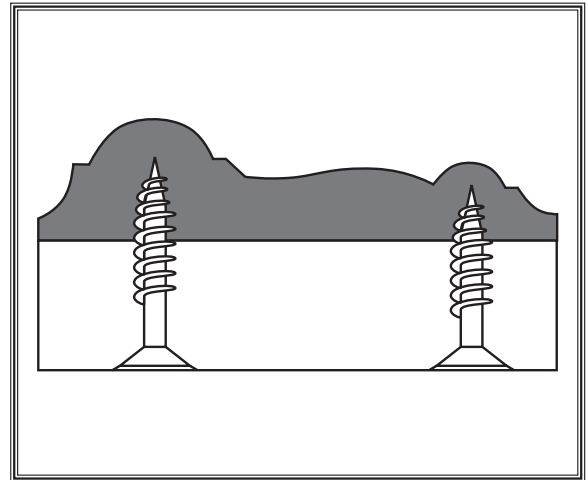

Figure 6. Attaching the moulding blank.

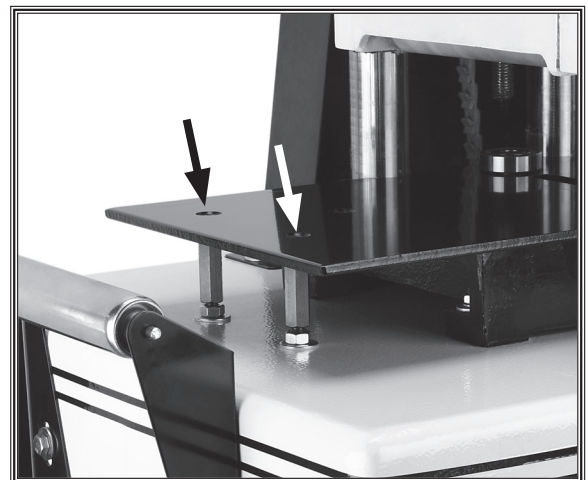
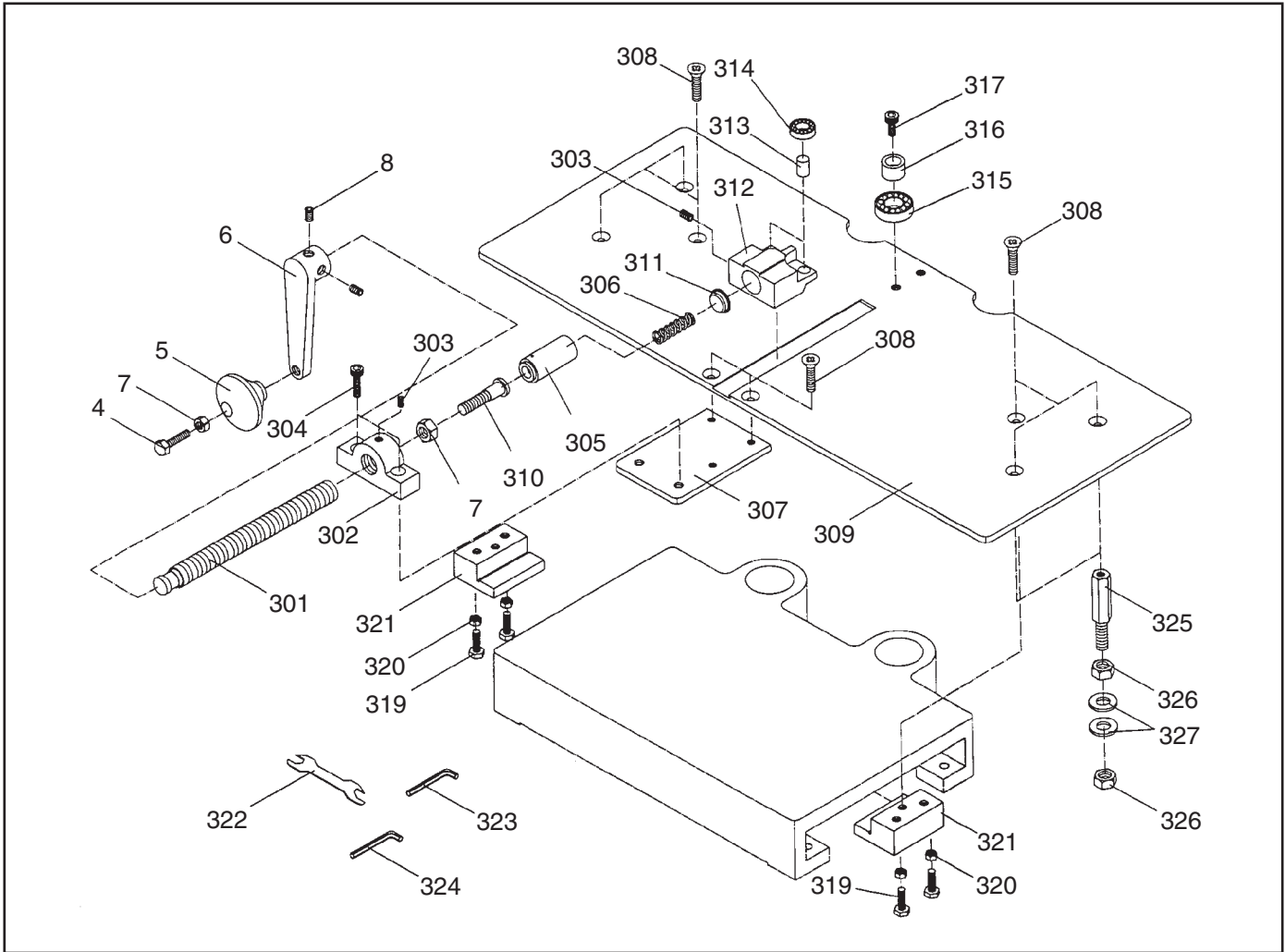

Figure 7. Remove screws to adjust the base plate.



REF PART #	DESCRIPTION
4	XPB25 HEX BOLT 3/8-16 X 1 3/4
5	X1693005 HANDLE KNOB
6	X1693006 CRANK HANDLE
7	XPNO8 HEX NUT 3/8-16
8	XPSS11 SET SCREW 1/4-20 X 1/4
301	XD3393301 ACME SCREW
302	XD3393302 ACME NUT
303	XPSS03 SET SCREW 1/4-20 X 3/8
304	XPSB30 CAP SCREW 5/16-18 X 1/2
305	XD3393305 BUSHING
306	XD3393306 COMPRESSION SPRING
307	XD3393307 EXTENSION PLATE
308	XPFH03 FLAT HD SCR 1/4-20 X 1/2
309	XD3393309 BASE PLATE
310	XD3393310 SPECIAL BOLT 3/8"
311	XD3393311 PLUNGER

REF PART #	DESCRIPTION
312	XD3393312 BEARING BLOCK
313	XD3393313 SPACER
314	XP6200 BALL BEARING 6200
315	XP6004 BALL BEARING 6004ZZ
316	XD3393316 SPACER
317	XPSB138M CAP SCREW 5/16-18 X 3/8
319	XPB11 HEX BOLT 5/16-18 X 1-1/2
320	XPNO2 HEX NUT 5/16-18
321	XD3393321 MOUNTING CLAMP
322	XPWR1214 COMBO WRENCH 12 X 14
323	XPAW04M HEX WRENCH 4MM
324	XPAW06M HEX WRENCH 6MM
325	XD3393325 STUD
326	XPNO8 HEX NUT 3/8-16
327	XLPLW04 LOCK WASHER 3/8

Phone: 1-360-734-3482 • On-Line Technical Support: tech-support@shopfox.biz

COPYRIGHT © JUNE, 2005 BY WOODSTOCK INTERNATIONAL, INC.

WARNING: NO PORTION OF THIS INSTRUCTION SHEET MAY BE REPRODUCED IN ANY SHAPE OR FORM WITHOUT THE WRITTEN APPROVAL OF WOODSTOCK INTERNATIONAL, INC.

#7265EW

Printed in Taiwan