

Grizzly *Industrial, Inc.*®

MODEL H8180/H8181 BASS GUITAR KIT OWNER'S MANUAL

H8180



H8181



COPYRIGHT © NOVEMBER, 2007 BY GRIZZLY INDUSTRIAL, INC.
WARNING: NO PORTION OF THIS MANUAL MAY BE REPRODUCED IN ANY SHAPE
OR FORM WITHOUT THE WRITTEN APPROVAL OF GRIZZLY INDUSTRIAL, INC.

#BL10143 PRINTED IN KOREA



WARNING!

Some dust created by power sanding, sawing, grinding, drilling, and other construction activities contains chemicals known to the State of California to cause cancer, birth defects or other reproductive harm. Some examples of these chemicals are:

- **Lead from lead-based paints.**
- **Crystalline silica from bricks, cement and other masonry products.**
- **Arsenic and chromium from chemically-treated lumber.**

Your risk from these exposures varies, depending on how often you do this type of work. To reduce your exposure to these chemicals: Work in a well ventilated area, and work with approved safety equipment, such as those dust masks that are specially designed to filter out microscopic particles.

Table of Contents

SECTION 1: SAFETY	2
SECTION 2: INTRODUCTION	3
Foreword	3
Contact Info	3
SECTION 3: PARTS INVENTORY	4
Inventory.....	4
Supplies/Tools	5
Identification	6
SECTION 4: ASSEMBLY	7
Shaping Headstock	7
Sanding Body	8
Sanding Neck	8
Finishing Neck.....	9
Finishing Body.....	9
Mounting Neck	10
Positioning Bridge	12
Mounting Tuners	13
Wiring Pickups & Output Jack.....	14
Installing Bridge & Pickups	15
Strap Buttons	16
Installing Nut	16
Truss Rod Cover	17
Winding Strings	17
SECTION 5: SETUP	19
General.....	19
Neck Adjustment	19
String Height	20
Pickup Height	21
Tuning	22
Setting Intonation	22
SECTION 6: REFERENCE INFO	23
Accessories	23
Electrical Components	27
Wiring Diagram	28

SECTION 1: SAFETY

WARNING

Always wear safety glasses or goggles when operating equipment. Everyday glasses or reading glasses are not safety glasses. Be certain the safety glasses you wear meet the appropriate standards of the American National Standards Institute (ANSI).

Because there are various ways to cut and join wood, you can make substitutions for the methods stated in this plan. We try to suggest the easiest methods possible. However, only you know your skills with each piece of machinery. Never compromise your safety by using a cutting method with which you are not comfortable. Instead, find an alternative approach that will yield the same result.

WARNING

These instructions assume that you are intimately familiar with the safe operation and use of woodworking machinery and woodworking tools, and understand the techniques used to build this project. If you do not qualify for both of these criteria, **STOP building this project for your own safety.** Read and understand the owners manual for the machinery you intend to use, take a woodworking class or visit your local library for more information. Woodworking machinery and tools are inherently dangerous because they use sharp edges that can and will cause serious personal injury including amputation and death. Do not underestimate the ability of these tools and machinery to cause injury. Never operate any tool without all guards in place and always wear approved safety glasses. For your own safety, please heed this warning.

SECTION 2: INTRODUCTION

Foreword

We are proud to offer the Model H8180/H8181 Bass Guitar Kit. This kit is a part of a growing Grizzly family of fine woodworking products. When assembled according to the guidelines set forth in this manual, you can expect years of enjoyment from your guitar.

The drawings and photographs illustrated in this manual represent the Model H8180/H8181 when the manual was prepared. However, owing to Grizzly's policy of continuous improvement, changes may be made at any time with no obligation on the part of Grizzly.

For your convenience, we always keep current Grizzly manuals available on our website at **www.grizzly.com**. Any updates to your kit will be reflected in these manuals as soon as they are complete. Visit our site often to check for the latest updates to this manual!

Contact Info

If you have any comments regarding this manual, please write to us at the address below:

Grizzly Industrial, Inc.
c/o Technical Documentation Manager
P.O. Box 2069
Bellingham, WA 98227-2069
Email: manuals@grizzly.com

We stand behind our products. If you have any service questions or parts requests, please call or write us at the location listed below.

Grizzly Industrial, Inc.
1203 Lycoming Mall Circle
Muncy, PA 17756
Phone: (570) 546-9663
Fax: (800) 438-5901
E-Mail: techsupport@grizzly.com
Web Site: <http://www.grizzly.com>



SECTION 3: PARTS INVENTORY

Inventory

REF	PART#	DESCRIPTION	QTY
1	PH8180001	Bass Guitar Body (H8180)	1
	PH8181001	Bass Guitar Body (H8181)	1
2	PH8180002	Neck	1
3	PH8180003	Silver Neckplate (H8180)	1
	PH8181003	Gold Neckplate (H8181)	1
4	PH8180004	Silver Tuning Machine (H8180)	6
	PH8181004	Gold Tuning Machine (H8181)	6
5	PH8180005	Wiring Harness	1
6	PH8180006	Silver Bridge (H8180)	1
	PH8181006	Gold Bridge (H8181)	1
7	PH8180007	Pickup	2
8	PH8180008	String	4
9	PH8180009	Control Cover Plate	1
10	PH8180010	Silver Output Jack (H8180)	1
	PH8181010	Gold Output Jack (H8181)	1
11	PH8180011	Silver Strap Button (H8180)	2
	PH8181011	Gold Strap Button (H8181)	2
12	PH8180012	Compression Spring	4
13	PH8180013	String Nut	1
14	PH8180014	Truss Rod Cover	1
15	PH8180015	Silver Control Knob (H8180)	3
	PH8181015	Gold Control Knob (H8181)	3
16	PH8180016	Silver Hex Nut Bushing 1/2" (H8180)	4
	PH8181016	Gold Hex Nut Bushing 1/2" (H8181)	4
17	PH8180017	Silver Flat Washer 1/2" (H8180)	4
	PH8181017	Gold Flat Washer 1/2" (H8181)	4
18	PAW01.5M	Hex Wrench 1.5mm	1
19	PAW04M	Hex Wrench 4mm	1
20	PH8180020	Silver Screw #2 x 3/8" (H8180)	2
	PH8181020	Gold Screw #2 x 3/8" (H8181)	2
21	PH8180021	Silver Screw #2 x 1/2" (H8180)	6
	PH8181021	Gold Screw #2 x 1/2" (H8181)	6
22	PH8180022	Silver Screw #2 x 1-3/8 (H8180)	4
	PH8181022	Gold Screw #2 x 1-3/8 (H8181)	4
23	PH8180023	Silver Screw #4 x 1/2" (H8180)	6
	PH8181023	Gold Screw #4 x 1/2" (H8181)	6
24	PH8180024	Silver Screw #4 x 1" (H8180)	8
	PH8181024	Gold Screw #4 x 1" (H8181)	8
25	PH8180025	Silver Screw #10 x 1-3/4" (H8180)	4
	PH8181025	Gold Screw #10 x 1-3/4" (H8181)	4

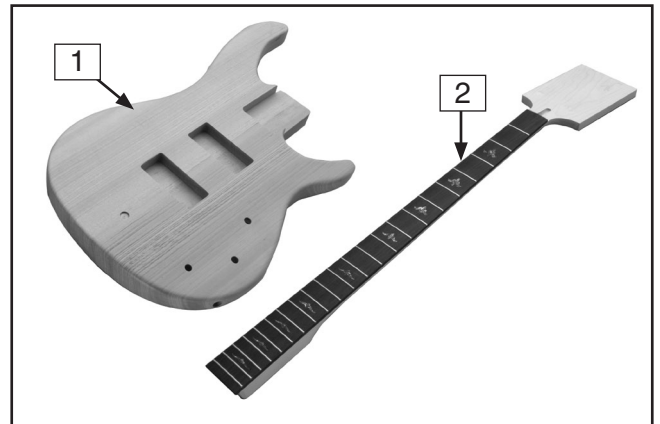

Figure 1. Boxed components.

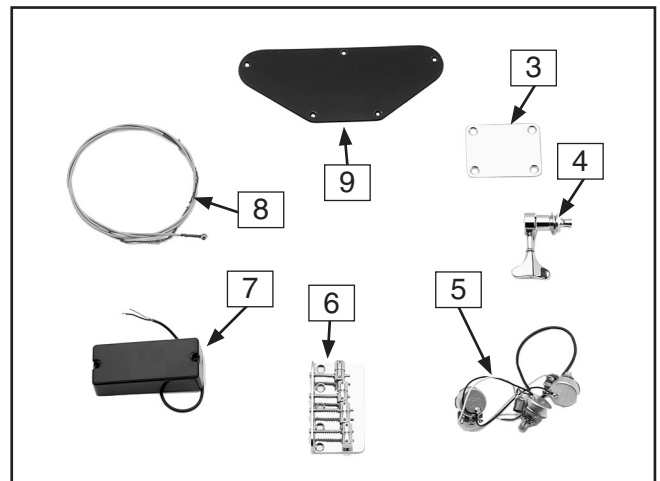

Figure 2. Guitar parts.

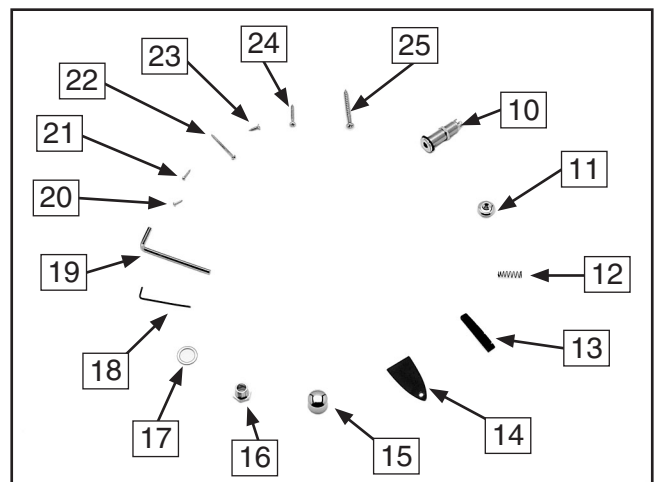

Figure 3. More guitar parts.



Supplies/Tools

Most wood components in this kit are fully machined at the factory and are ready for assembly. A small amount of sanding and finishing is needed to complete your guitar.

Recommended Tools & Supplies:

- Sharp Pencil
- Carbon Paper
- Drill Press
- Drill Bits: $\frac{1}{16}$ ", $\frac{3}{32}$ ", $\frac{9}{64}$ ", $\frac{5}{32}$ ", $\frac{5}{16}$ ", $\frac{11}{32}$ ", $\frac{1}{4}$ "
- Electric/Cordless Drill
- Depth Stop
- NIOSH Approved Respirator
- ANSI Approved Safety Glasses
- Aluminum-Oxide Sandpaper #150, #220 and #320 Grit
- Wet and Dry Sandpaper #400, #600, and #1000 Grit
- Flexible Sanding Block
- Wood Glue
- Chisel or Razor Blade
- Phillips Screwdriver #1, #2
- $\frac{1}{4}$ " Steel Rod or a Coat Hanger

- Masking Tape
- Bandsaw with $\frac{1}{4}$ " Blade or Coping Saw
- Tack Cloth or Soft Cloth
- Sanding Sealer
- Assorted Wood Files
- Buffing Compounds
- Oil Wood Finish
- Soldering Iron and Solder
- Peghead Reamer or a Round Rasp File
- Tweezers, Pliers, Wire Cutters
- C-Clamps
- Temporary Wood Handle:
Approximately 1" x 2" x 16"
- Guitar Capo
- Feeler Gauge Set
- Spray Primer and Finish (See Note Below)
- 18" Metal Straightedge ($\frac{1}{32}$ " Resolution)
- 36" Metal Straightedge
- Steel Ruler ($\frac{1}{64}$ " Resolution)
- Wood Dowel
- Wood Blocks: 4" x 4" x 12" (2)

Note: Use the same type of paint for primer and finish—either enamel or lacquer base. Do not use different base paints for priming or finishing or your results may not be desirable.



Identification

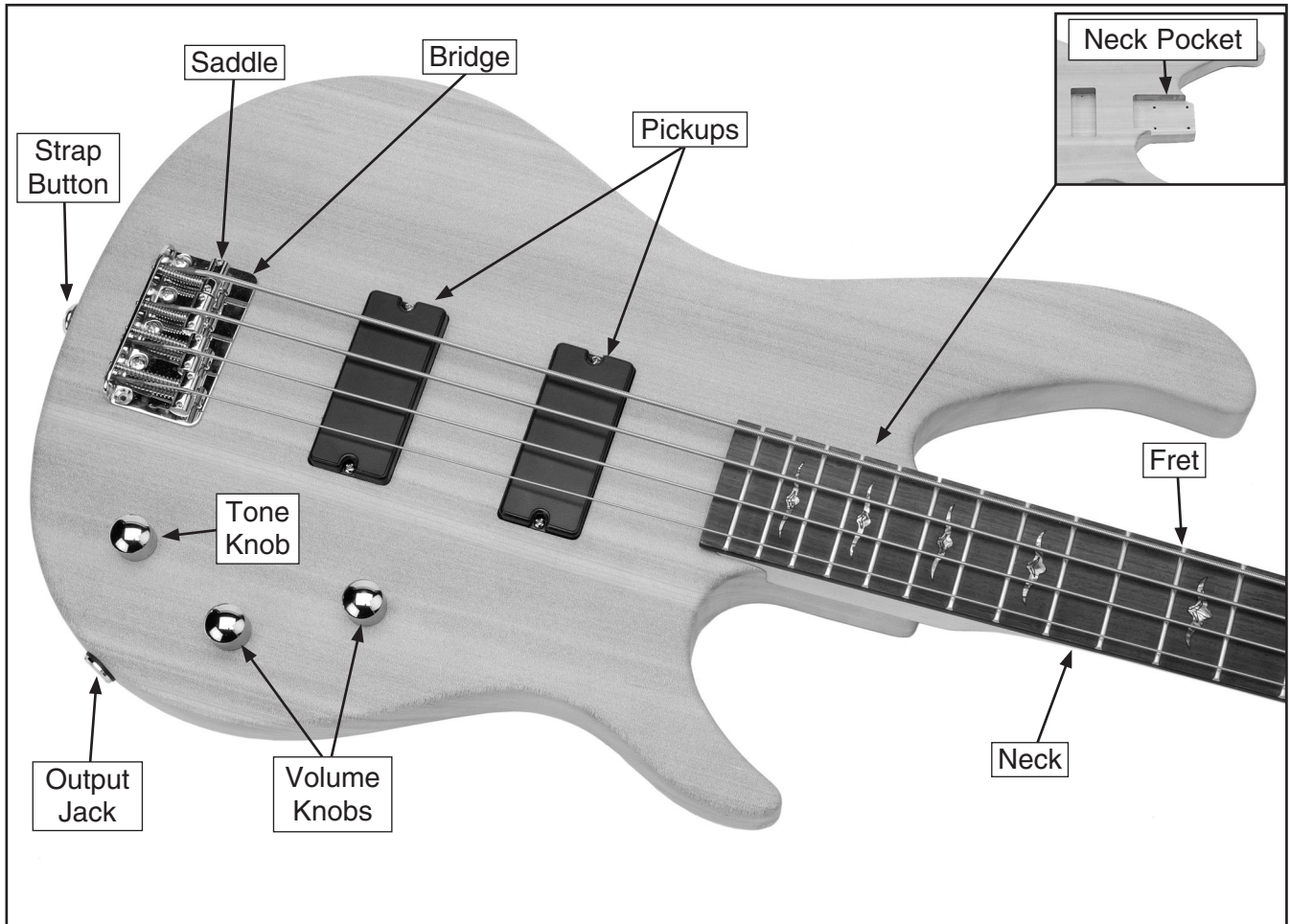

Figure 4. Model H8180/H8181 controls.

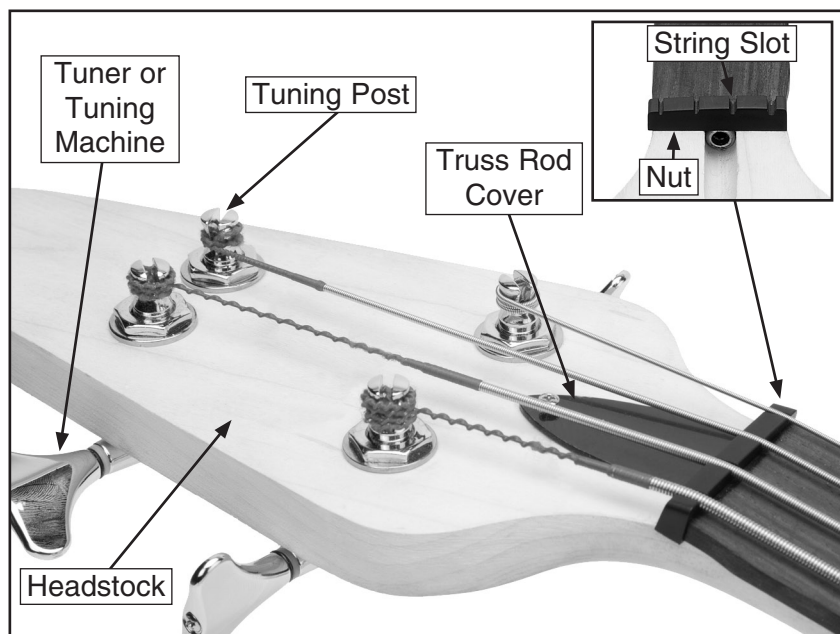

Figure 5. Model H8180/H8181 headstock features.



SECTION 4: ASSEMBLY

Shaping Headstock

The headstock for these models comes unfinished so you can cut it to your own design. These instructions will guide you through designing the shape of the headstock and placing pegholes.

Components Needed	Qty
Guitar Neck	1

Tools Needed

Sharp Pencil	1
Paper or Carbon Paper	Various
Bandsaw with a 1/4" Blade or a Coping Saw	1
Round Rasp Files.....	Assorted
Woodworking Files.....	Assorted
Drill Press with 1/2" Drill Bit	1

To shape the headstock:

1. Trace the headstock on a piece of paper. Test various ideas for headstock shapes on paper before cutting into the headstock.
2. Layout pegholes for the tuners. Space the centers of the pegholes far enough apart so the tuners will not interfere with each other when turned and are a minimum of 3/4" from the edge of the headstock.
3. Draw the path of the strings onto the test paper to ensure that the strings do not interfere with each other as shown in **Figure 6**.

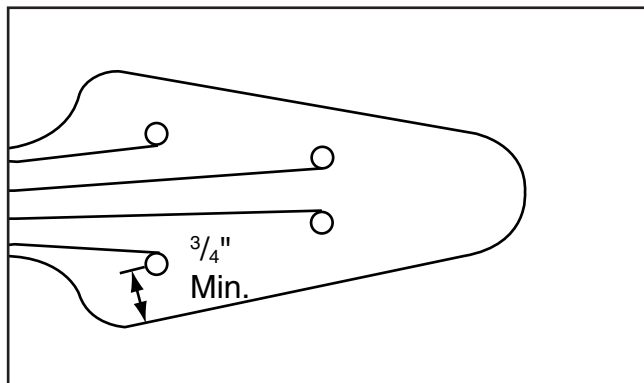

Figure 6. Example of string paths and peghole locations.

Note: To determine the string slot (**Figure 5**) locations, you can place the nut on the drawing and mark the slots. If the strings cross the nut at a sharp angle, this increases friction and makes tuning difficult. It also increases the risk of the strings pulling out of the nut slots.

4. Redraw your final headstock shape onto the headstock with a pencil or with carbon paper.
5. Cut the headstock out with a bandsaw or coping saw. Be sure to cut only to the outside edge of your pencil line.

Note: To cut sharp corners, cut several slots perpendicular to the corner, then cut out the small pieces. This will reduce binding on the blade.

6. Carefully hand file and sand the headstock to finalize the shape.
7. Mark the pegholes onto the headstock.
8. Using a 1/2" bit, drill a hole through the top of the headstock for each tuner shaft, making sure each hole is perpendicular to the headstock surface, as shown in **Figure 7**.



Figure 7. Drilling the pegholes.

9. Carefully use a round rasp to widen the pegholes enough so the tuner shafts fit snugly in the pegholes.



Sanding Body

The guitar body has been sanded at the factory, but it is up to you to do the final sanding before the finish is applied. To get a good finish, the body should be sanded with a series of sandpaper grits up to #320 grit.

Components and Hardware Needed:	Qty
Guitar Body	1

To sand the guitar body:

1. **Wear a NIOSH-approved respirator and ANSI-approved safety glasses when sanding wood!**
2. Use a flexible sanding block with #150 grit aluminum-oxide sandpaper to sand the guitar body until there is a consistent scratch pattern on the entire surface.

Note: *DO NOT round over the neck pocket or the body cavities.*

When hand sanding, always sand in the same direction as the wood grain.

3. Resand the entire guitar body with #220 grit sandpaper and lightly round over the outside edges of the body.
4. Wipe the guitar body with a damp cloth to “raise” the wood grain.
5. Wait until the wood is dry and resand the entire body with #220 grit sandpaper to sand the “raised” grain smooth.

6. Repeat **Step 4 & 5.**

Note: *If you want to stain your guitar, the stain should be applied now before continuing with the next step. Stains cannot be applied to the guitar body after the sanding sealer is applied.*

7. Apply a primer if you plan to paint the guitar a solid color. Apply a coat of sanding sealer if you stained the guitar. Use the sealer or primer according to the manufacturer's instructions.

Note: *Make sure the primer or sealer you use is compatible with your finish.*

8. When the sanding sealer or primer is dry, use #320 grit sandpaper for final sanding. **DO NOT** sand through to bare wood.

Sanding Neck

Like the guitar body, the guitar neck has been rough sanded at the factory. Final sanding should be done as described in the previous sub-section **Sanding Body**. Consider applying inlays or additional design work on the fretboard and headstock before final sanding.

Note: *If you are considering inlays or other design work, take time to test your designs in scrap wood before performing the work on the instrument.*

The fretboard requires no sanding. Sanding the fretboard will affect the playability of the guitar and could lead to irreparable damage.



Finishing Neck

Some of the finishing options include stains, lacquers, varnishes and oil finishes. Traditionally, this style of guitar has a clear finish on the neck. Depending on the type, finishes can be applied with a spray gun, brush, rag, or a spray can. Finish materials and books on finishing instruments can be ordered through Grizzly Industrial or numerous luthier supply catalogs.

Components and Hardware Needed: Qty
Guitar Neck 1

To finish the guitar neck:

1. Mask off the surface of the fretboard. Carefully press all the masking tape edges securely to the fretboard. The finish coat can seep under these edges, especially near corners, uneven edges, and places where the frets meet the fingerboard.
2. Make an "S" shaped hook out of 1/4" steel rod or a coat hanger that has been folded in half.
3. Wipe the entire neck with a tack cloth to remove any dust.
4. Thread the hook through an upper peghole and hang the neck in the finishing room.

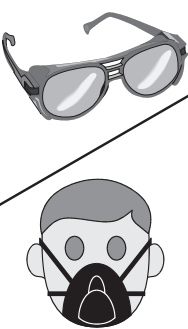
	<p>!WARNING Most finishes are hazardous to your health. Wear a NIOSH/OSHA approved respirator with particulate and gas/vapor filters, safety glasses, rubber gloves, and work in a well ventilated area when finishing.</p>
---	--

5. Apply the finish according to **Finishing Body, Steps 5–10**.
6. Before wet sanding, remove the masking tape from the fretboard and carefully scrape any excess finish off the fretboard with a razor blade or chisel held perpendicular to the surface, as shown in **Figure 8**.

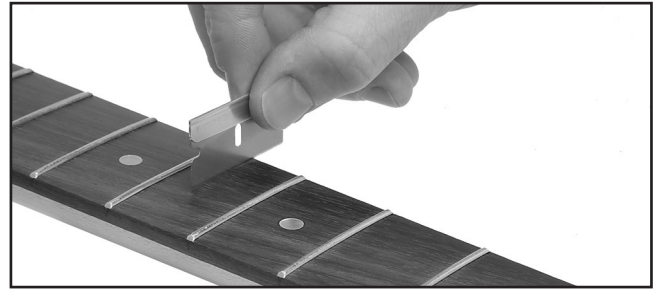

Figure 8. Scraping the fretboard.

7. Let the wood dry naturally and completely.
8. Use a clean rag to wipe wood finishing oil on the dried surface of the fretboard.

Finishing Body

This guitar looks incredible with a clear finish that highlights the wood grain patterns. The surface can be stained prior to finishing or a transparent pigment can be added to the finish. These instructions guide you through a very basic finishing process. Books describing different guitar finishing techniques are available through luthier supply catalogs, or through your local library. Clear finish materials and books on finishing can be ordered through Grizzly Industrial. Finishing a guitar is a difficult task. If you are unsure of your skills, do your research, practice on scrap wood, or take it to a professional.

Components and Hardware Needed: Qty
Guitar Body 1

To finish the guitar body:

1. Mask off the neck pocket (**Figure 4**). Press the masking tape tight against the edges of the pocket so the finish does not seep under the tape.
2. Screw through the neck pocket screw holes into a long piece of wood to use for a handle during spraying. Drill a hole in the end of this temporary handle for hanging from a hook.
3. Wipe the entire guitar body with a tack cloth to remove all dust.
4. Thread the hook through the temporary handle and hang the body in the finish room.



Mounting Neck

5. Apply several thin coats of the finish, following the manufacturer's instructions. Multiple thin coats usually produce a better quality finish than one heavy coat.
6. Sand the entire body with #400 grit wet and dry sandpaper after at least three coats of finish have been applied. DO NOT sand through the finish—be careful on the edges.
7. Apply more finish, sanding between coats, until the finish is the desired thickness.

Note: *If finishing with a solid color, you may wish to apply several coats of a clear finish over the top, sanding between coats, to add depth to the finish.*

8. When the final coat has dried at least a week, preferably a month, remove the temporary handle and masking.
9. Wet sand the finish using #600 grit wet and dry sandpaper using a sanding block, followed with #1000 grit wet and dry sandpaper.
10. Buff the finish by hand or with a buffer, starting with a medium polish and working up to a high gloss polish.

Note: *If using a buffing machine, be careful to avoid going through the finish, especially on the edges.*

NOTICE

Dust particles suspended in the air will settle on wet finishes, causing less than satisfactory results. To avoid this problem:

- Leave the finishing room undisturbed for 24 hours before applying the finish.
- Avoid making unnecessary movements when entering the finish room.
- Apply the finish to the desired parts and immediately leave the room.
- DO NOT return to the room until the specified drying time has elapsed.

Components and Hardware Needed:	Qty
Guitar Body	1
Neck	1
Silver Neckplate	1
Screws #10 x 1 ³ / ₄ "	4

Unless otherwise indicated, we strongly recommend using a drill press for the majority of drilling to obtain the most precise results. However, an electric/cordless drill fitted with a depth stop or a drill stand can be used if you do not have a drill press.

We recommend using a hollow punch (see **Page 23, Accessories**) to carve out holes in the finish before drilling any holes. Also, a router pad can help reduce scratches in the finish.

To mount the neck to the guitar body:

1. Insert the neck into the neck pocket, and check to make sure the neck and body are flush as shown in **Figure 9**.

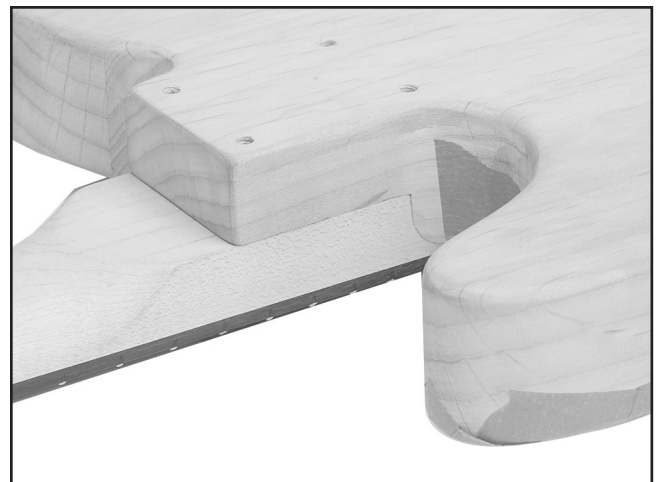

Figure 9. Making neck and body flush.

2. Clamp the neck and body together.
3. Set the guitar facedown on top of two 4x4's or two 2x4's (cut to 12") for support.



4. Insert a $\frac{3}{16}$ " drill bit into each neck hole (**Figure 10**). While pressing down slightly, twist the drill bit by hand to make pilot holes in the neck.



Figure 10. Example of making a pilot hole in the neck.

5. Unclamp the neck from the body.

To determine neck mounting hole depth:

1. Secure a $\frac{9}{64}$ " drill bit in the drill press chuck, raise the table, and set the neck and fretboard down on top of a clean piece of scrap wood on the table.
2. Set the drill press depth stop so the tip of the bit will ONLY drive half way through the neck.

Note: Correctly set the depth stop or the bit may drill through the fretboard!

Another way to determine neck mounting hole depth (Optional):

1. Insert the neck into the neck pocket.
2. Place the neckplate on top of the body so a mounting hole protrudes beyond the body and neck (see **Figure 11**).
3. Insert a #10 x $1\frac{3}{4}$ " screw through the plate so it hangs down to the side of the neck and body.
4. Gently mark the screw tip depth with a pencil.

Note: You may want to cover the screw tip marking location with masking tape to avoid scratching the finish.

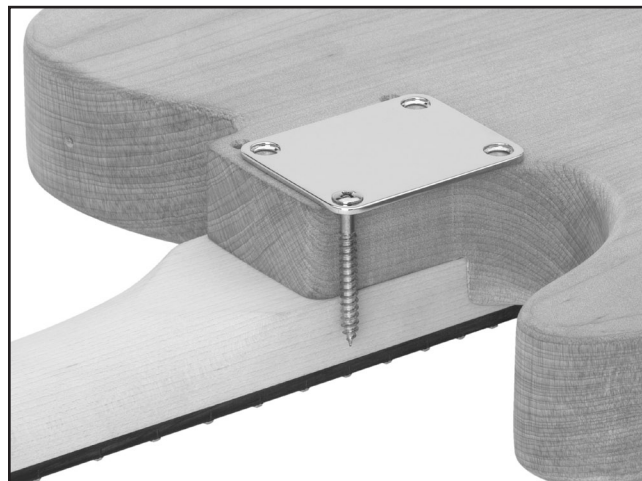

Figure 11. Example of using screw tip depth to set depth stop.

5. Set the neck fretboard face down on the drill press table, and set the depth stop to the mark from **Step 4**.

To drill mounting holes in the neck:

1. Lower a $\frac{9}{64}$ " drill bit over the center of the pilot holes and drill the holes to the correct depth.

To mount the neck to the body:

1. Insert the neck into the neck pocket, and place the neckplate on the body.

Note: Do not glue the neck to the body.

2. Align the mounting holes in the neck, body, and neckplate.
3. Fasten the four #10 x $1\frac{3}{4}$ " screws, but do not final tighten them (**Figure 12**).

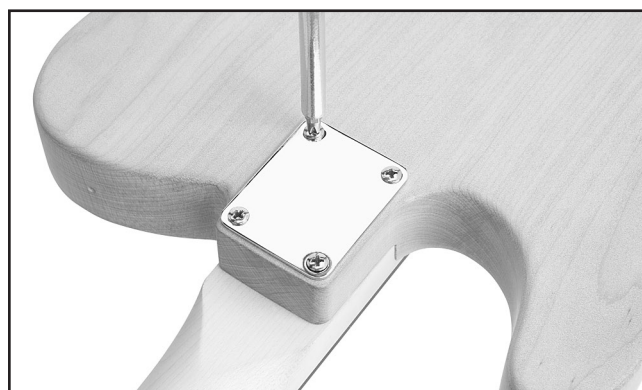

Figure 12. Example of fastening neck to body.



Positioning Bridge

The following steps require you to mark the guitar body. To avoid damaging the finish, place masking tape on the guitar body and gently mark the tape.

Components and Hardware Needed:	Qty
Guitar Body and Neck (Assembled).....	1
Bridge	1

To position the bridge:

1. Place a 36" long straightedge over the center of the fretboard inlays and over the body, so it aligns with the strap button hole, then mark the center line on the guitar body (**Figure 13**).

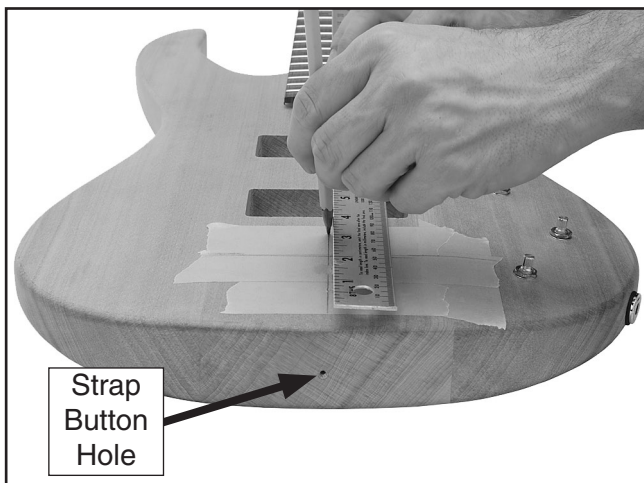

Figure 13. Marking center line.

—If the strap button hole is not pre-drilled, or you do not want to use the strap button hole as a center line marker, place a ruler across the body at several locations and mark the center line.

2. Using the straightedge, measure 34" from the fretboard side of the nut slot (**Figure 14**) along the center line to the bridge point (**Figure 15**), and mark this location on the guitar.

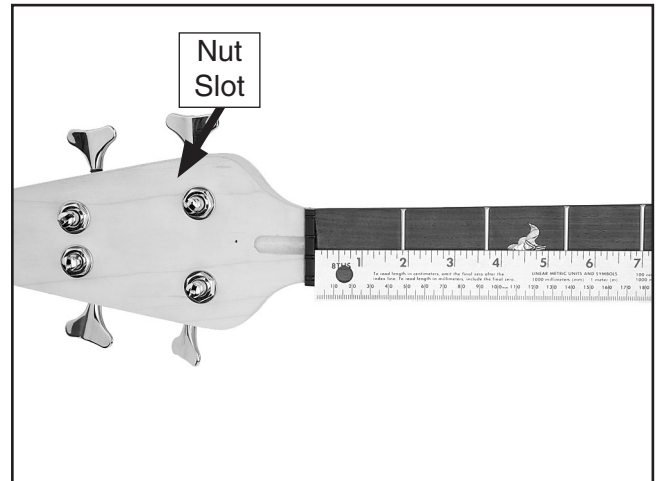

Figure 14. Example of measuring 34" from nut along center line.

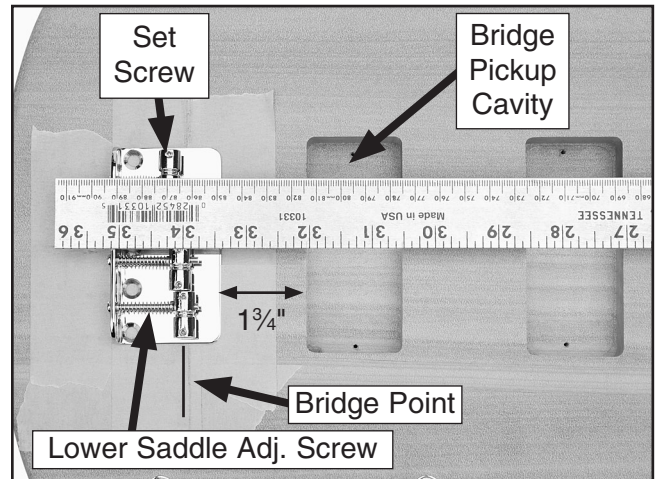

Figure 15. Bridge point, and lower G string saddle adjustment screw.

3. Place the bridge on the body so it is approximately $1\frac{3}{4}$ " from the bridge pickup cavity and align it with the center line, as shown in **Figure 15**.
4. Using a Phillips head screwdriver, turn the G string saddle adjustment screw so the set screws shown in **Figure 15** are centered over the bridge point.
5. Using a Phillips head screwdriver, turn the lower saddle adjustment screw so the set screws shown in **Figure 15** are centered over the bridge point.
6. Mark the bridge mounting holes.
7. Using a $\frac{3}{32}$ " bit, drill the five bridge mounting holes $\frac{7}{8}$ " deep.



Mounting Tuners

Components and Hardware Needed:	Qty
Neck	1
Tuners.....	4
Screws #2 x 1/2	4
Hex Nut Bushings 1/2".....	4
Flat Washers 1/2"	4

To install the tuners:

1. Place the neck fretboard down on a flat surface and insert the tuners into the headstock holes.
2. Position the tuners so they are perpendicular to the edge of the headstock, and mark the mounting holes (**Figure 16**).

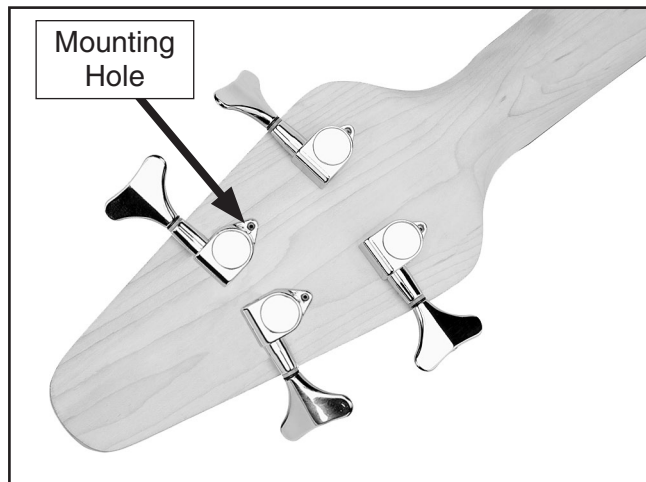

Figure 16. Tuners positioned.

3. Remove the tuners.
—If the neck is attached to the body, remove it now.
4. Place a backing board under the headstock and, using a 1/16" drill bit, drill four 3/8" deep holes into the back of the headstock at the marks from **Step 2** (**Figure 17**).



Figure 17. Drilling tuner mounting holes.

Note: *Drilling the holes deeper than 5/8" could result in drilling out through the top of the headstock. Set the correct depth with the depth stop on your drill press.*

5. Insert the tuner shafts through the holes in the back of the headstock and secure them with the #2 x 1/2" screws.
6. Turn the neck face up, slide a washer over each tuner post and screw a hex nut bushing onto each tuner, as shown in **Figure 18**.

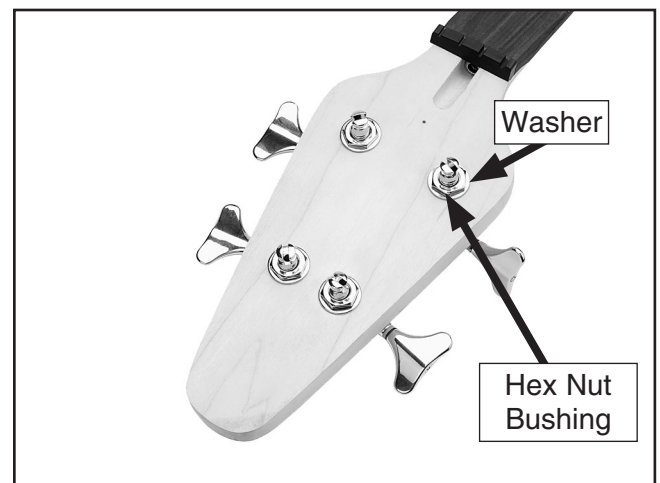

Figure 18. Tuners installed on headstock.



Wiring Pickups & Output Jack

This guitar comes with a wiring harness that has most of the components soldered in place. You only need to solder the pickup wires onto the volume control pots and the audio jack wire onto the output jack. If done incorrectly, the soldering can damage the components. If you are unsure of your skills, do your research, practice on scrap wires, or take it to someone with experience.

Refer to the **Wiring Diagram** on **Page 28** and the **Electrical Components** on **Page 27** while wiring the pickups and output jack.

Components and Hardware Needed:	Qty
Guitar Body	1
Wiring Harness	1
Bridge Pickup	1
Neck Pickup	1
Output Jack	1

To wire the pickups:

1. Remove the hex nut and flat washer from each control pot on the wiring harness.
2. Insert the control pots through the holes in the control cavity, and secure the pots on the front of the guitar with the hex nuts and washers removed in **Step 1**.
3. Insert the output jack into the hole in the end of the body (**Figure 19**) and secure it with the included hex nut.

4. Solder the audio jack wires onto the output jack, as shown in the **Wiring Diagram** on **Page 28** and the **Electrical Components** on **Page 27**.
5. Insert the ground wire through the hole in the control cavity and through the hole in the top of the body. Temporarily secure the end of the ground wire with masking tape.
6. Flip the guitar body face up, thread the pickup wires through the holes in the pickup cavities (**Figure 20**) and temporarily tape the pickups to the body with masking tape.

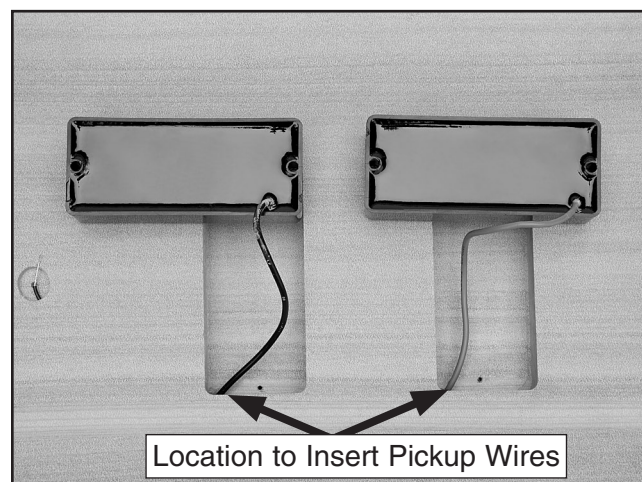

Figure 20. Pickup cavities.

7. Flip the guitar face down and solder the pickup wires onto the volume control pots, as shown in the **Wiring Diagram** on **Page 28** and the **Electrical Components** on **Page 27**.

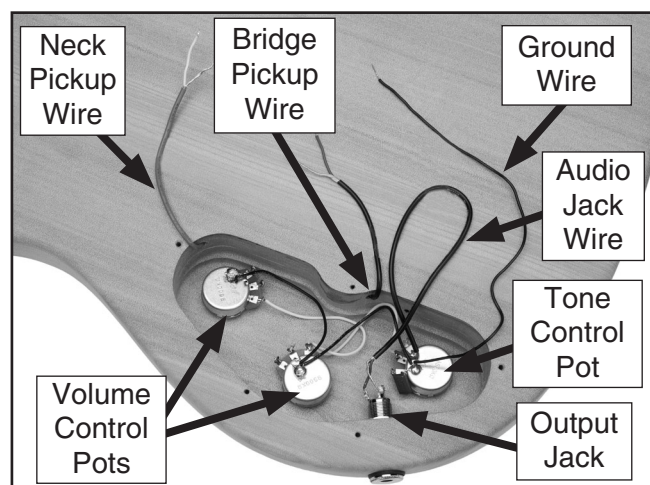

Figure 19. Wires threaded through control cavity.



Installing Bridge & Pickups

To reduce humming in your amp, the ground wire must contact the bridge plate.

Components and Hardware Needed:	Qty
Guitar Body	1
Bridge	1
Screws #4 x 1"	5
Control Cover Plate	1
Screws #4 x 1/2"	5
Pickups	2
Screws #2 x 1 ³ / ₈ "	5
Compression Springs	4

To install the bridge, control plate, and pickups:

1. Remove tape from the end of the ground wire and place the exposed portion of the wire over the edge of the ground wire cavity, as shown in **Figure 21**.

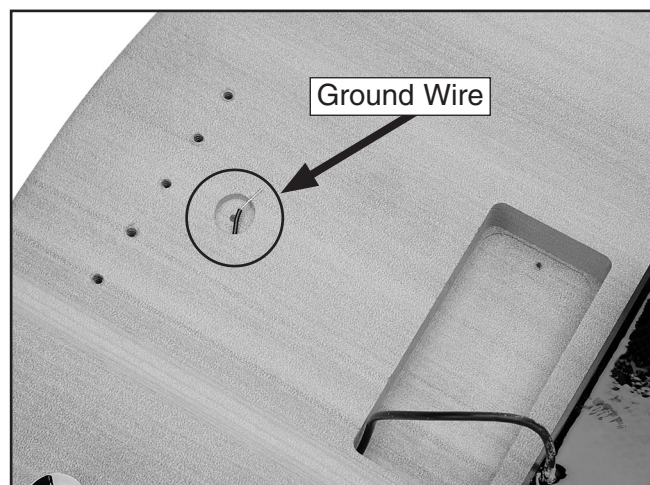

Figure 21. Ground wire above cavity.

2. Place the bridge over the cavity so the plate contacts the wire.
3. Secure the bridge with the #4 x 1" screws, as shown in **Figure 22**, making sure the saddle adjustment screw heads point away from the neck.

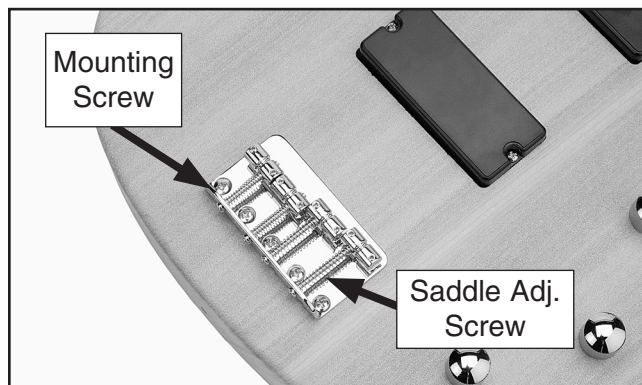

Figure 22. Bridge installed.

4. Place the control cover plate on the body so it completely covers the control cavity, silver foil side down, and mark the mounting holes.
5. Using a 5/64" bit, drill the mounting holes—being careful not to break off the cavity edges, and secure the control cover plate with the #4 x 1/2" screws.
6. Remove tape from the pickups, and install each pickup into a cavity with the two #2 x 1³/₈" screws and compression springs, as shown in **Figure 23**. Install the bridge pickup, which has a silver and red wire into the bridge cavity; install the neck pickup, which has a white and silver wire in the cavity closest to the neck.

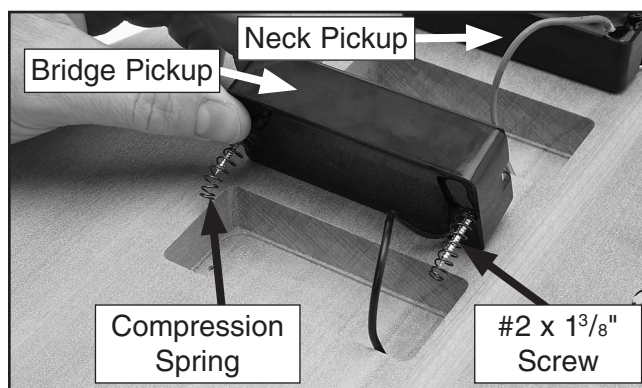

Figure 23. Installing pickups.

Note: The top of each pickup should be flat or even with the body, not angled. You will adjust the heights of the pickups later in this manual.



Strap Buttons

The strap buttons are positioned on the guitar as shown in **Figure 24**.

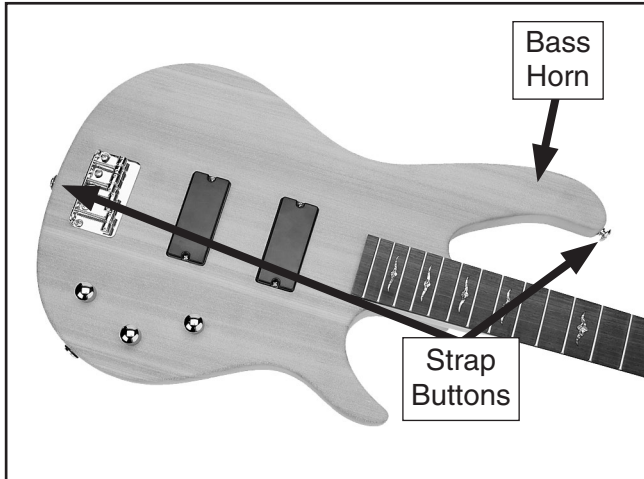

Figure 24. Strap button placement.

Components and Hardware Needed	Qty
Guitar Body	1
Screws #4 x 1"	2
Strap Buttons.....	2

To attach the strap buttons to the guitar:

1. If the strap button holes are not already drilled, use a $\frac{3}{32}$ " bit to drill $\frac{1}{2}$ " deep holes at the end of the guitar—on the center line—and on the bass horn (**Figure 24**).
2. Secure each of the strap buttons to the guitar body with a #4 x 1" screw.

Installing Nut

Components and Hardware Needed:	Qty
Guitar Body	1
Nut	1
Neck	1
Neckplate.....	1
Screws #10 x $1\frac{3}{4}$ "	4

To install the nut:

1. Use a chisel or razor blade to scrape any finish out of the nut slot. **DO NOT** remove any wood from the nut slot.
2. Slide the nut into the slot.

—If the nut will not fit into the slot, sand one side of the nut on a piece of sandpaper until it fits snugly into the slot as shown in **Figure 25**. **Note:** Make sure the large slots on the nut are toward the top of the neck.

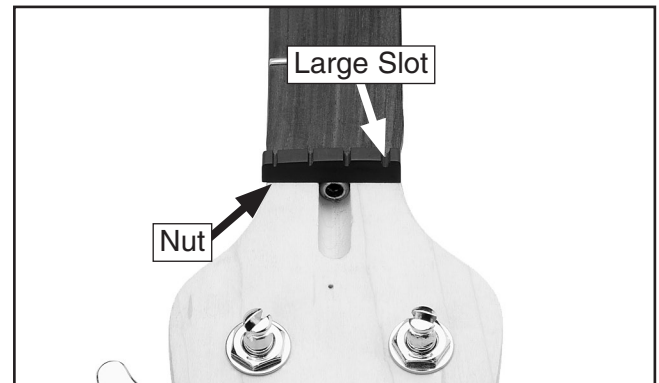

Figure 25. Nut installed.

3. Remove the nut, spread a thin layer of glue in the nut slot, and center the nut in the nut slot.
4. Install the neck onto the body using the #10 x $1\frac{3}{4}$ " screws and neckplate.
5. Install the truss rod cover and the strings, as described on **Page 17**, to hold the nut in place until the glue dries.
6. Wipe away the excess glue before it sets up, then allow the glue to dry for 24 hours.



Truss Rod Cover

Components and Hardware Needed:	Qty
Guitar.....	1
Truss Rod Cover.....	1
Screw #2 x 3/8".....	1

To install the truss rod cover:

1. Center the truss rod cover over the hole for the truss rod and press it against the nut.
2. Mark the mounting hole, use a 1/16" drill bit to drill a 3/8" deep hole into the headstock, and secure the truss rod cover with the #2 x 3/8" screw.



Figure 26. Truss rod cover installed.

Winding Strings

The correct position of the guitar strings is shown in **Figure 27**. The thin high "G" string is the "1st" (bottom) string and the thick low "E" string is the "4th" (top).

Components and Hardware Needed:	Qty
Guitar.....	1
Strings.....	4

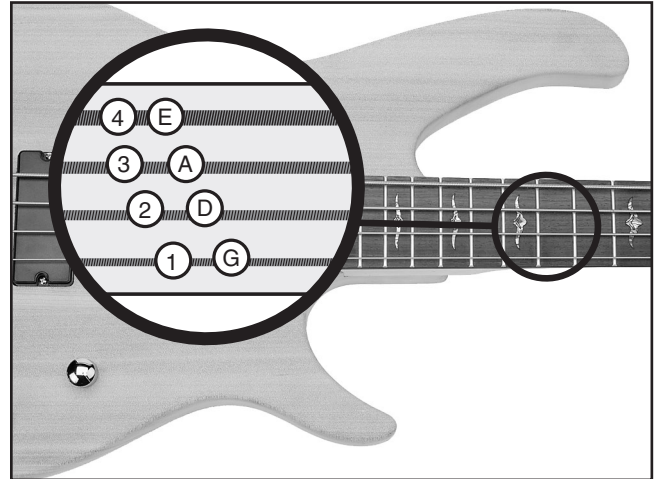

Figure 27. Example of correct string locations.

To install the strings:

1. Thread a string through the hole in the bridge (**Figure 28**) across the saddle, over the nut, and through the hole in the corresponding tuning post.

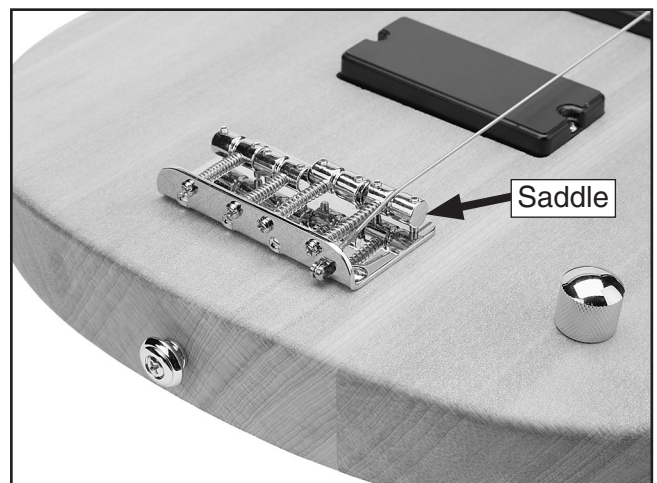

Figure 28. 1st string installed.



2. Allow only enough slack in the string for 2-3 rotations around the tuning post.

Note: *If too much slack is allowed, then the string could wind off the tuning post after many successive rotations. If not enough slack is allowed, then the string may not hold the winding tension.*

3. Use wire cutters (optional) to cut off excess string.
4. Bend the string at a right angle and insert it into the tuning post slot.
5. Rotate the tuners until the string just begins to hold the winding tension (**Figure 29**).

Note: *DO NOT tighten the strings beyond the initial tensioning at this time. Final tensioning should be completed during the string tuning process.*

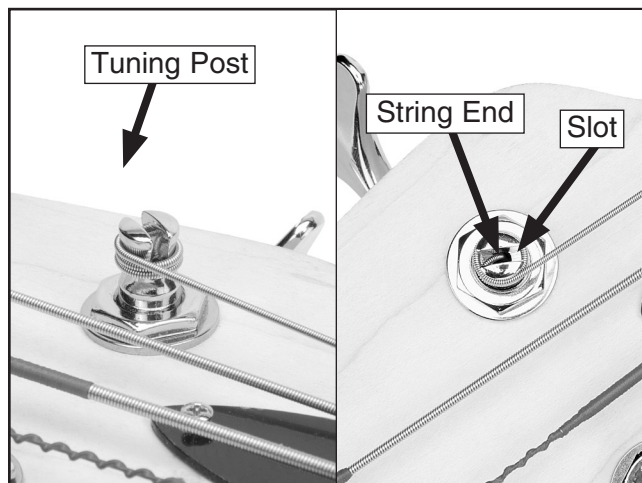

Figure 29. String wrapped around tuning post.

6. Repeat the above process for the remaining strings.



SECTION 5: SETUP

General

Guitar set up is an art that requires skill, patience and experience. If you have the patience, you can acquire the skill and experience. If you don't have the patience, you may want to have your guitar set up by a qualified guitar technician.

This section presents an overview of setup practices. We highly recommended that you research more in-depth methods. Books on setting up electric guitars can be ordered through Grizzly Industrial, luthier supply catalogs, or may be available through your local library.

Neck Adjustment

The guitar neck was adjusted perfectly straight before it was packaged; however, the moisture content of wood acclimates to the humidity of the surrounding environment. This characteristic results in movement of the wood components with regards to alignment. The neck may require adjustment several times each year, especially in regions where the seasonal climate changes are more drastic.

Components and Hardware Needed: Qty
Guitar with Strings Installed 1

Tools Needed

Metal Straightedge 18" 1
Hex Wrench 4mm..... 1
Feeler Gauge Set 1
Phillips Head Screwdriver..... 1

To adjust the bow of the guitar neck:

1. Tighten the strings to playing tension.

2. Place a straightedge between the G and D strings, from the 1st fret to the 17th. Measure any gaps between the straightedge and the frets with the feeler gauge to determine if the neck is straight, bowed up or bowed down (**Figure 30**). **Figure 31** shows an example of a slightly upbowed neck.

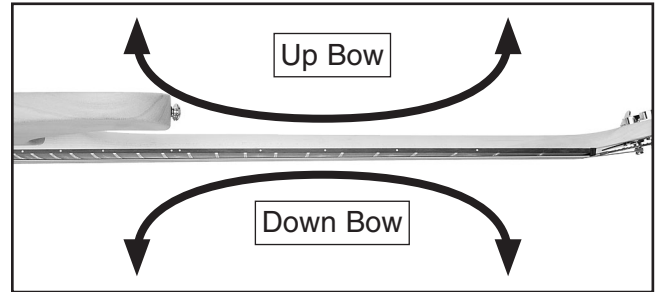

Figure 30. Neck bow.

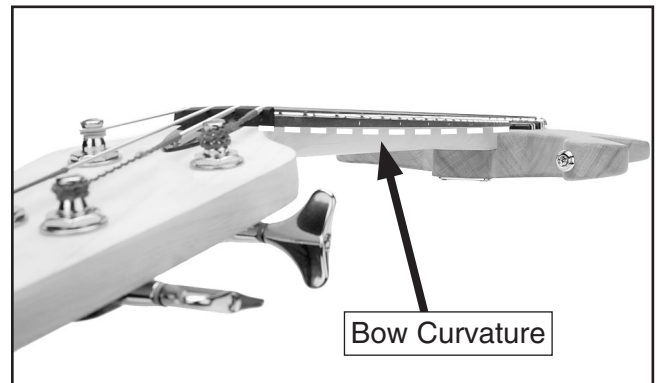

Figure 31. Slightly up-bowed neck (viewed down neck from headstock).

—If the neck is flat, or bowed up 0.012" or less, it is set up correctly. Continue to the next subsection.

—If the gap is greater than 0.012", or if the neck bows down away from the straight-edge, continue to **Step 3**.

Tip: *Your playing style will also dictate how much action (string height above the frets) your bass should have. For fast playing, low action, set the neck to bow up less than 0.012". Heavy-handed players or those who use a capo may want to adjust the neck to bow up more than 0.012".*



- Loosen the strings, turn the truss rod cover out of the way, and turn the truss rod nut in the base of the neck (**Figure 32**) counterclockwise to release tension on the neck. Retighten until the nut begins to grab.

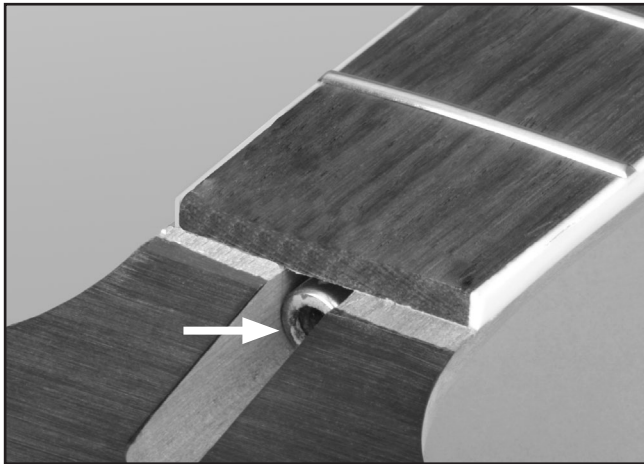

Figure 32. Example of truss rod nut.

- To flatten an up-bow, turn the truss rod nut a $\frac{1}{4}$ turn clockwise—tightening the truss rod. To correct a down-bow, turn the nut a $\frac{1}{4}$ turn counterclockwise—loosening the truss rod.
- Tighten the strings and recheck the neck with the straightedge.
 - If the neck is correctly adjusted, secure the truss rod cover, and go to the next subsection.
 - If the neck is still out of adjustment return to **Step 3**. It may take some trial and error to find the right amount of truss rod tension and neck bow.
- Replace the truss rod cover and tighten the strings.

String Height

Tools Needed	Qty
Hex Wrench 1.5mm.....	1
Guitar Capo.....	1
Metal Straightedge.....	1
Steel Ruler ($\frac{1}{64}$ " Resolution).....	1

Correct string height is crucial for maximizing the playability of your electric guitar. The action or string height is the distance between the top face of the fret and the bottom face of the string (**Figure 33**). Adjust the action depending upon your playing type. If you play with a light touch, set the action low, if you play heavy-handed, set the action higher to avoid fret buzz.

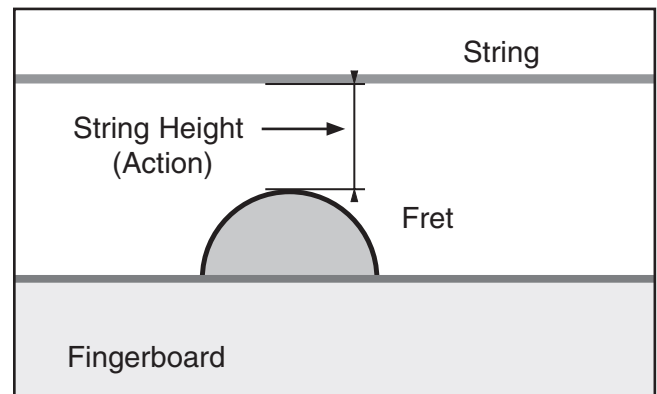

Figure 33. String height measurement.

To adjust the string height:

- Place a capo on the 1st fret.
- Measure the string height at the twelfth fret as shown in **Figure 34**.

The 1st (G) string measurement should be $\frac{5}{64}$ ", the 4th (Low E) string measurement should be $\frac{6}{64}$ ". This is a suggested range and the strings can be adjusted higher or lower depending upon your playing type.

—If the string heights are correct, then continue to **Pickup Height on Page 21**.

—If the string heights are incorrect at the 12th fret, then continue to the next step.



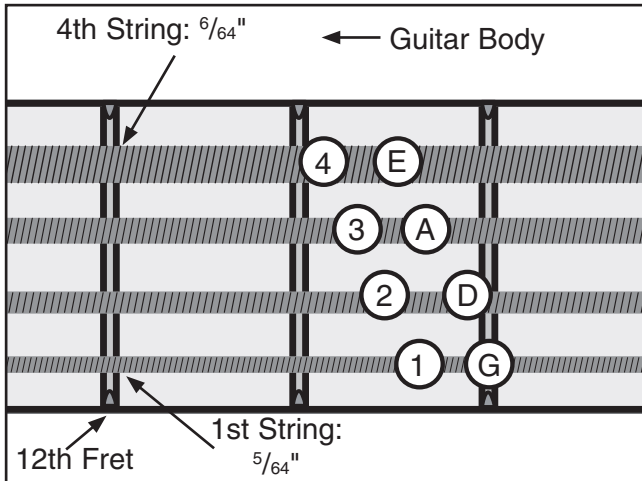

Figure 34. Correct 12th fret string heights.

- Use the included 1.5mm hex wrench to adjust the saddle height setscrews (**Figure 35**) until the string heights are correct.

—Turn the screws clockwise to raise the height of the string saddle, thus increasing the string height.

—Turn the screws counterclockwise to lower the height of the string saddle, thus decreasing the string height.

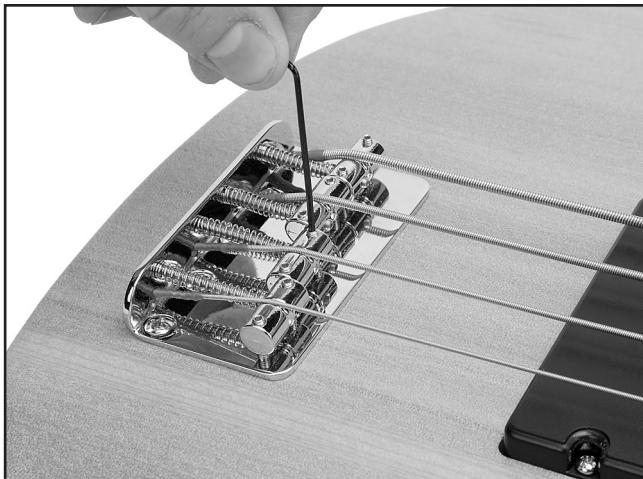

Figure 35. Adjusting string height.

- After setting the correct height for the 1st and 4th strings, adjust the middle strings so they gradually increase in height from the 1st string through the 4th string.
- Remove the capo.

Pickup Height

Pickup height can have a dramatic effect on the audio output signal. The closer the strings are to the pickup, the higher the audio output signal will be. If the strings are too close, distortion is caused by magnetic interference from the electronic components.

Tools Needed

	Qty
Metal Straightedge	1
Phillips Head Screwdriver.....	1

To measure the string height at the pickup:

- Measure the height of the 1st (G) and 4th (E) strings at the pickup while the strings are “fretted” at the 22nd fret (**Figure 36**).

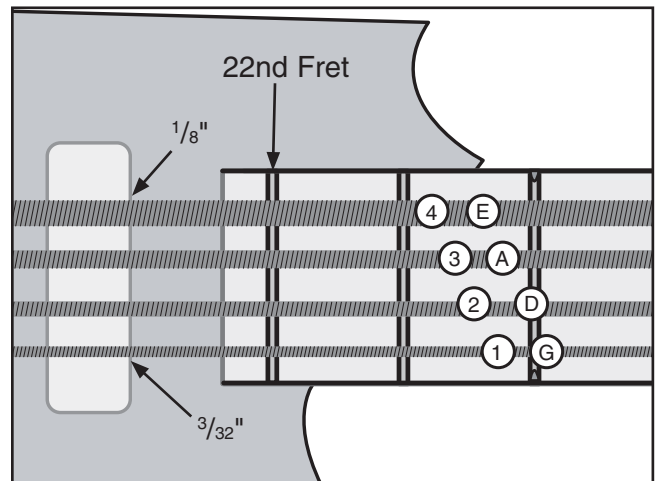

Figure 36. String heights over the pickup.

- With a Phillips head screwdriver, adjust the screws on each side of the pickup until the 1st (G) string is $\frac{3}{32}$ " above the pickup and the 4th (E) string is $\frac{1}{8}$ " above the pickup. This is a suggested range and the pickup can be adjusted higher or lower depending upon your playing type.

—Turn the screws counterclockwise to raise the height of the pickup, therefore, decreasing the string height.

—Turn the screws clockwise to lower the height of the pickup, therefore, increasing the string height.

- Repeat **Steps 1-2** for the other pickup.



Tuning

Tuning is an important guitar concept. If the guitar is not in tune, the resulting sound is unpleasant. These instructions explain how to tune by ear. You can also tune by using an electronic tuner such as the Grizzly H3097 Chromatic Tuner shown on **Page 23**.

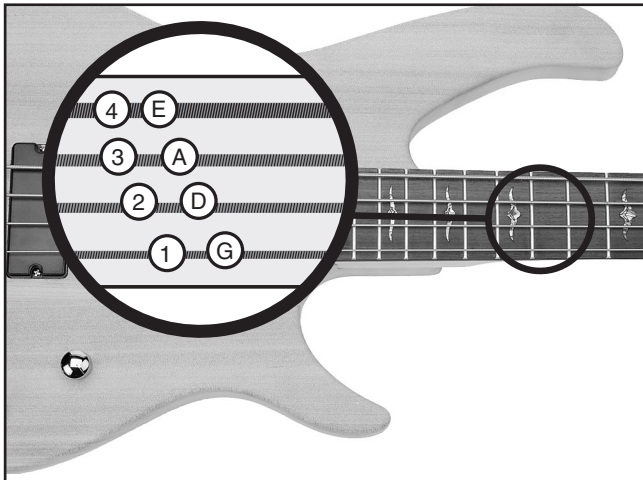

Figure 37. Example of standard tuning.

To tune the guitar:

1. Play a Low E pitch on a piano, a tuning fork, or an electronic computer file.
2. Play an open (non-fretted) 4th string and adjust the tuner to match the Low E.

Note: Always tune up. If the string is tuned high, loosen the string to lower the pitch, then tune the string up to the correct note.

3. Tune the 3rd string by playing the 4th string while it is being pressed (fretted) at the 5th fret, and then play the open 3rd string. Adjust the 3rd string tuner until the notes match.
4. Tune the 2nd string by playing the 3rd string while it is being pressed (fretted) at the 5th fret, and then play the open 2nd string. Adjust the 2nd string tuner until the notes match.
5. Perform the same tuning step on the 1st and 2nd string.

Setting Intonation

Tools Needed

Qty

Phillips Head Screwdriver..... 1

Setting the intonation adjusts the length of the string to correct for flatness/sharpness on each string. This is a simple process that takes a lot of trial and error.

To set the intonation:

1. Lightly touch and then release the 1st string directly above the twelfth fret as you pluck the string to play a harmonic note.
2. Now pluck the string while holding it fretted at the twelfth fret. If this note is sharper than the note played in **Step 1**, move the saddle away from the neck by turning the saddle adjustment screw (**Figure 38**) clockwise. If this note is flat in comparison, move the saddle toward the neck.

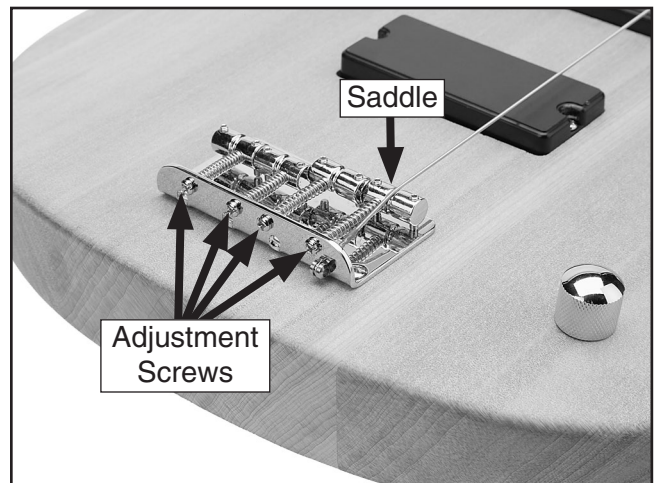

Figure 38. Saddle adjustment screws.

Note: This can also be done with an electronic tuner by tuning the harmonic note to be exactly in tune and then adjusting the saddle until the note played in **Step 2** is also in tune.

3. Repeat **Steps 1–2** until the string is in tune. Repeat the process for the rest of the strings.



SECTION 6: REFERENCE INFO

Accessories

T20501—Face Shield, 4" Crown, Clear
T20502—Face Shield, 7" Crown, Clear
T20448—Economy Clear Safety Glasses
T20452—"Kirova" Anti-Reflective Glasses
T20456—"Dakura" Clear Safety Glasses
H0736—Shop Fox® Safety Glasses
These glasses meet ANSI Z87.1-2003 specifications. Buy extras for visitors or employees. You can't be too careful with shop safety!

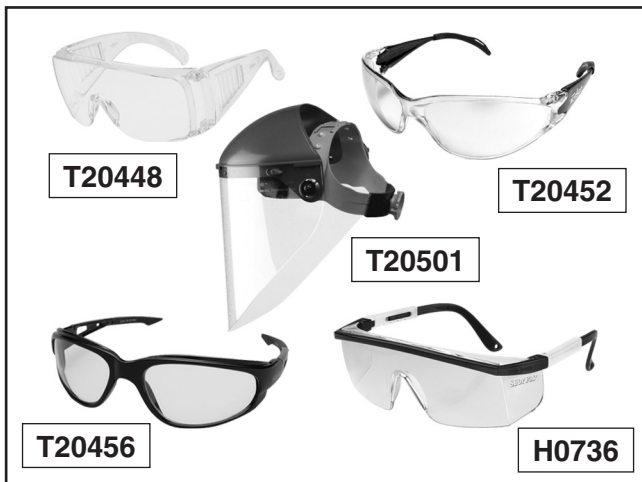

Figure 39. Our most popular eye protection.

H3097—Chromatic Tuner

An absolute must for any guitar player, this tuner allows you to tune your electric bass guitar dead on. Includes 9V battery.



Figure 40. Model H3097 Chromatic Tuner.

H0818—Fine Prepolishing Paste, 1.85 lb
H4873—Medium Prepolish Liquid, 1 Qt
H0821—High Gloss Polishing Liquid, 1 Qt
Menzerna professional polishing compounds will remove any fine scratches from the finish and give your instrument the incredibly high gloss finish that you are looking for.



Figure 41. Menzerna polishing compounds.

G9845—6 Pc. Hollow Punch Set

Punch perfectly round holes in one easy step. Includes knurl-gripped punches for 3/16", 1/4", 5/16", 3/8", 7/16" and 1/2" holes. Great for cutting gasket material!



Figure 42. Model G9845 Punch Set.

Call 1-800-523-4777 To Order



- H5750—Vinyl Washcoat/Sealer, 1Qt
- H5751—Nitrocellulose Lacquer, Gloss, 1 Qt
- H5752—Nitrocellulose Lacquer, Gloss, 1 Gal
- H5753—Nitrocellulose Lacquer, Satin, 1 Qt
- H5754—Nitrocellulose Lacquer, Satin, 1 Gal
- H5755—Retarder for Lacquer, 1 Qt
- H5756—Natural Filler, 1 Pint
- H5757—Mahogany Filler, 1 Pint
- H5759—Filler Reducer, 1Qt

McFadden's nitrocellulose lacquer is the leading lacquer used by custom guitar builders. It sprays and buffs really well and is capable of giving you a finish that looks "wet."



Figure 43. Model H5750-59 McFadden's Lacquers and Fillers.

G1530—Router Pad

This natural rubber pad eliminates holding or clamping work while routing or sanding. It effectively grips the workpiece for safe non-slip routing. Thin pad can be easily rolled up and stored when not in use. Pad measures 1/8" x 24" x 36"

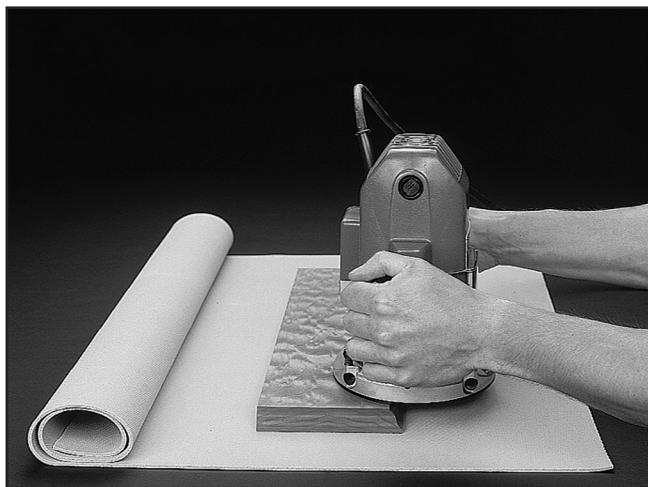

Figure 44. Model G1530 router pad.

- H2499—Small Half-Mask Respirator
- H3631—Medium Half-Mask Respirator
- H3632—Large Half-Mask Respirator
- H3633—Disposable Cartridge Filter Pair
- H3635—Disposable Cartridge Filter Pair

This lightweight elastomeric facepiece has cradle suspension, easy adjust headstraps and low profile for greater field of vision and compatibility with normal use of glasses or goggles. Purchase cartridges separately depending upon intended application.

Model H3633 protects against organic vapor, sulfur dioxide, hydrogen chloride and chlorine. Model H3635 protects against all particulate aerosols.



Figure 45. Half-mask respirator and disposable cartridge filters.

H6044—Samba® Deluxe Bass Strings-4

These medium tension longscale round-wound stainless steel bass strings include 0.045" G-first, 0.065" D-second, 0.085" A-third and 0.105" E-fourth.

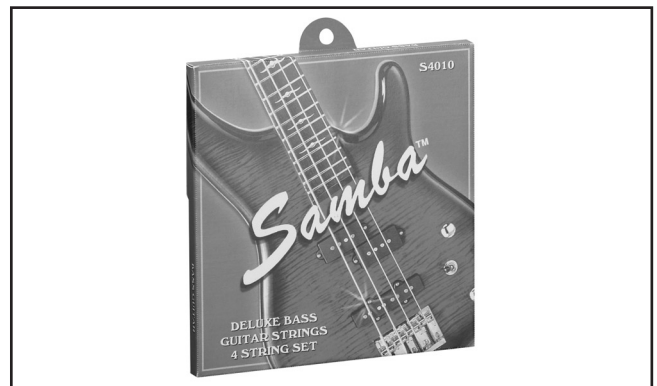

Figure 46. Model H6044 Bass Strings.

Call 1-800-523-4777 To Order



Premier Red Mirror Finish Silicon Carbide Waterproof Sandpaper

Model H8912—1000 Grit, 50 Pack

Model H8913—1200 Grit, 50 Pack

Model H8914—1500 Grit, 50 Pack

Model H8915—2000 Grit, 50 Pack

Ideal for producing very fine finishes in wet applications. Ultimate flexibility, and environmentally stable; resists humidity-caused curling. 50 sheets per package.

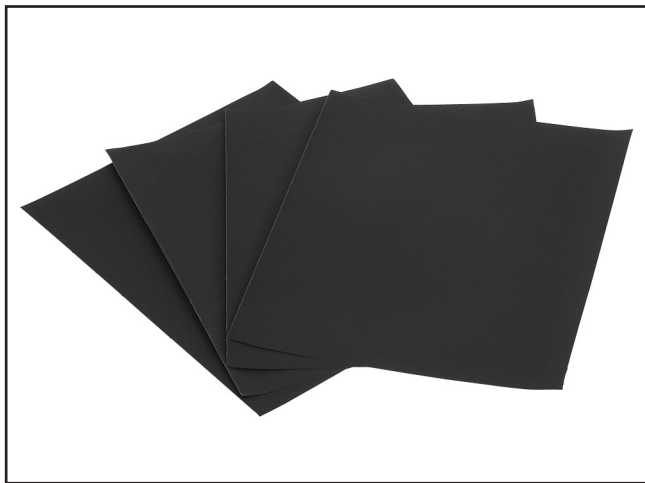

Figure 47. Model H8912 Sandpaper.

H3092—3-Pc Wood Rasp Set

This 3 piece. Wood rasp set with rubber handles includes round rasp, flat rasp and half-round rasp. Ideal for wood carvers. Aggressive teeth remove wood fast for any wood shaping need. Rasps measure 12" overall.

H3091—6-Pc Wood Rasp Set

Sure-grip rubber handles make this six-piece rasp file set a pleasure to use. Set includes round rasp file, square rasp file, half-round rasp file, triangular rasp file, flat rasp file and tapered flat rasp file. Rasp files measure 12¼" overall.

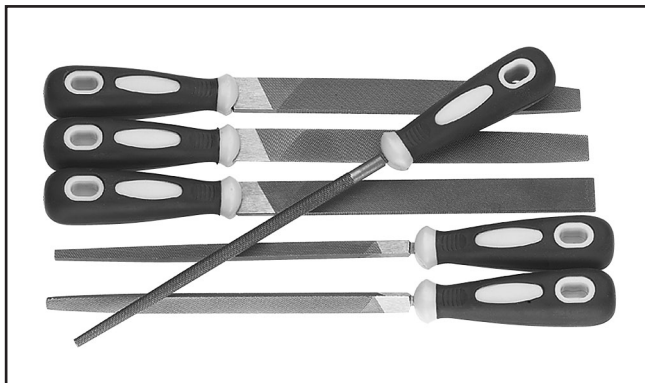

Figure 48. Model H3091 Rasp Set.

Light Paper Backed A/O Sandpaper

Model G6194—80 Grit, 10 Pack

Model G6195—100 Grit, 10 Pack

Model G6196—120 Grit, 10 Pack

Model G6197—150 Grit, 10 Pack

Model G6198—180 Grit, 10 Pack

Model G6199—220 Grit, 10 Pack

Wet/Dry Silicon Carbide Sandpaper

Model G6200—100 Grit, 10 Pack

Model G6201—120 Grit, 10 Pack

Model G6202—180 Grit, 10 Pack

Model G6203—220 Grit, 10 Pack

Model G6204—240 Grit, 10 Pack

Model G6205—320 Grit, 10 Pack

Model G6206—400 Grit, 10 Pack

We offer a variety of 9" x 11" sanding sheets in convenient 10 packs in 80 - 220 grits for just about any requirement.

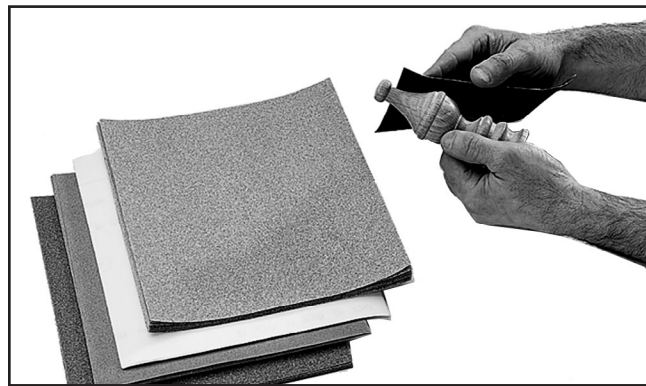

Figure 49. Assorted sandpaper.

G2500—16 pc. Long Sanding Drum Set

This kit consists of 5 drums in popular ½" x ½", ¾" x 1", 1" x 1", 1½" x 1½", and 2" x 1½" sizes. Comes with 50, 80 and 120 grit sleeve for each drum.



Figure 50. Model G2500 Sanding Drum Set.

Call 1-800-523-4777 To Order



H8787—FAQ: Bass Guitar Care And Setup

A hands-on guide to bass guitar repair. With photographs, diagrams, and sketches made by the author, John LeVan, and some provided by manufacturers. Learn how to: clean and condition a guitar, the re-stringing techniques of the professionals, adjust the neck, bridge saddle, string nut, pickups and intonation; and carve string nuts. 80 pages.

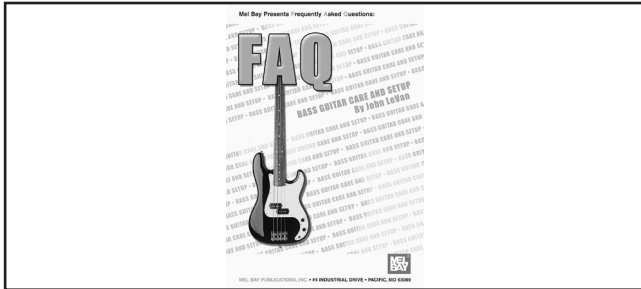

Figure 51. Model H8787 FAQ Book.

H6226—4½” Diagonal Side Cutters

These drop forged, professional quality wire cutters make a neat job of trimming off excess string lengths. A spring action device automatically opens the jaws and cushion grips provide excellent control. Overall length is 4½”.

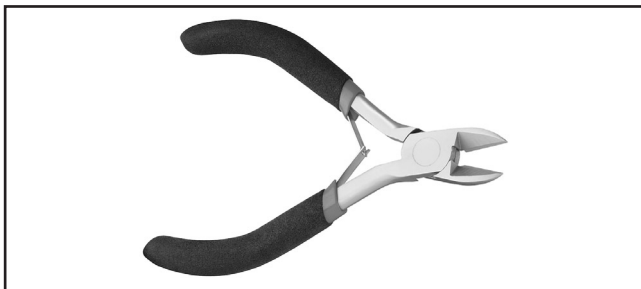

Figure 52. Model H6226 String Cutters.

H5524—30 Watt Bass Guitar Amplifier

- 30 watt output power with luxurious blue power LED.
- 1 x 10" custom made woofer. Closed back cabinet with two air port holes (on speaker baffle).
- Simple one input designed to handle both active and passive input. Headphone jack. Effect send, effect return (rear chassis).
- Volume and presence controls, three band passive EQ (low, mid, high).
- Very strong cabinet construction with a closed back and metal grill. Premium grade vinyl covering. Dimensions: 16"W X 12 ¼"D X 20 ½"H. 31 lbs.



Figure 53. Model H5524 Bass Guitar Amp.



Electrical Components

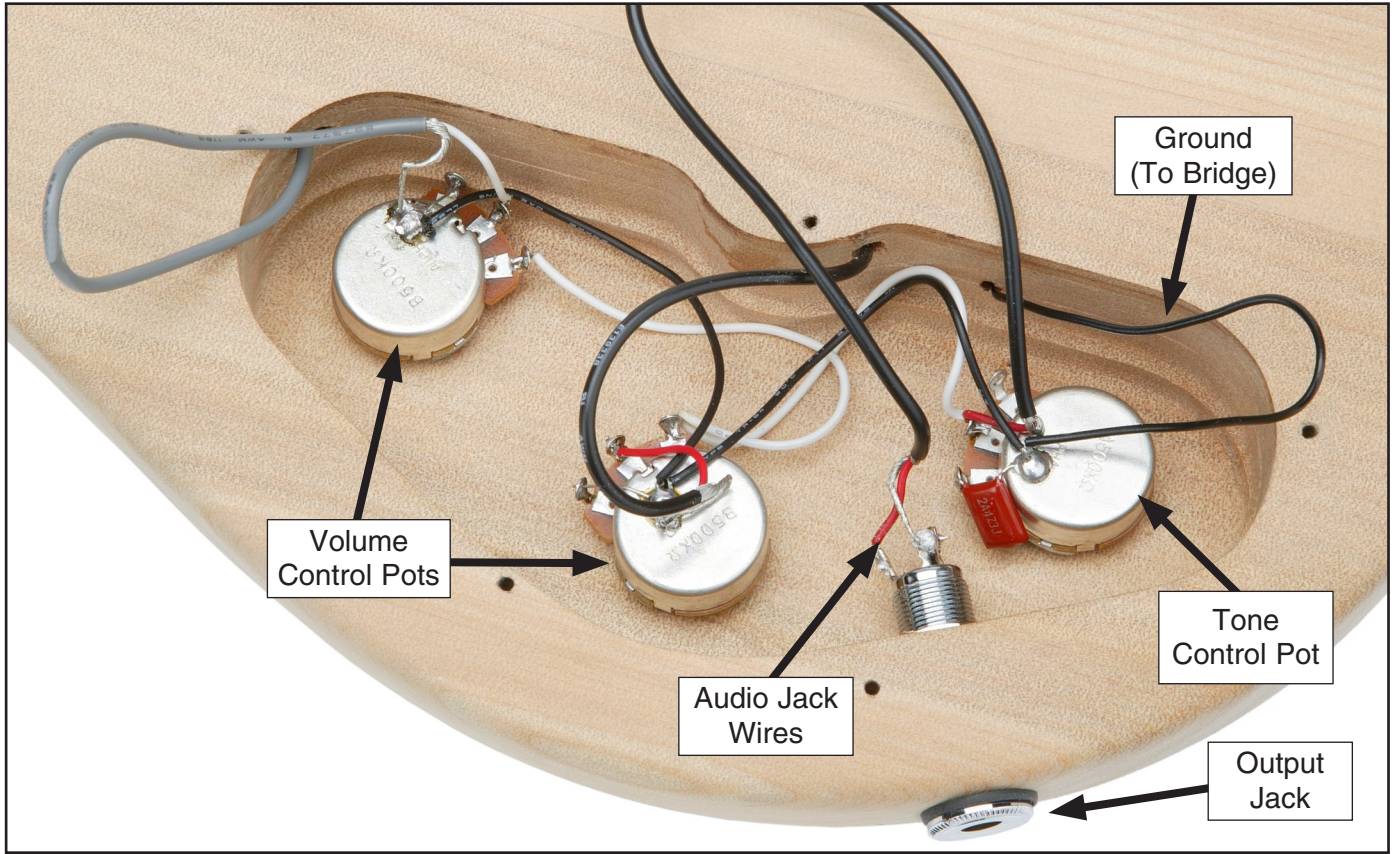

Figure 54. Control cavity wiring.

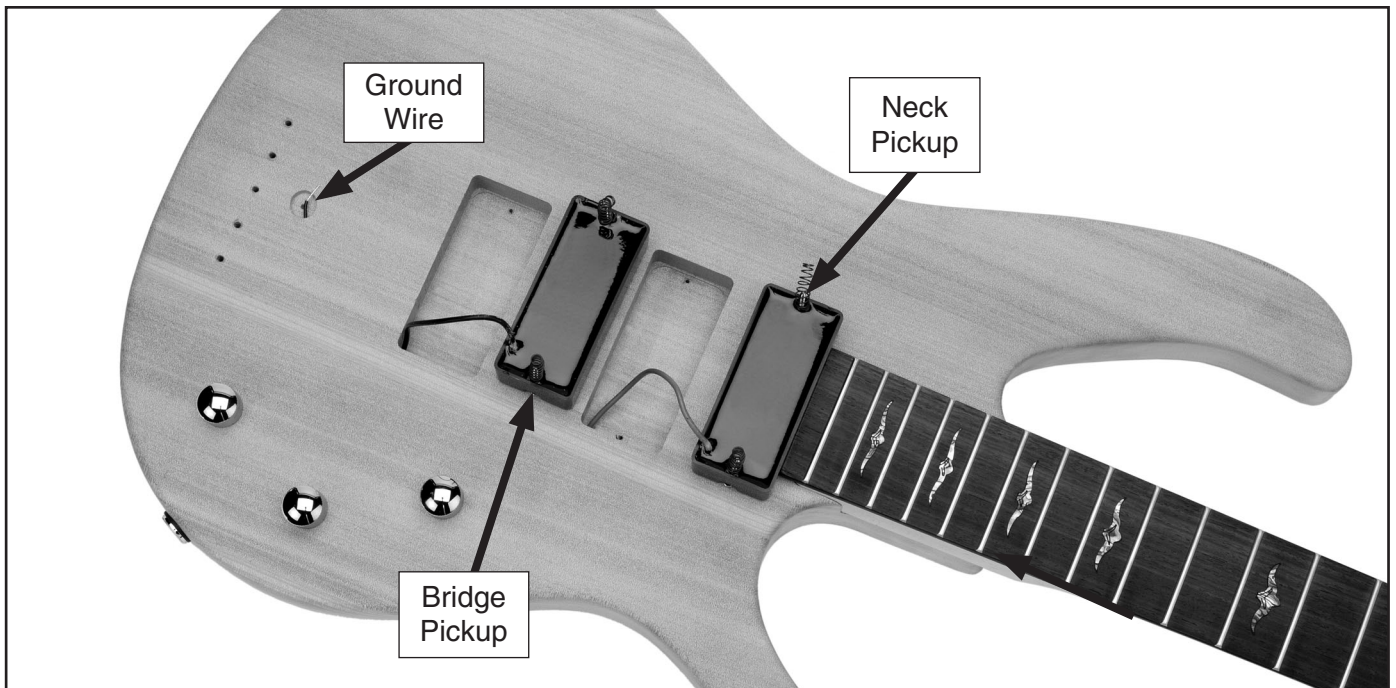

Figure 55. Bridge and pickup wiring.

Available in color online at www.grizzly.com



Wiring Diagram

Available in color online at www.grizzly.com



WIRE KEY	
BLACK	
WHITE	
RED	
EXPOSED WIRE	

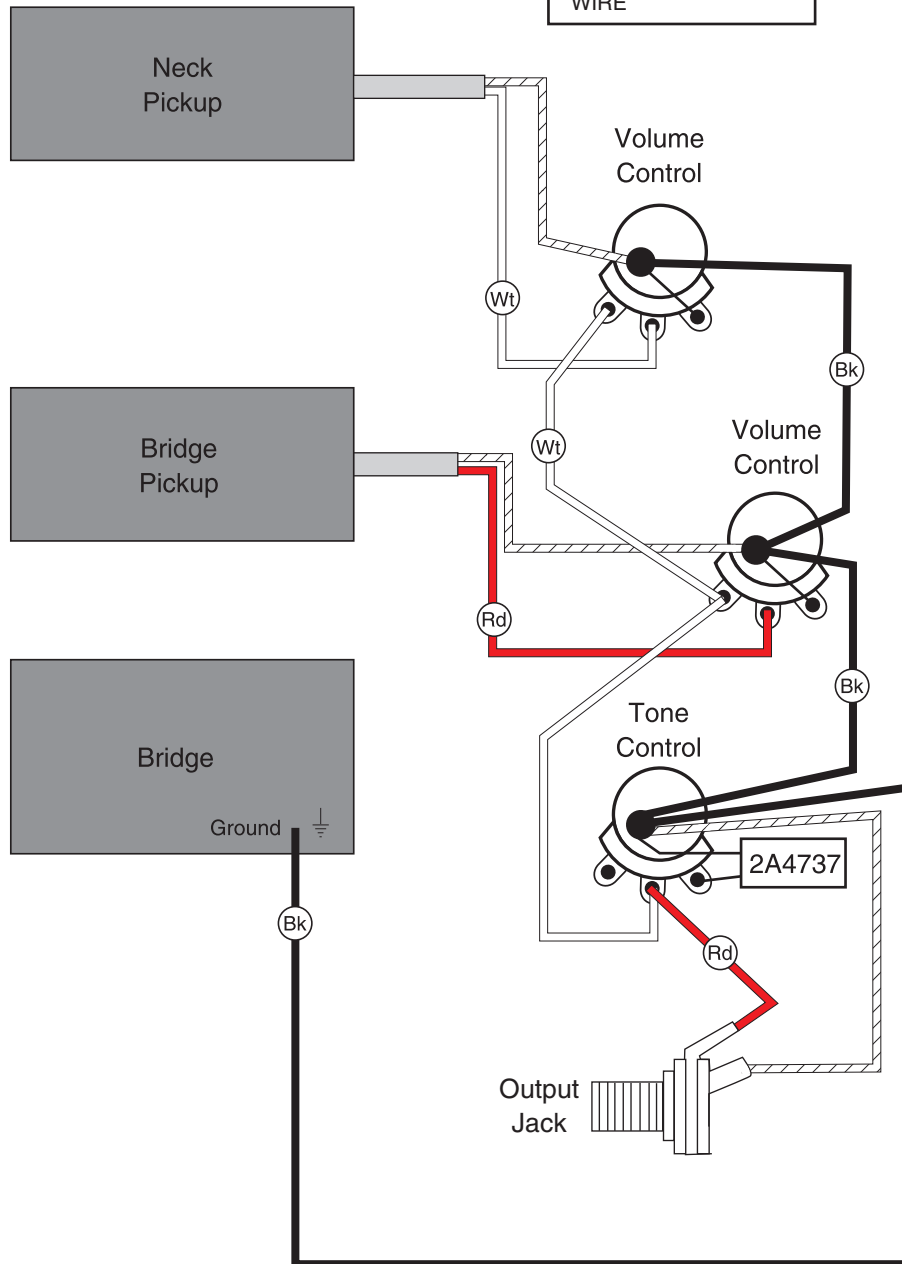

Figure 56. Model H8180/H8181 wiring diagram.





WARRANTY CARD

Name _____
 Street _____
 City _____ State _____ Zip _____
 Phone # _____ Email _____ Invoice # _____
 Model # _____ Order # _____ Serial # _____

The following information is given on a voluntary basis. It will be used for marketing purposes to help us develop better products and services. **Of course, all information is strictly confidential.**

1. How did you learn about us?

Advertisement Friend Catalog
 Card Deck Website Other:

2. Which of the following magazines do you subscribe to?

<input type="checkbox"/> Cabinet Maker	<input type="checkbox"/> Popular Mechanics	<input type="checkbox"/> Today's Homeowner
<input type="checkbox"/> Family Handyman	<input type="checkbox"/> Popular Science	<input type="checkbox"/> Wood
<input type="checkbox"/> Hand Loader	<input type="checkbox"/> Popular Woodworking	<input type="checkbox"/> Wooden Boat
<input type="checkbox"/> Handy	<input type="checkbox"/> Practical Homeowner	<input type="checkbox"/> Woodshop News
<input type="checkbox"/> Home Shop Machinist	<input type="checkbox"/> Precision Shooter	<input type="checkbox"/> Woodsmith
<input type="checkbox"/> Journal of Light Cont.	<input type="checkbox"/> Projects in Metal	<input type="checkbox"/> Woodwork
<input type="checkbox"/> Live Steam	<input type="checkbox"/> RC Modeler	<input type="checkbox"/> Woodworker West
<input type="checkbox"/> Model Airplane News	<input type="checkbox"/> Rifle	<input type="checkbox"/> Woodworker's Journal
<input type="checkbox"/> Modeltec	<input type="checkbox"/> Shop Notes	<input type="checkbox"/> Other:
<input type="checkbox"/> Old House Journal	<input type="checkbox"/> Shotgun News	

3. What is your annual household income?

\$20,000-\$29,000 \$30,000-\$39,000 \$40,000-\$49,000
 \$50,000-\$59,000 \$60,000-\$69,000 \$70,000+

4. What is your age group?

20-29 30-39 40-49
 50-59 60-69 70+

5. How long have you been a woodworker/metalworker?

0-2 Years 2-8 Years 8-20 Years 20+ Years

6. How many of your machines or tools are Grizzly?

0-2 3-5 6-9 10+

7. Do you think your machine represents a good value?

Yes No

8. Would you recommend Grizzly Industrial to a friend?

Yes No

9. Would you allow us to use your name as a reference for Grizzly customers in your area?

Note: We never use names more than 3 times. Yes No

10. Comments: _____

CUT ALONG DOTTED LINE

FOLD ALONG DOTTED LINE



Place Stamp Here



GRIZZLY INDUSTRIAL, INC.
P.O. BOX 2069
BELLINGHAM, WA 98227-2069



FOLD ALONG DOTTED LINE

Send a Grizzly Catalog to a friend:

Name _____
Street _____
City _____ State _____ Zip _____

TAPE ALONG EDGES--PLEASE DO NOT STAPLE

WARRANTY AND RETURNS

Grizzly Industrial, Inc. warrants every product it sells for a period of **1 year** to the original purchaser from the date of purchase. This warranty does not apply to defects due directly or indirectly to misuse, abuse, negligence, accidents, repairs or alterations or lack of maintenance. This is Grizzly's sole written warranty and any and all warranties that may be implied by law, including any merchantability or fitness, for any particular purpose, are hereby limited to the duration of this written warranty. We do not warrant or represent that the merchandise complies with the provisions of any law or acts unless the manufacturer so warrants. In no event shall Grizzly's liability under this warranty exceed the purchase price paid for the product and any legal actions brought against Grizzly shall be tried in the State of Washington, County of Whatcom.

We shall in no event be liable for death, injuries to persons or property or for incidental, contingent, special, or consequential damages arising from the use of our products.

To take advantage of this warranty, contact us by mail or phone and give us all the details. We will then issue you a "Return Number," which must be clearly posted on the outside as well as the inside of the carton. We will not accept any item back without this number. Proof of purchase must accompany the merchandise.

The manufacturers reserve the right to change specifications at any time because they constantly strive to achieve better quality equipment. We make every effort to ensure that our products meet high quality and durability standards and we hope you never need to use this warranty.

Please feel free to write or call us if you have any questions about the machine or the manual.

Thank you again for your business and continued support. We hope to serve you again soon.

grizzly.com

TOOL WEBSITE

Buy Direct and Save with Grizzly® – Trusted, Proven and a Great Value!

*Visit Our Website Today And Discover
Why Grizzly® Is The Industry Leader!*

- SECURE ORDERING
- ORDERS SHIPPED WITHIN 24 HOURS
- E-MAIL RESPONSE WITHIN ONE HOUR

-OR-

Call Today For A **FREE**
Full Color Catalog

1-800-523-4777

