

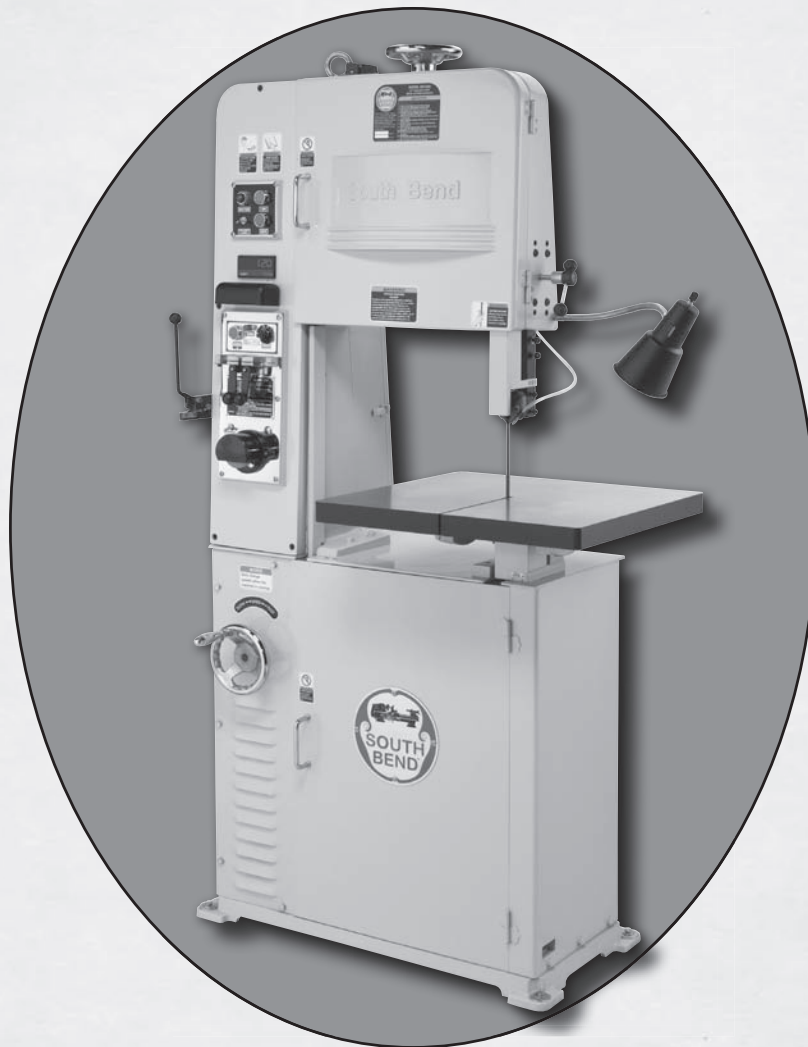

18" METAL CUTTING BANDSAW

MODEL SB1040 - SINGLE-PHASE

MODEL SB1041 - THREE-PHASE



OWNER'S MANUAL

South Bend Lathe Co.TM

Hundreds of Thousands of Lathes Sold With a Tradition of Quality Since 1906!



Scope of Manual

This manual helps the reader understand the machine, how to prepare it for operation, how to control it during operation, and how to keep it in good working condition. We assume the reader has a basic understanding of how to operate this type of machine, but that the reader is not familiar with the controls and adjustments of this specific model. As with all machinery of this nature, learning the nuances of operation is a process that happens through training and experience. If you are not an experienced operator of this type of machinery, read through this entire manual, then learn more from an experienced operator, schooling, or research before attempting operations. Following this advice will help you avoid serious personal injury and get the best results from your work.

Manual Feedback

We've made every effort to be accurate when documenting this machine. However, errors sometimes happen or the machine design changes after the documentation process—so the manual may not exactly match your machine. If a difference between the manual and machine leaves you in doubt, contact our customer service for clarification.

We highly value customer feedback on our manuals. If you have a moment, please share your experience using this manual. What did you like about it? Is there anything you would change to make it better? Did it meet your expectations for clarity, professionalism, and ease-of-use?

South Bend Lathe, Inc.
c/o Technical Documentation Manager
P.O. Box 2027
Bellingham, WA 98227
Email: manuals@southbendlathe.com

Updates

For your convenience, any updates to this manual will be available to download free of charge through our website at:

www.southbendlathe.com

Customer Service

We stand behind our machines. If you have any service questions, parts requests or general questions about the machine, feel free to contact us.

South Bend Lathe Co.
P.O. Box 2027
Bellingham, WA 98227
Phone: (360) 734-1540
Parts Department: (417) 886-2954
Fax: (360) 676-1075 (International)
Fax: (360) 734-1639 (USA Only)
Email: cs@southbendlathe.com

Table of Contents

INTRODUCTION.....	3	OPERATION.....	22
About This Machine.....	3	Operation Overview.....	22
Capabilities.....	3	Controls.....	23
Features.....	3	Blade Selection.....	24
Identification.....	4	Blade Terminology.....	24
Machine Specifications.....	5	Blade Length.....	24
SAFETY.....	9	Blade Width.....	24
Understanding Risks of Machinery.....	9	Tooth Set.....	25
Basic Machine Safety.....	9	Tooth Type.....	25
Additional Metal Cutting Bandsaw Safety.....	11	Blade Pitch (TPI).....	26
PREPARATION.....	12	Blade Changes.....	27
Preparation Overview.....	12	Blade Tension.....	27
Things You'll Need.....	12	Blade Breakage.....	28
Power Supply Requirements.....	13	Blade Care & Break-In.....	28
Availability.....	13	Blade Care.....	28
Full-Load Current Rating.....	13	Blade Break-In.....	28
Circuit Information.....	13	Blade Speed Chart.....	29
SB1040 Circuit Requirements at 110V.....	13	Chip Inspection Chart.....	29
SB1040 Circuit Requirements at 220V.....	13	Positioning Guide Post.....	30
SB1041 Circuit Requirements.....	14	Adjusting Blade Guides.....	30
Grounding Requirements.....	14	Tilting Table.....	32
Extension Cords.....	15	Blade Welding.....	32
Unpacking.....	15	Circle Cutting Jig.....	36
Inventory.....	15	MAINTENANCE.....	37
Cleaning & Protecting.....	16	Maintenance Schedule.....	37
Location.....	17	Cleaning.....	37
Lifting & Moving.....	18	Dressing Grinding Wheel.....	37
Securing to Floor.....	18	Lubrication.....	38
Bolting to Concrete Floors.....	18	V-Belts.....	39
Machine Mounts.....	19	Speed Hub Belts.....	39
Assembly.....	19	Sprocket Drive Belt.....	39
Initial Lubrication.....	19	Air Pump Belt.....	39
Power Connection.....	20	Dressing Rubber Tires.....	39
220V Conversion for SB1040.....	20	Machine Storage.....	40
Correcting Phase Polarity (SB1041 Only).....	20		
Test Run.....	21		
Inspections & Adjustments.....	21		

SERVICE.....	41	PARTS.....	55
Blade Tracking.....	41	Bottom Frame	55
Table Calibration	41	Drivetrain.....	57
Guide Post Alignment.....	42	Top Frame	59
Bevel Gear Backlash.....	43	Table	61
Leadscrew End Play	43	Welding Station & Control Panel	62
TROUBLESHOOTING.....	44	Digital Tachometer System.....	64
ELECTRICAL.....	48	Electrical Cabinet	65
Electrical Safety Instructions	48	Circle Cutting Jig.....	66
Wiring Overview	49	Machine Labels	67
SB1040/SB1041 Control Panel/Welding Unit ..	50	WARRANTY & RETURNS.....	69
SB1040 110V Electrical Panel, Motor & Cord .	51		
SB1040 220V Electrical Panel, Motor & Cord .	52		
SB1041 220V Electrical Panel, Motor & Cord .	53		
Electrical Component Pictures.....	54		

About This Machine

Capabilities

This 18" Metal-Cutting Bandsaw allows you to make exterior and interior contoured or straight cuts.

To better understand these capabilities, imagine making a "doughnut" out of 1" steel plate:

The outside circular shape can be easily cut by moving the workpiece around the blade, using a pre-drawn line as a cutting guide.

Cutting the inside hole would normally be a difficult task with a bandsaw. But this machine makes it easy. First, the bandsaw blade is cut with the built-in blade shear. A hole slightly larger than the blade is then drilled into the center of the workpiece, so the blade can be threaded through the hole. The ends of the blade are then clamped into the built-in welder, welded back together, annealed, and ground flat with the built-in grinder. Once the blade is re-installed on the wheels, it can then be used to cut the interior hole and complete the doughnut shape. After completion, the blade is sheared again to remove it from the workpiece.

Aside from the above capabilities, this machine can also be used for straight cuts in sheets too large to fit in the vise of a horizontal metal-cutting bandsaw

For example, if you needed to cut a 24" x 24" sheet of 1" steel in half, you can clamp a straightedge to the bandsaw table, then guide the sheet along the straightedge to make a straight cut. Cutting this same size of stock on a horizontal bandsaw would require a very large machine.

On the other hand, if you need to "resaw" an 8" x 8" billet into a series of 1" thick plates, clamp a straightedge 1" away from the blade, raise the blade guides to accommodate the height of the billet, and each cut you make will produce an 8" x 1" plate.

Both of these types of straight cuts can also be made with the table tilted to 15°, which creates a beveled cut.

Features

Now that you know the basics of what this machine can do, take a minute to consider its features.

This machine is equipped with a built-in air blower near the blade guides. This feature keeps metal chips away from the cutting area, so you can accurately follow pre-drawn cutting lines without metal chips getting in the way.

The table tilts in both the X- and Y-Axis with 15° of tilt to the left or right and 10° of tilt to the front or back.

An adjustable work lamp is also provided above the table to eliminate shadows from the work area. This is a great feature when doing close up work near moving blades!

We also equipped this bandsaw with infinitely variable blade speeds, so you can precisely control cutting results for the type of blade installed and type of material being cut. This is a great feature to have when doing precision cutting.

Aside from these features, we designed this machine to be extremely solid and durable. We used heavy gauge steel for the wheel doors, thick table trunnions and frame castings, USA-made Allen-Bradley electronics, and Japanese-made NSK ball bearings.

Identification

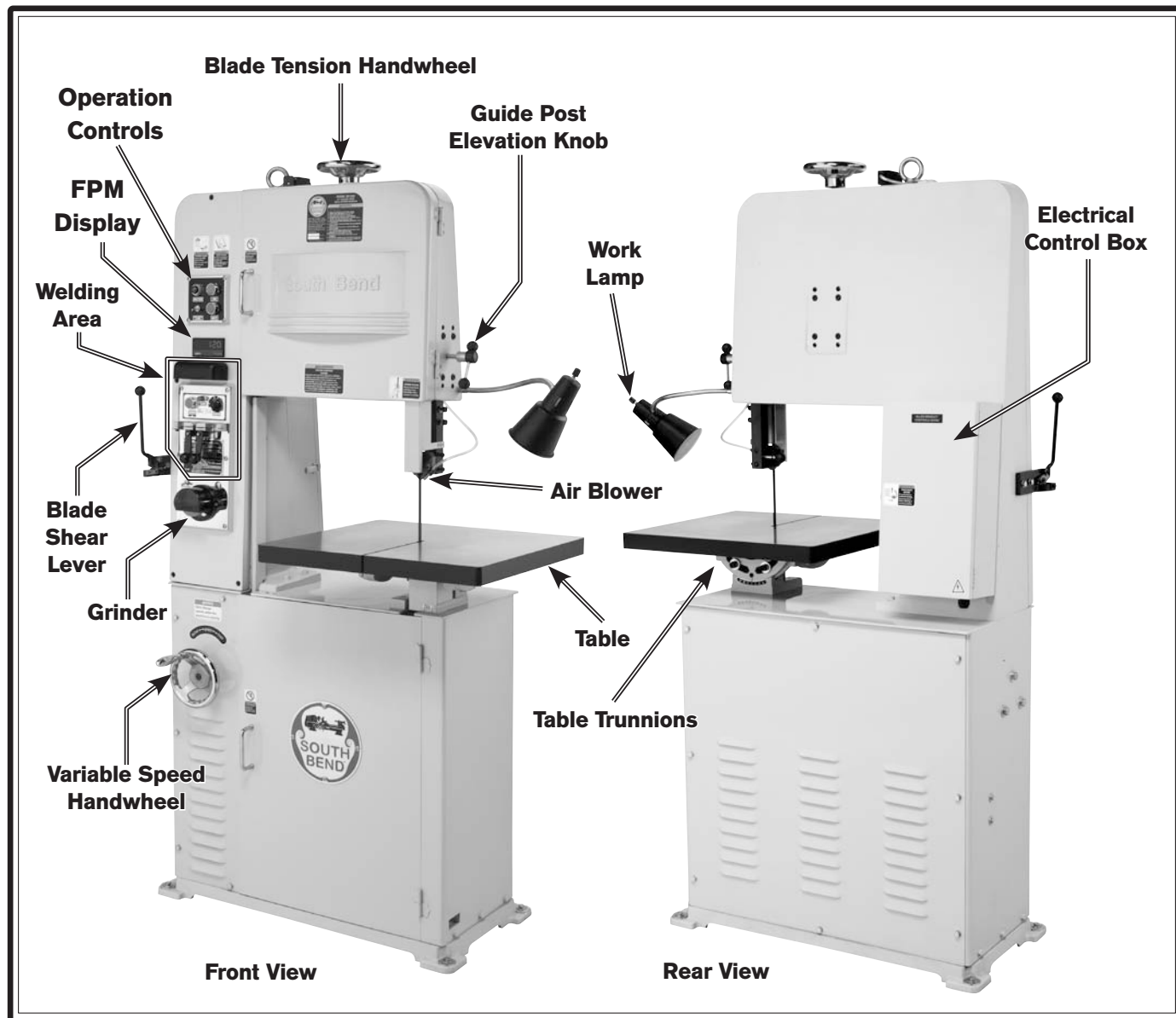

⚠ WARNING
 Serious personal injury could occur if you connect the machine to power before completing the setup process. **DO NOT** connect power until instructed to do so later in this manual.

⚠ WARNING
 Untrained users have an increased risk of seriously injuring themselves with this machine. Do not operate this machine until you have understood this entire manual and received proper training.



Model SB1040 South Bend 18" Vertical Bandsaw - 1PH

Product Dimensions

Weight..... 803 lbs.
 Width (side-to-side) x Depth (front-to-back) x Height..... 43-1/2 x 21-1/4 x 73-1/2 in.
 Footprint (Length x Width)..... 16-1/4 x 34 in.

Shipping Dimensions

Type..... Wood
 Content..... Machine
 Weight..... 999 lbs.
 Length x Width x Height..... 85 x 44 x 30 in.

Electrical

Power Requirement..... 110V or 220V, Single-Phase, 60 Hz
 Prewired Voltage..... 110V
 Minimum Circuit Size..... 20A at 110V, 15A at 220V
 Switch..... Magnetic Contactor with Thermal Overload Relay
 Switch Voltage..... 110V/220V
 Plug Included..... Yes
 Included Plug Type..... NEMA 5-15 for 110V
 Recommended Plug/Outlet Type..... NEMA 6-15 for 220V

Motors

Main

Type..... TEFC Capacitor Start Induction
 Horsepower..... 1 HP
 Voltage..... 110V/220V
 Prewired..... 110V
 Phase..... Single-Phase
 Amps..... 12A at 110V, 6A at 220V
 Speed..... 1725 RPM
 Cycle..... 60 Hz
 Number of Speeds..... 1
 Power Transfer Belt Drive
 Bearings..... Shielded and Permanently Lubricated

Grinder

Type..... Open Drip Proof Induction
 Horsepower..... 1/8 HP
 Voltage..... 110V
 Phase..... Single-Phase
 Amps..... 0.6A
 Speed..... 3450 RPM
 Cycle..... 60 Hz
 Number of Speeds..... 1
 Power Transfer Direct Drive
 Bearings..... Sealed and Lubricated

Main Specifications

Operation Info

Blade Speeds..... 88 — 384 FPM
 Blade Size Range..... 139-3/8 — 140-1/2 in.

Cutting Capacities

Cutting Height..... 9-5/8 in.
 Cutting Capacity Left of Blade..... 17-9/16 in.

Construction

Table..... Precision-Ground Cast Iron
 Upper Wheel..... Balanced Cast Iron
 Lower Wheel..... Balanced Cast Iron
 Tire..... Rubber
 Body..... Cast Iron (Upper), Steel (Lower)
 Base..... Cast Iron
 Wheel Cover..... Cast Aluminum (Upper), Pre-Formed Steel (Lower)
 Paint..... Urethane

Other

Wheel Size..... 18-1/8 in.
 Blade Guides Upper..... Hardened Steel/Tungsten
 Blade Guides Lower..... Hardened Steel/Tungsten
 Electric Blade Welder..... 2.4 KVA
 Blade Welding Station Voltage..... 220V
 Annealing Voltage..... 220V

Table Info

Table Tilt..... 15 Left, 15 Right, 10 deg. Fwd/Back
 Table Size Length..... 19-7/8 in.
 Table Size Width..... 22-1/8 in.
 Table Size Thickness..... 1-5/8 in.
 Floor To Cutting Area Height..... 38-1/2 in.

Other

Country Of Origin Taiwan
 Warranty 1 Year
 Serial Number Location ID Label on Upper Wheel Door
 Assembly Time 1 Hour



Model SB1041

South Bend 18" Vertical Bandsaw - 3PH

Product Dimensions

Weight..... 803 lbs.
 Width (side-to-side) x Depth (front-to-back) x Height..... 43-1/2 x 21-1/4 x 73-1/2 in.
 Footprint (Length x Width)..... 16-1/4 x 34 in.

Shipping Dimensions

Type..... Wood
 Content..... Machine
 Weight..... 999 lbs.
 Length x Width x Height..... 85 x 44 x 30 in.

Electrical

Power Requirement..... 220V, 3-Phase, 60 Hz
 Minimum Circuit Size..... 15A
 Switch..... Magnetic Contactor with Thermal Overload Relay
 Switch Voltage..... 220V
 Plug Included..... No
 Recommended Plug/Outlet Type..... NEMA L15-15

Motors

Main

Type..... TEFC Capacitor Start Induction
 Horsepower..... 1 HP
 Voltage..... 220V
 Phase..... 3-Phase
 Amps..... 3A
 Speed..... 1725 RPM
 Cycle..... 60 Hz
 Number of Speeds..... 1
 Power Transfer Belt Drive
 Bearings..... Shielded and Permanently Lubricated

Grinder

Type..... Open Drip Proof Induction
 Horsepower..... 1/8 HP
 Voltage..... 110V
 Phase..... Single-Phase
 Amps..... 0.6A
 Speed..... 3450 RPM
 Cycle..... 60 Hz
 Number of Speeds..... 1
 Power Transfer Direct Drive
 Bearings..... Sealed and Lubricated

Main Specifications

Operation Info

Blade Speeds..... 88 — 384 FPM
 Blade Size Range..... 139-3/8 — 140-1/2 in.

Cutting Capacities

Cutting Height..... 9-5/8 in.
 Cutting Capacity Left of Blade..... 17-9/16 in.

Construction

Table..... Precision-round Cast Iron
 Upper Wheel..... Balanced Cast Iron
 Lower Wheel..... Balanced Cast Iron
 Tire..... Rubber
 Body..... Cast Iron (Upper), Steel (Lower)
 Base..... Cast Iron
 Wheel Cover..... Cast Aluminum (Upper), Pre-Formed Steel (Lower)
 Paint..... Urethane

Other

Wheel Size..... 18-1/2 in.
 Electric Blade Welder..... 2.4 KVA
 Blade Welding Station Voltage..... 220V
 Annealing Voltage..... 220V

Table Info

Table Tilt..... 15 Left, 15 Right, 10 deg. Fwd/Back
 Table Size Length..... 19-7/8 in.
 Table Size Width..... 22-1/18 in.
 Table Size Thickness..... 1-5/8 in.
 Floor To Cutting Area Height..... 38-1/2 in.

Other

Country Of Origin Taiwan
 Warranty 1 Year
 Serial Number Location ID Label on Upper Wheel Door
 Assembly Time 1 Hour

Features

- Allen Bradley Controls
- Welding Station for Joining Blade Ends
- Includes Blade Cutter, Electric Welder w/Clamp, Annealer, and Grinder
- Infinitely Variable Cutting Speeds Between 88 — 384 FPM
- Lower Wheel Cleaning Brush
- Work Light
- Chip Blower
- Rubber Bonded Saw Wheels
- Digital Speed Display
- Circle Cutting Attachment

Understanding Risks of Machinery

Operating all machinery and machining equipment can be dangerous or relatively safe depending on how it is installed and maintained, and the operator's experience, common sense, risk awareness, working conditions, and use of personal protective equipment (safety glasses, respirators, etc.).

The owner of this machinery or equipment is ultimately responsible for its safe use. This responsibility includes proper installation in a safe environment, personnel training and usage authorization, regular inspection and maintenance, manual availability and comprehension, application of safety devices, integrity of cutting tools or accessories, and the usage of approved personal protective equipment by all operators and bystanders.

The manufacturer of this machinery or equipment will not be held liable for injury or property damage from negligence, improper training, machine modifications, or misuse. Failure to read, understand, and follow the manual and safety labels may result in serious personal injury, including amputation, broken bones, electrocution, or death.

The signals used in this manual to identify hazard levels are defined as follows:



Death or catastrophic harm WILL occur.



Moderate injury or fire MAY occur.



Death or catastrophic harm COULD occur.



Machine or property damage may occur.

Basic Machine Safety

- 1. Owner's Manual:** All machinery and machining equipment presents serious injury hazards to untrained users. To reduce the risk of injury, anyone who uses THIS item MUST read and understand this entire manual before starting.
- 2. Personal Protective Equipment:** Operating or servicing this item may expose the user to flying debris, dust, smoke, dangerous chemicals, or loud noises. These hazards can result in eye injury, blindness, long-term respiratory damage, poisoning, cancer, reproductive harm or hearing loss. Reduce your risks from these hazards by wearing approved eye protection, respirator, gloves, or hearing protection.
- 3. Trained/Supervised Operators Only:** Untrained users can seriously injure themselves or bystanders. Only allow trained and properly supervised personnel to operate this item. Make sure safe operation instructions are clearly understood. If electrically powered, use padlocks and master switches, and remove start switch keys to prevent unauthorized use or accidental starting.
- 4. Guards/Covers:** Accidental contact with moving parts during operation may cause severe entanglement, impact, cutting, or crushing injuries. Reduce this risk by keeping any included guards/covers/doors installed, fully functional, and positioned for maximum protection.

- 5. Entanglement:** Loose clothing, gloves, neckties, jewelry or long hair may get caught in moving parts, causing entanglement, amputation, crushing, or strangulation. Reduce this risk by removing/securing these items so they cannot contact moving parts.
- 6. Mental Alertness:** Operating this item with reduced mental alertness increases the risk of accidental injury. Do not let a temporary influence or distraction lead to a permanent disability! Never operate when under the influence of drugs/alcohol, when tired, or otherwise distracted.
- 7. Safe Environment:** Operating electrically powered equipment in a wet environment may result in electrocution; operating near highly flammable materials may result in a fire or explosion. Only operate this item in a dry location that is free from flammable materials.
- 8. Electrical Connection:** With electrically powered equipment, improper connections to the power source may result in electrocution or fire. Always adhere to all electrical requirements and applicable codes when connecting to the power source. Have all work inspected by a qualified electrician to minimize risk.
- 9. Disconnect Power:** Adjusting or servicing electrically powered equipment while it is connected to the power source greatly increases the risk of injury from accidental startup. Always disconnect power **BEFORE** any service or adjustments, including changing blades or other tooling.
- 10. Secure Workpiece/Tooling:** Loose workpieces, cutting tools, or rotating spindles can become dangerous projectiles if not secured or if they hit another object during operation. Reduce the risk of this hazard by verifying that all fastening devices are properly secured and items attached to spindles have enough clearance to safely rotate.
- 11. Chuck Keys or Adjusting Tools:** Tools used to adjust spindles, chucks, or any moving/rotating parts will become dangerous projectiles if left in place when the machine is started. Reduce this risk by developing the habit of always removing these tools immediately after using them.
- 12. Work Area:** Clutter and dark shadows increase the risks of accidental injury. Only operate this item in a clean, non-glaring, and well-lighted work area.
- 13. Properly Functioning Equipment:** Poorly maintained, damaged, or malfunctioning equipment has higher risks of causing serious personal injury compared to those that are properly maintained. To reduce this risk, always maintain this item to the highest standards and promptly repair/service a damaged or malfunctioning component. Always follow the maintenance instructions included in this documentation.
- 14. Unattended Operation:** Electrically powered equipment that is left unattended while running cannot be controlled and is dangerous to bystanders. Always turn the power **OFF** before walking away.
- 15. Health Hazards:** Certain cutting fluids and lubricants, or dust/smoke created when cutting, may contain chemicals known to the State of California to cause cancer, respiratory problems, birth defects, or other reproductive harm. Minimize exposure to these chemicals by wearing approved personal protective equipment and operating in a well ventilated area.
- 16. Difficult Operations:** Attempting difficult operations with which you are unfamiliar increases the risk of injury. If you experience difficulties performing the intended operation, **STOP!** Seek an alternative method to accomplish the same task, ask a qualified expert how the operation should be performed, or contact our Technical Support for assistance.

Additional Metal Cutting Bandsaw Safety

- 1. Blade Condition:** Do not operate with a dull, cracked or badly worn blade—they can break during use or greatly decrease cutting performance. Inspect blades for cracks and missing teeth before each use.
- 2. Blade Replacement:** Wear gloves to protect hands and safety glasses to protect eyes when replacing the blade. When replacing blades, make sure teeth face forward and down toward the table in the direction of blade travel.
- 3. Workpiece Handling:** Your hands can be cut or drawn into the blade during operation if the workpiece moves unexpectedly. Always keep your hands a safe distance away from the moving blade.
- 4. Welding And Grinding Safety:** The welding station can be hazardous if used incorrectly and without proper personal protection. Always wear welding-approved gloves, eye protection, and clothing when welding blades. Touching any metal parts of the blade, welder, or machine when activating the welder could lead to electrocution. Welding near flammables could cause a fire.
- 5. Hot Surfaces:** Be aware that touching hot workpieces or chips after welding, grinding, or cutting can cause burns.
- 6. Cutting Fluid Safety:** This machine is designed for dry cutting operations. Flood-type cutting fluid setups should not be used because the machine is not waterproof.
- 7. Magnesium Fire Hazard:** Use EXTREME CAUTION if cutting magnesium. Using the wrong cutting fluid or overheating the material could lead to an extremely hot fire that is difficult to extinguish. Additionally, do not allow magnesium swarf or dust to pile up around the machine and only dispose of the waste using approved methods.
- 8. Entanglement Hazards:** Always keep the blade guard correctly positioned and wheel doors closed and secured when bandsaw is in operation. Loose clothing, jewelry, long hair and work gloves can be drawn into working parts.
- 9. Maintenance/Service:** All inspections, adjustments, and maintenance are to be done with the power **OFF** and the plug pulled from the outlet. Wait for all moving parts to come to a complete stop.
- 10. Unstable Workpieces:** Workpieces that cannot be supported or stabilized without a vise or jig should not be cut on a vertical metal-cutting bandsaw, because they can unexpectedly move while cutting and draw the operator's hands into the blade causing serious personal injury. Examples are chains, cables, round or oblong-shaped workpieces, workpieces with internal or built-in moving or rotations parts, etc.
- 11. Clearing Chips:** Metal chips can easily cut skin—even through a piece of cloth. Avoid clearing chips by hand or with a rag. Use a brush or vacuum to clear metal chips.

Preparation Overview

The purpose of the preparation section is to help you prepare your machine for operation. The list below outlines the basic process. Specific steps for each of these points will be covered in detail later in this section.

The typical preparation process is as follows:

1. Unpack the machine and inventory the contents of the box/crate.
2. Clean the machine and its components.
3. Identify an acceptable location for the machine and move it to that location.
4. Level the machine and either bolt it to the floor or place it on mounts.
5. Assemble the loose components and make any necessary adjustments or inspections to ensure the machine is ready for operation.
6. Connect the machine to the power source.
7. Test run the machine to make sure it functions properly and is ready for operation.

Things You'll Need

During the setup process, operation, and maintenance of your machine, you'll need the following items:

For Lifting

- A forklift or other power lifting device rated for the weight of the machine.
- Lifting Strap or chain w/safety hook (rated for at least 1000 lbs.)

For Power Connection

- A qualified electrician to ensure a safe and code-compliant connection to the power source. (Refer to **Page 20** for details.)

For Assembly

- Cotton Rags
- Mineral Spirits
- Safety Glasses
- Oil Can with any General Machine Oil
- Blade Tension Tool
- Grease Gun with any API GL 2 Grease
- Stiff Grease Brush
- Phillips Screwdriver #2
- Floor Mounting Hardware As Needed
- Hex Wrench 5mm
- Hex Wrench 6mm
- Combo Wrench 1/2" or Ratchet and 1/2" Socket

Power Supply Requirements

Availability

Before installing the machine, consider the availability and proximity of the required power supply circuit. If an existing circuit does not meet the requirements for this machine, a new circuit must be installed.

To minimize the risk of electrocution, fire, or equipment damage, installation work and electrical wiring must be done by a qualified electrician in accordance with all applicable codes and standards.



! WARNING
Electrocution or fire may occur if machine is not correctly grounded and attached to the power supply. Use a qualified electrician to ensure a safe power connection.

Full-Load Current Rating

The full-load current rating is the amperage a machine draws at 100% of the rated output power. On machines with multiple motors, this is the amperage drawn by the largest motor or sum of all motors and electrical devices that might operate at one time during normal operations.

- Model SB1040 Full-Load Rating 110V... 12.6A**
- Model SB1040 Full-Load Rating 220V..... 6.6A**
- Model SB1041 Full-Load Rating 220V.... 3.6A**

The full-load current is not the maximum amount of amps that the machine will draw. If the machine is overloaded, it will draw additional amps beyond the full-load rating.

If the machine is overloaded for a sufficient length of time, damage, overheating, or fire may result—especially if connected to an undersized circuit. To reduce the risk of these hazards, avoid overloading the machine during operation and make sure it is connected to a power supply circuit that meets the requirements in the following section.

Circuit Information

A power supply circuit includes all electrical equipment between the main breaker box or fuse panel in your building and the incoming power connections inside the machine. This circuit must be safely sized to handle the full-load current that may be drawn from the machine for an extended period of time.

! CAUTION

For your own safety and protection of property, consult a qualified electrician if you are unsure about wiring practices or electrical codes in your area.

Note: The circuit requirements listed in this manual apply to a dedicated circuit—where only one machine will be running at a time. If this machine will be connected to a shared circuit where multiple machines will be running at the same time, consult a qualified electrician to ensure that the circuit is properly sized for safe operation.

SB1040 Circuit Requirements at 110V

This machine is prewired to operate on a 110V power supply circuit that has a verified ground and meets the following requirements:

- Nominal Voltage 110V**
- Cycle 60 Hz**
- Phase Single-Phase**
- Circuit Rating..... 20 Amps**
- Plug/Receptacle Type NEMA 5-15**

SB1040 Circuit Requirements at 220V

This machine can be modified to operate on a 220V power supply circuit that has a verified ground and meets the following requirements:

- Nominal Voltage 220V**
- Cycle 60 Hz**
- Phase Single-Phase**
- Circuit Rating..... 15 Amps**
- Plug/Receptacle Type NEMA 6-15**

SB1041 Circuit Requirements

This machine is prewired to operate on a 220V power supply circuit that has a verified ground and meets the following requirements:

- Nominal Voltage220V
- Cycle60 Hz
- Phase3-Phase
- Circuit Rating..... 15 Amps
- Plug/Receptacle TypeHardwire

Grounding Requirements

In the event of certain types of malfunctions or breakdowns, grounding provides a path of least resistance for electric current—in order to reduce the risk of electric shock.

For 110V Connection (SB1040 Prewired)

This machine is equipped with a power cord that has an equipment-grounding wire and a grounding plug (similar to the figure below). The plug must only be inserted into a matching receptacle (outlet) that is properly installed and grounded in accordance with all local codes and ordinances.

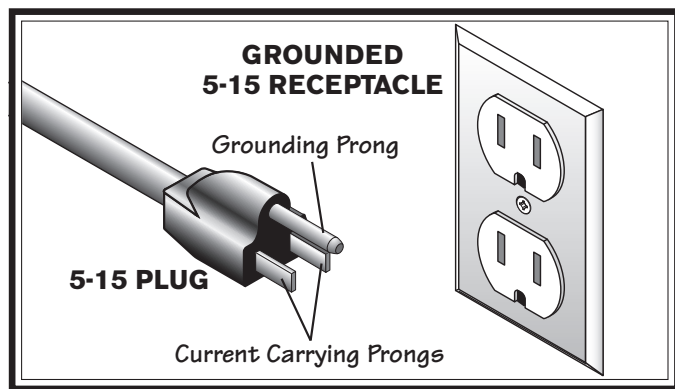

Figure 1. NEMA 5-15 plug and receptacle.

For 220V 1-Phase Connection (SB1040)

Use the plug type listed in the **Circuit Requirements** for this voltage. The listed plug (similar to the figure below) has an equipment-grounding wire to safely ground the machine. The plug must only be inserted into a matching receptacle (outlet) that is properly installed and grounded in accordance with all local codes and ordinances.

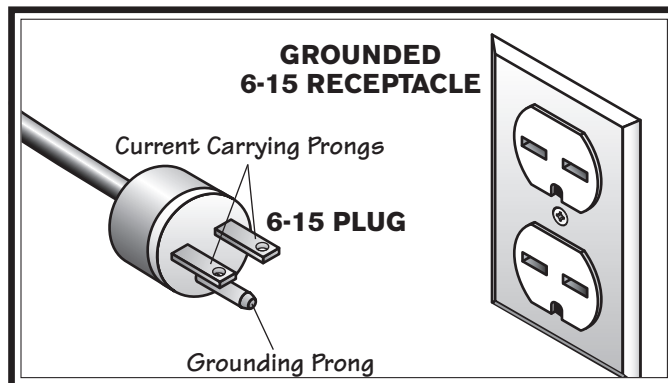

Figure 2. NEMA 6-15 plug and receptacle.

For 220V 3-Phase Connection (SB1041)

Power supply connections that are hardwired to the power source must be connected to a grounded metal permanent wiring system, or to a system having an equipment-grounding conductor.

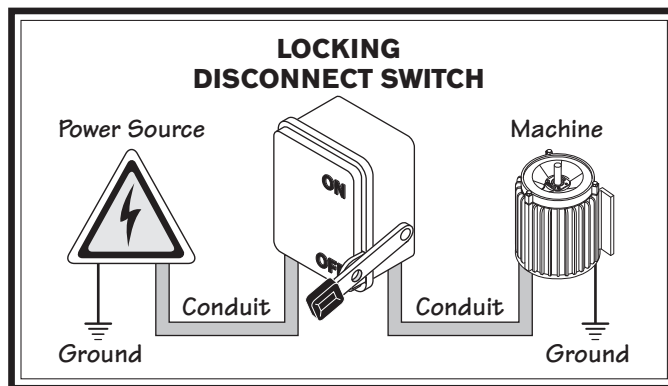

Figure 3. Typical hardwire setup.

⚠️ WARNING

Serious injury could occur if you connect the machine to power before completing the setup process. **DO NOT** connect to power until instructed later in this manual.

Improper connection of the equipment-grounding wire can result in a risk of electric shock. The wire with green insulation (with or without yellow stripes) is the equipment-grounding wire. If repair or replacement of the power cord or plug is necessary, do not connect the equipment-grounding wire to a live (current carrying) terminal.

Check with a qualified electrician or service personnel if you do not understand these grounding requirements, or if you are in doubt about whether the tool is properly grounded.

If you ever notice that a cord or plug is damaged or worn, disconnect it from power, and immediately replace it with a new one.

Extension Cords

We do not recommend using an extension cord with this machine. If you must use one, only use it if absolutely necessary and only on a temporary basis.

Extension cords cause voltage drop, which may damage electrical components and shorten motor life. Voltage drop increases as the extension cord size gets longer and the gauge size gets smaller (higher gauge numbers indicate smaller sizes).

Any extension cord used with this machine must contain a ground wire, match the required plug and receptacle listed in the **Circuit Requirements** for the applicable voltage, and meet the following requirements:

Minimum Gauge Size.....12 AWG
Maximum Length (Shorter is Better)50 ft.

Unpacking

This item was carefully packaged to prevent damage during transport. If you discover any damage, please immediately call Customer Service at (360) 734-1540 for advice. You may need to file a freight claim, so save the containers and all packing materials for possible inspection by the carrier or its agent.

Inventory

Main Inventory: (Figure 4)		Qty
A.	Machine	1
Optional Inventory: (Figure 5)		Qty
B.	Circle Cutting Jig.....	1
C.	Cap Screws M8-1.25 x 25.....	2
D.	Lock Washers 8mm.....	2

The circle cutting jig and its mounting hardware are not required for operation. Their installation and use is covered in **Circle Cutting Jig** on **Page 36**.



Figure 4. Main inventory.

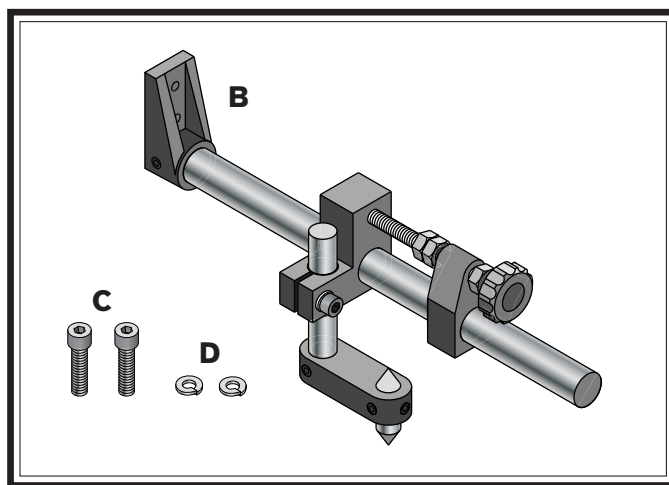

Figure 5. Optional inventory.

Cleaning & Protecting

The unpainted surfaces are coated at the factory with a heavy-duty rust preventative that prevents corrosion during shipment and storage. The benefit of this rust preventative is that it works very well. The downside is that it can be time-consuming to thoroughly remove.

Be patient and do a careful job when cleaning and removing the rust preventative. The time you spend doing this will reward you with smooth-sliding parts and a better appreciation for the proper care of the unpainted surfaces.

Although there are many ways to successfully remove the rust preventative, we have cleaned thousands of machines and found the following process to be the best balance between efficiency and minimized exposure to toxic fumes or chemicals.

Before cleaning, gather the following:

- Disposable rags
- Cleaner/degreaser (certain citrus-based degreasers work extremely well and they have non-toxic fumes)
- Safety glasses & disposable gloves

Note: Automotive degreasers, mineral spirits, or WD•40 can be used to remove rust preventative. Before using these products, though, test them on an inconspicuous area of a painted area to make sure they will not damage it.

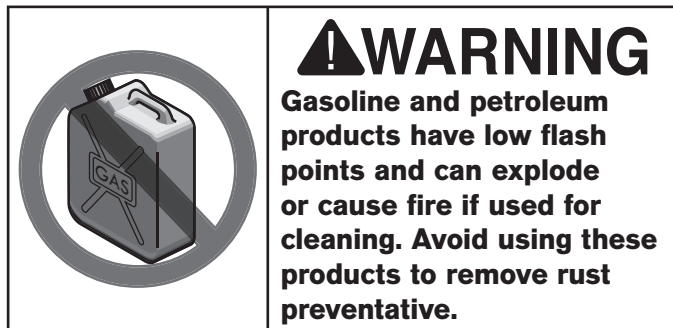

CAUTION

Many cleaning solvents are toxic if inhaled. Minimize your risk by only using these products in a well ventilated area.

NOTICE

Avoid chlorine-based solvents, such as acetone or brake parts cleaner that may damage painted surfaces. Always follow the manufacturer's instructions when using any type of cleaning product.

Basic steps for removing rust preventative:

1. Put on safety glasses and disposable gloves.
2. Coat all surfaces that have rust preventative with a liberal amount of your cleaner or degreaser and let them soak for a few minutes.
3. Wipe off the surfaces. If your cleaner or degreaser is effective, the rust preventative will wipe off easily.

Note: To clean off thick coats of rust preventative on flat surfaces, such as beds or tables, use a PLASTIC paint scraper to scrape off the majority of the coating before wiping it off with your rag. (Do not use a metal scraper or it may scratch the surface.)

4. Repeat **Steps 2–3** as necessary until clean, then coat all unpainted surfaces with a quality metal protectant or light oil to prevent rust.

Location

Physical Environment

The physical environment where your machine is operated is important for safe operation and longevity of parts. For best results, operate this machine in a dry environment that is free from excessive moisture, hazardous or flammable chemicals, airborne abrasives, or extreme conditions. Extreme conditions for this type of machinery are generally those where the ambient temperature is outside the range of 41°–104°F; the relative humidity is outside the range of 20–95% (non-condensing); or the environment is subject to vibration, shocks, or bumps.

Electrical Installation

Place this machine near an existing power source. Make sure all power cords are protected from traffic, material handling, moisture, chemicals, or other hazards. Make sure to leave access to a means of disconnecting the power source or engaging a lockout/tagout device.

Lighting

Lighting around the machine must be adequate enough that operations can be performed safely. Shadows, glare, or strobe effects that may distract or impede the operator must be eliminated.

Weight Load

Refer to the **Machine Specifications** for the weight of your machine. Make sure that the surface upon which the machine is placed will bear the weight of the machine, additional equipment that may be installed on the machine, and the heaviest workpiece that will be used. Additionally, consider the weight of the operator and any dynamic loading that may occur when operating the machine.

Space Allocation

Consider the largest size of workpiece that will be processed through this machine and provide enough space around the machine for adequate operator material handling or the installation of auxiliary equipment. With permanent installations, leave enough space around the machine to open or remove doors/covers as required by the maintenance and service described in this manual.

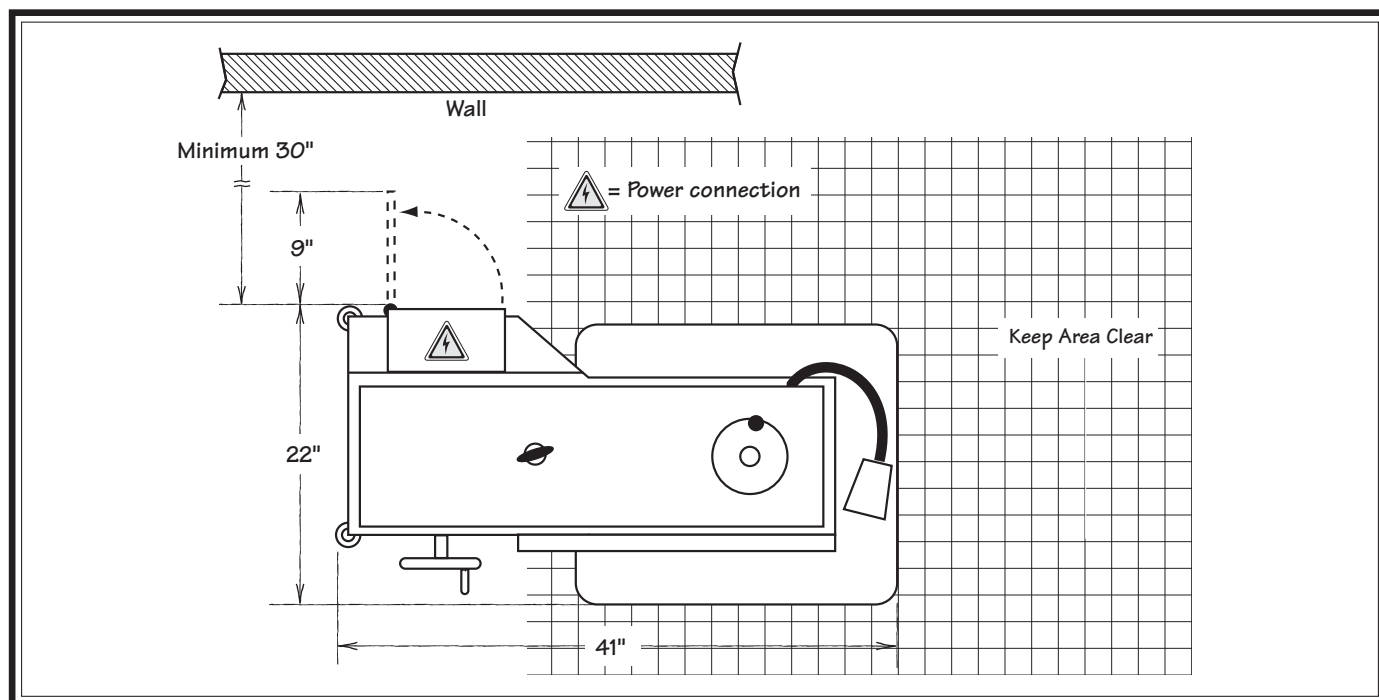
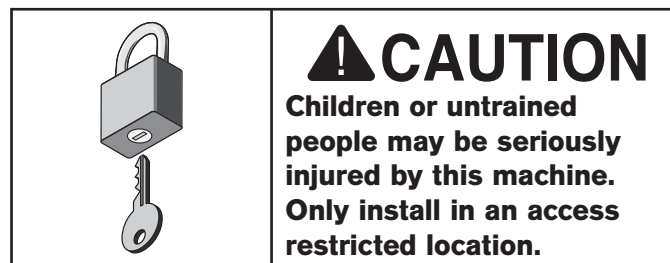

Lifting & Moving

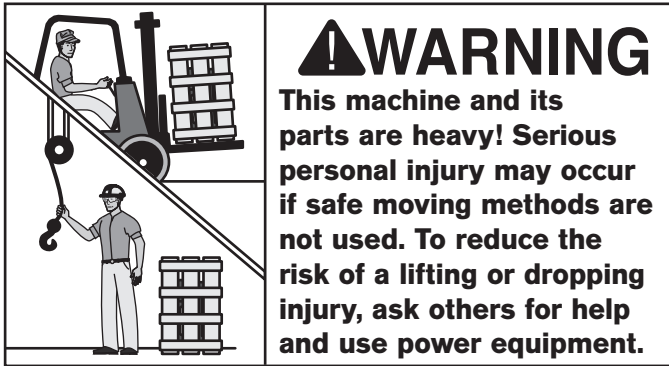

Make sure the lifting eye shown in **Figure 7** is completely threaded into the headstock, then lift the machine off the pallet and onto a suitable location using the lifting eye.



Figure 7. Lifting location.

Securing to Floor

Generally, you can either bolt your machine to the floor or mount it on machine mounts. Although not required, we recommend that you secure the machine to the floor and level it while doing so. Because this is an optional step and floor materials may vary, hardware for securing the machine to the floor is not included.

NOTICE

We strongly recommend securing your machine to the floor if it is hardwired to the power source. Consult with your electrician to ensure compliance with local codes.

Bolting to Concrete Floors

Lag screws and anchors, or anchor studs (**below**), are two popular methods for securing machinery to a concrete floor. We suggest you research the many options and methods for securing your machine and choose the best one for your specific application.

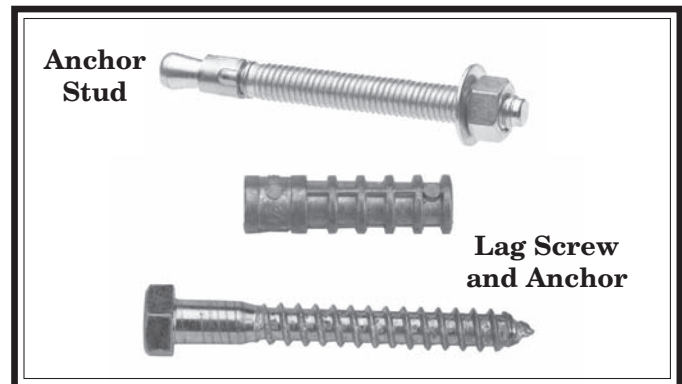

Figure 8. Common types of fasteners for securing machinery to concrete floors.

Machine Mounts

Machine mounts are rubber pads mounted to a threaded stud, which can be fastened to the bottom of the machine.

Machine mounts offer certain advantages such as ease of installation, vibration dampening, and easy leveling. They also make it easier to relocate the machine later on.

The disadvantage of machine mounts is that the machine can shift or move over time. For this reason, electrical codes may limit their use if the machine is hardwired to the power source. Also, mounts may reduce the total surface area of machine-to-floor contact, depending on the design of the machine.



Figure 9. Typical machine mount.

Assembly

This machine comes pre-assembled from the factory. However, tension has been removed from the blade for shipping purposes. Before operating the machine for the first time, you **MUST** make sure the blade is properly tensioned. Refer to the **Blade Tensioning** procedure on **Page 27** for instructions about how to do this.

Initial Lubrication

Your machine was lubricated at the factory, but we strongly recommend that you inspect all lubrication points yourself and provide additional lubrication if necessary. Refer to **Lubrication** on **Page 38** for specific details.

Power Connection

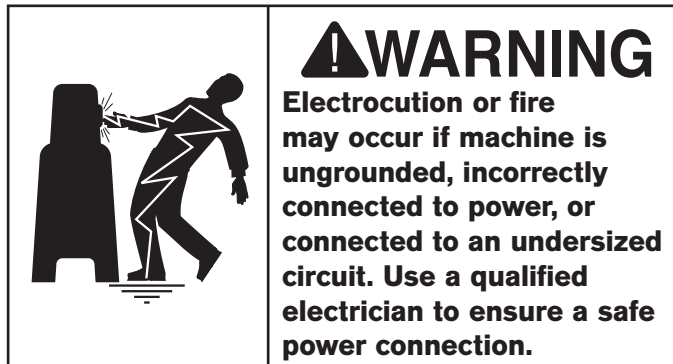

Once your machine is set up and assembled as previously described in this manual, it is ready to be connected to the power source.

Use the information in this section to determine the power source requirements needed to operate this machine. If your existing power source does not meet the stated requirements, consult with a qualified electrician about running a new circuit.

Note About Extension Cords: Using an incorrectly sized extension cord may decrease the life of electrical components on your machine.

Note About 3-Phase Power (SB1041 Only): DO NOT use a static phase converter to create 3-phase power—it can quickly decrease the life of electrical components on your machine. If you must use a phase converter, only use a rotary phase converter and connect the wild wire to the correct power connection terminal, shown in the wiring diagram on **Page 53**.

220V Conversion for SB1040

Wiring diagrams are provided on **Pages 50 and 52** in this manual, showing the Model SB1040 wired for both 110V and 220V. Refer to these diagrams when following this procedure.

To convert the Model SB1040 to operate on 220V:

1. DISCONNECT BANDSAW FROM POWER!
2. Rewire the motor for 220V, as shown in the diagram on the inside of the motor junction box. If there is not a diagram in the junction box, use the motor wiring diagram in this manual (see **Page 52**).

3. Locate the power transformer in the electrical panel (see **Figure 56 on Page 54**). Remove the wire attached to the 110V terminal and connect it to the 220V terminal.
4. Turn the dial on the overload relay (see **Figure 56 on Page 54**) from 14A for 110V to 7A for 220V.
5. Locate the welding transformer in the control panel (see **Figure 55 on Page 54**). Remove the wire connected to the #2 terminal and move it to the #5 terminal; remove the wire connected to the #4 terminal and move it to the #7 terminal. The machine is now wired for 220V.

Correcting Phase Polarity (SB1041 Only)

This sub-section is only provided for troubleshooting 3-phase power connections. If you discover during the test run that the machine will not operate, or that the motor runs backwards, the power source connection may be wired "out of phase," meaning that the polarity is incorrect as wired. Without test equipment to determine polarity, this is a common situation with 3-phase power.

To correct the polarity of a power source connection:

1. DISCONNECT MACHINE FROM POWER!
2. Open the electrical box and disconnect the incoming power cord R and T wires from the main terminal bar in the upper right corner of the electrical panel (see **Page 53**).
3. Connect the R wire to the terminal where the T wire was connected originally.
4. Connect the T wire to the terminal where the R wire was connected originally.
5. Close and latch the electrical box, and reconnect the machine to the power source.
6. Follow the **Test Run on Page 21** to ensure that the machine functions properly.

Test Run

After all preparation steps have been completed, the machine and its safety features must be tested to ensure correct operation. If you discover a problem with the operation of the machine or its safety components, do not operate it further until you have resolved the problem.

Note: Refer to **Troubleshooting** on **Page 44** for solutions to common problems that occur with all metal bandsaws. If you need additional help, contact our Tech Support at (360) 734-1540.

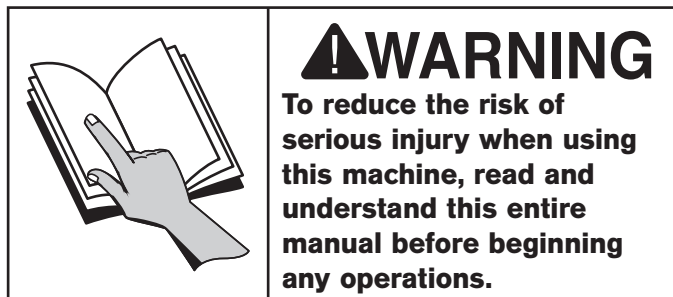

To test run your machine:

1. Read and follow the safety instructions at the beginning of the manual, take required safety precautions, and make sure the machine is set up and adjusted properly
2. Clear away all tools and objects used during assembly and preparation.
3. Make sure the blade is properly tensioned and the blade guides are positioned correctly (for detailed instructions, refer to **Blade Tensioning** on **Page 27**, and **Adjusting Blade Guides** on **Page 30**).
4. Connect the machine to the power source.
5. Push the ON button. The green motor light will illuminate and the motor will start.
6. Verify that the machine is operating correctly. When operating correctly, the machine runs smoothly with little or no vibration or rubbing noises.

Note: For three-phase models, verify that the blade is moving downward toward the table. If so, the motor is running in the correct direction. Proceed to **Step 7**.

- If the blade is moving in the upward direction out of the table, stop the machine immediately. It is likely wired "out of phase." To correct this problem, refer to **Correcting Phase Polarity** on **Page 20**.
7. Adjust the blade speed through the full range of operation. The speed should change as you make the adjustments.
 8. Press the STOP button, the green motor light will go out, and the bandsaw will stop.
 9. Turn the work lamp and the welding lamp **ON** and **OFF**.
 10. Turn the grinder **ON** and **OFF**.

Inspections & Adjustments

The following list of adjustments were performed at the factory before your machine was shipped:

- **Blade Guide Adjustment**Page 30
- **V-Belt Adjustment**Page 39
- **Table Calibration**Page 41
- **Blade Tracking**.....Page 41
- **Guide Post Alignment**Page 42

Be aware that machine components can shift during the shipping process. Pay careful attention to these adjustments as you test run your machine. If you find that the adjustments are not set according to the procedures in this manual or they do not suit your personal preferences, re-adjust them.

Operation Overview

The purpose of this overview is to provide the novice machine operator with a basic understanding of how the machine is used during operation, so they can more easily understand the controls discussed later in this manual.

Note: Due to the generic nature of this overview, it is not intended to be an instructional guide for performing actual machine operations. To learn more about specific operations and machining techniques, seek training from people experienced with this type of machine, and do additional research outside of this manual by reading "how-to" books, trade magazines, or websites.

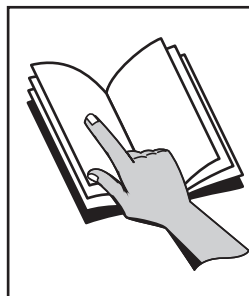

! WARNING

To reduce the risk of serious injury when using this machine, read and understand this entire manual before beginning any operations.

To complete a typical operation, the operator does the following:

1. Examines the workpiece to make sure it is suitable for cutting.
2. Checks to make sure blade tension is correct, and the blade guides are positioned correctly.
3. Marks the cut line on the workpiece.

! WARNING

Workpieces that cannot be stabilized from unexpected movement should not be cut with a vertical metal bandsaw due to the increased risk of the operator's hands slipping into the blade. Examples are chains, cables, balls, or workpieces with built-in moving parts.

4. Adjusts the upper blade guide height to approximately $\frac{1}{8}$ "– $\frac{1}{4}$ " above the workpiece for maximum blade support.
5. Puts on safety glasses, and rolls up sleeves or secures any clothing or hair that could get entangled with moving parts.

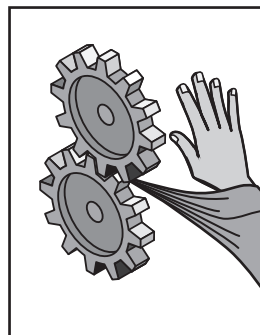

! WARNING

Loose hair, clothing, or jewelry could get caught in machinery and cause serious personal injury. Keep these items away from moving parts at all times to reduce this risk.



! WARNING

During operation, small metal chips may become airborne, leading to serious eye injury. Wear safety glasses to reduce this risk.

6. Turns the bandsaw **ON**, and adjusts blade speed for the type of material being cut.
7. Presses the workpiece against the blade, using light and even pressure and following the cut line with the blade.

Depending on the workpiece material, the operator may squirt a small amount of cutting fluid at the cutting area to keep it from overheating and smoking.

8. Turns the bandsaw **OFF**.

Controls

Refer to **Figures 10–12** and the following descriptions to become familiar with the basic controls of this machine.

- A. Motor Light:** Lights when the ON button is pressed and there is power to the machine.
- B. ON Button:** Turns the main motor *ON*.
- C. OFF Button:** Turns the main motor *OFF*.
- D. Clamping Pressure Dial:** Sets the correct amount of pressure for pressing the ends of the blades against each other when welding.
- E. Welding Clamp:** Holds a segment of the bandsaw blade to be welded.
- F. Lock Lever:** Secures bandsaw blade for welding operations when rotated up.
- G. Grinder Switch:** Turns grinder *ON/OFF*.
- H. Shear Lever:** Cuts the bandsaw blade.
- I. Welding Button:** Activates the process of fusing the two blades together.
- J. Annealing Button:** Heats up the blade joint, then allows it to cool in a gradual manner to establish weld strength.
- K. Blade Speed Display:** Displays the current blade speed in Feet Per Minute (FPM).

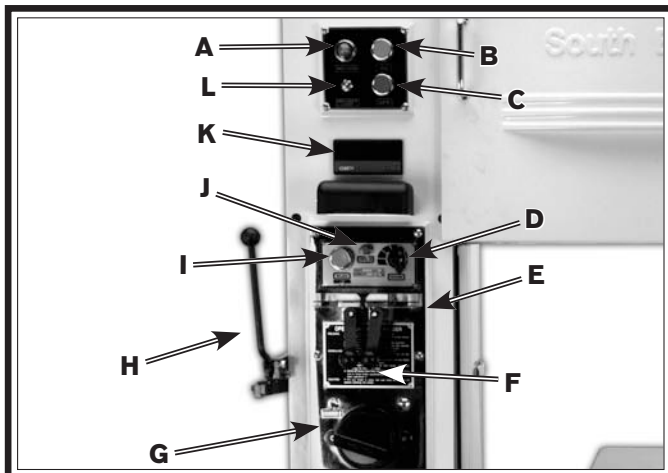

Figure 10. Front controls.

- L. Welder's Lamp Switch:** Illuminates welding station when turned *ON*.
- M. Variable Speed Handwheel:** Adjusts blade speed from 88 to 384 FPM.



Figure 11. Variable speed handwheel.

- N. Blade Tensioning Handwheel:** Increases or decreases blade tension when rotated.
- O. Guide Post Elevation Knob:** Raises or lowers the guide post and upper blade guide assembly.
- P. Guide Post Lock Knob:** Secures the guide post and upper blade guide assembly in position.

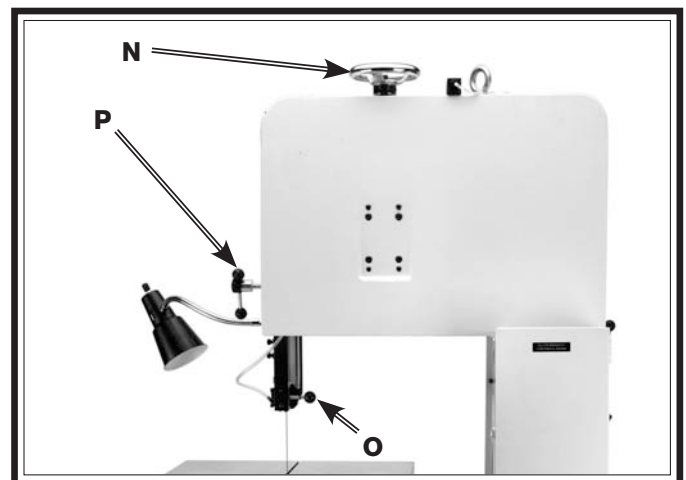

Figure 12. Blade controls.

Blade Selection

Selecting the right blade for the cut requires a knowledge of various blade characteristics.

Blade Terminology

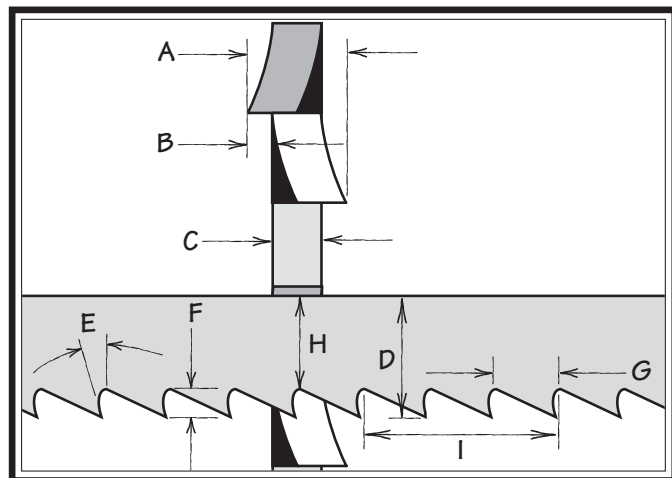

Figure 13. Bandsaw blade terminology.

- A. Kerf:** The amount of material removed by the blade during cutting.
- B. Tooth Set:** The amount each tooth is bent left or right from the blade.
- C. Gauge:** The thickness of the blade.
- D. Blade Width:** The widest point of the blade measured from the tip of the tooth to the back edge of the blade.
- E. Tooth Rake:** The angle of the tooth face from a line perpendicular to the length of the blade.
- F. Gullet Depth:** The distance from the tooth tip to the bottom of the curved area (gullet).
- G. Tooth Pitch:** The distance between tooth tips.
- H. Blade Back:** The distance between the bottom of the gullet and the back edge of the blade.
- I. Blade Pitch or TPI:** The number of teeth per inch measured from gullet to gullet.

Blade Length

Measured by the blade circumference, blade lengths are usually unique to the brand of your bandsaw and the distance between the wheels.

Model	Blade Length Range
SB1040/SB1041.....	139 ³ / ₈ "–140 ¹ / ₂ "

Blade Width

Measured from the back of the blade to the tip of the blade tooth (the widest point), blade width is often the first consideration given to blade selection. Blade width dictates the largest and smallest curve that can be cut, as well as how accurately it can cut a straight line—generally the wider the blade, the straighter it will cut.

Model	Blade Width Range
SB1040/SB1041.....	¹ / ₈ "– ⁵ / ₈ "

Always pick the blade width that best suits your operation.

Curve Cutting: Use the chart in **Figure 14** to choose the correct blade for curve cutting. Determine the smallest radius curve that will be cut on your workpiece and use the corresponding blade width.

The list below shows the minimum radius that can be cut by each blade width.

Width	Radius
¹ / ₈ "	¹ / ₈ "
³ / ₁₆ "	³ / ₈ "
¹ / ₄ "	⁵ / ₈ "
³ / ₈ "	1 ¹ / ₄ "
¹ / ₂ "	2 ¹ / ₂ "
⁵ / ₈ "	4"

Figure 14. Blade width radii.

Tooth Set

Three common tooth sets are alternate, wavy, and raker (see **Figure 15**). Each removes material in a different manner to make the kerf in the workpiece.

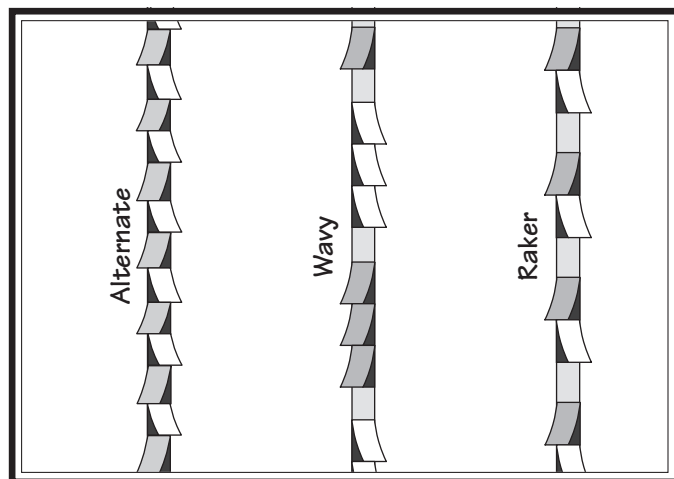

Figure 15. Bandsaw blade tooth sets.

Alternate: An all-purpose arrangement of bending the teeth evenly left and right of the blade. Generally used for milder metals.

Wavy: Generally three or more teeth in a group that are bent one way, followed by a non-set tooth, and then a group bent the other way. Recommended for straight cuts in thin metals or thin-wall tubing.

Raker: Three teeth in a recurring group—one bent left, next one bent right, and then a non-set tooth. The raker set is ideal for most contour cuts.

Tooth Type

The most common tooth types are described below and illustrated in **Figure 16**.

Standard or Raker: Equally spaced teeth set at a "0" rake angle. Recommended for all purpose use.

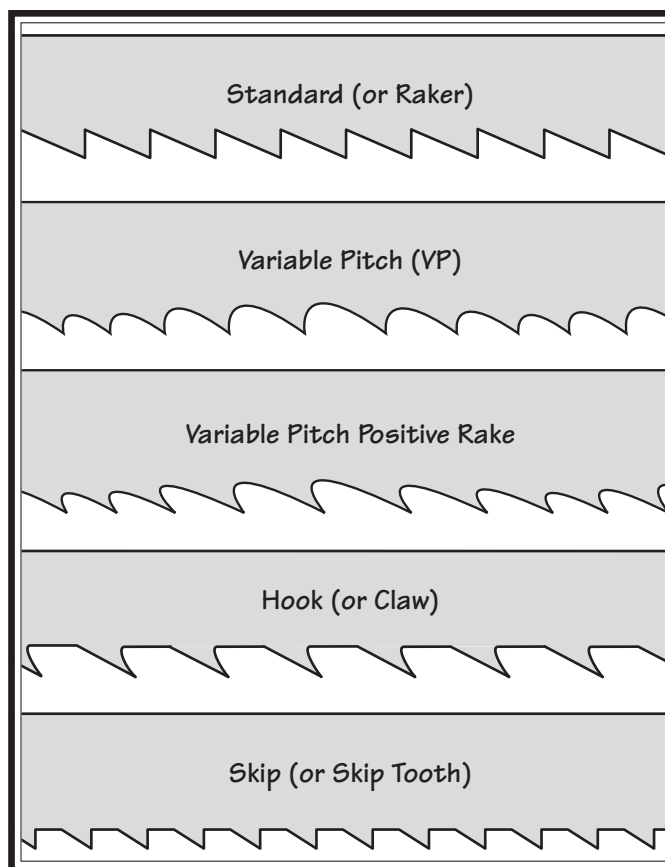

Figure 16. Bandsaw blade tooth types.

Variable Pitch (VP): Varying gullet depth and tooth spacing, a "0" rake angle, excellent chip removing capacity, and smooth cutting.

Variable Pitch with Positive Rake: Varying gullet depth and tooth spacing, a positive rake angle, better chip formation, and aggressive cutting.

Hook or Claw: Wide gullets (round or flat), equally spaced teeth, positive rake angle, and fast cut with good surface finish.

Skip or Skip Tooth: Wide, flat gullets, a "0" rake angle, equally spaced teeth, and recommended for non-ferrous materials.

Blade Pitch (TPI)

The chart below is a basic starting point for choosing teeth per inch (TPI) for variable pitch blades and standard raker set bi-metal blades/HSS blades. However, for exact specifications of bandsaw blades that are correct for your operation, contact the blade manufacturer.

To select the correct blade pitch:

1. Measure the material thickness. This measurement is the length of cut taken from where the tooth enters the workpiece, sweeps through, and exits the workpiece.
2. Refer to the "Material Width/Diameter" row of the blade selection chart in **Figure 17**, and read across to find the workpiece thickness you need to cut.

3. Refer to the "Material Shapes" row and find the shape of the material to be cut.
4. In the applicable row, read across to the right and find the box where the row and column intersect. Listed in the box is the minimum TPI recommended for the variable tooth pitch blades.
5. The "Cutting Speed Rate Recommendation" section of the chart offers guidelines for various metals, given in feet per minute (FPM). Choose the speed closest to the number shown in the chart.

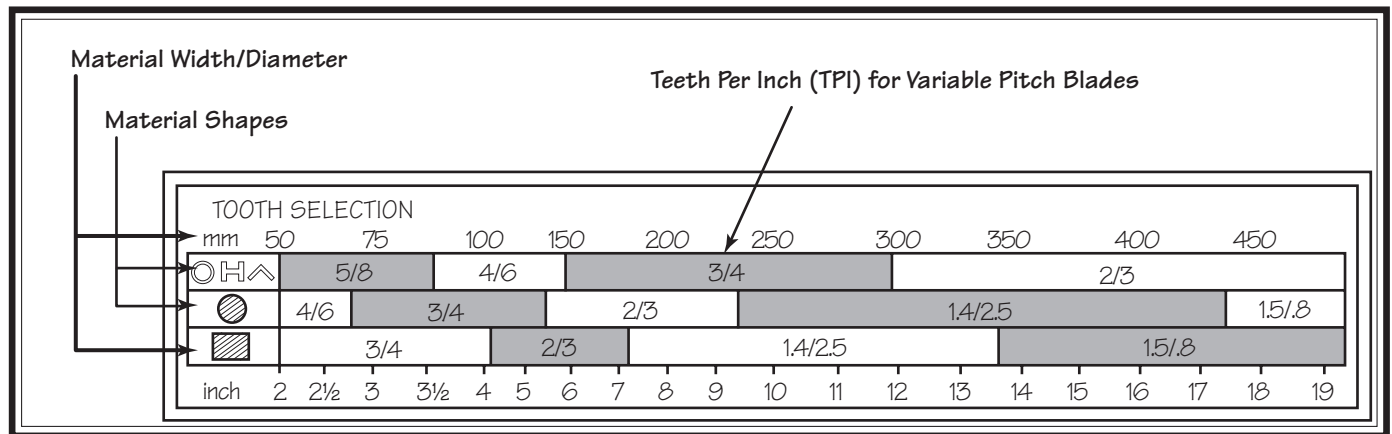
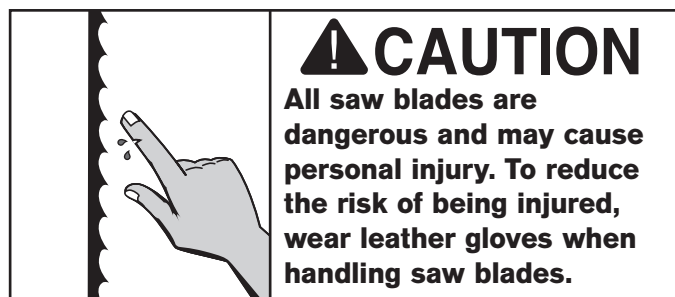
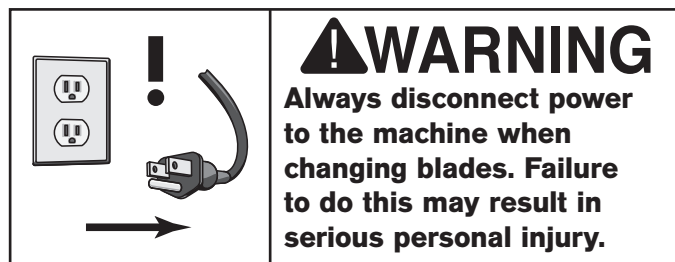

Figure 17. General guidelines for blade selection and speed chart.

Blade Changes



To replace the blade:

1. DISCONNECT BANDSAW FROM POWER!
2. Open the upper and lower wheel doors, release tension on the blade, and move the blade guides away from the blade.
3. Put on heavy gloves, then slide the blade off the upper and lower wheels, around the blade post, and through the table slit.
4. Install a new blade in reverse order.
5. Position the back edge of the blade so that it is next to, but not against, the flange of the top wheel (see **Figure 18**).

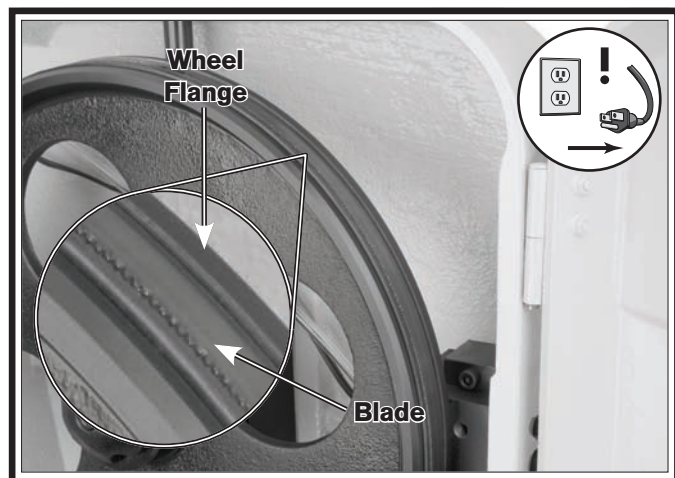

Figure 18. Back edge of blade next to wheel flange.

Note: Excessive blade contact with the wheel flange during operation could lead to blade and wheel damage.

6. Re-tension the blade (refer to the following **Blade Tensioning** section).
7. Rotate the top wheel clockwise by hand several times to make sure the blade tracks evenly without wandering across the wheel surface.

Note: If the blade wanders across the wheel and away from the flange, the wheel alignment may need to be adjusted. Refer to **Blade Tracking** on **Page 41** for detailed instructions.

8. Adjust the upper and lower blade guides (refer to **Adjusting Blade Guides** on **Page 30**).
9. Close and secure the upper and lower wheel doors.

Blade Tension

Proper blade tension reduces the risk of blade breakage and improves cutting performance.

NOTICE

To prolong blade life, release the tension on the blade if the machine will be idle for an extended period of time.

To correctly tension the blade:

1. DISCONNECT BANDSAW FROM POWER!
2. Turn the blade tension handwheel until you feel an moderate amount of resistance and the handwheel wants to stop. Then turn the handwheel an additional $\frac{1}{2}$ turn.

Blade Breakage

Many conditions may cause a bandsaw blade to break. Blade breakage is unavoidable, in some cases, since it is the natural result of the peculiar stresses that bandsaw blades must endure. Blade breakage is also due to avoidable circumstances. Avoidable blade breakage is most often the result of poor care or judgment on the part of the operator when mounting or adjusting the blade or support guides.

The most common causes of blade breakage are:

- Faulty alignment or adjustment of the blade guides.
- Forcing or twisting a wide blade around a tight radius.
- Feeding the workpiece too fast.
- Dull or damaged teeth.
- Over-tensioned blade.
- Top blade guide assembly set too high above the workpiece. Adjust the top blade guide assembly so that there is approximately $\frac{1}{8}$ "– $\frac{1}{4}$ " between the bottom of the assembly and the workpiece.

Note: The blade guide assembly can be lowered to within $2\frac{1}{2}$ " of the table surface.

- Using a blade with a lumpy or improperly finished braze or weld.
- Continuously running the bandsaw when not in use.
- Leaving the blade tensioned when not in use.
- Using the wrong blade pitch (TPI) for the workpiece thickness. The general rule of thumb is to have no fewer than two teeth in contact with the workpiece at all times during cutting.

Blade Care & Break-In

Blade Care

A bandsaw blade is a delicate piece of steel that is subjected to tremendous strain. A bandsaw blade will last longer if you give it fair treatment and always use the appropriate feed rate for your operation.

Be sure to select blades with the proper width, set, type, and pitch for each application. The wrong blade will produce unnecessary heat and have a shortened life.

A clean blade will perform much better than a dirty blade. Dirty or gummed up blades pass through the cutting material with much more resistance than clean blades. This extra resistance also causes unnecessary heat.

Blade Break-In

The tips and edges of a new blade are extremely sharp. Cutting at too fast of a feed rate can fracture these tips and edges, causing the blade to quickly become dull. Properly breaking-in a blade allows these sharp edges to wear properly without fracturing, thus keeping the blade sharp longer.

To properly break-in a new blade:

1. Choose the correct speed for the blade and material of the operation.
2. Reduce the feed pressure by half for the first 50–100 in² of material cut.
3. To avoid twisting the blade when cutting, adjust the feed pressure when the total width of the blade is in the cut.
4. Use the **Chip Inspection Chart** on **Page 29** to ensure that the optimal blade speed and feed rate are being used.

Blade Speed Chart

The chart in **Figure 19** offers blade speed guidelines for various metals, given in feet per minute (FPM) and meters per minute (M/Min). Choose the closest available speed on the machine, then adjust the feed rate as necessary, using the appearance of the chips produced as a guide. Refer to the **Chip Inspection Chart** that follows for recommendations on adjusting feed rate or blade speed based on the appearance of the chips produced.

Material	Speed FPM (M/Min)	Material	Speed FPM (M/Min)	Material	Speed FPM (M/Min)	Material	Speed FPM (M/Min)
Carbon Steel	196~354 (60) (108)	Tool Steel	203 (62)	Alloy Steel	111~321 (34) (98)	Free Machining Stainless Steel	150~203 (46) (62)
Angle Steel	180~220 (54) (67)	High-Speed Tool Steel	75~118 (25) (36)	Mold Steel	246 (75)	Gray Cast Iron	108~225 (33) (75)
Thin Tube	180~220 (54) (67)	Cold-Work Tool Steel	95~213 (29) (65)	Water Hardened Tool Steel	242 (75)	Ductile Austenitic Cast Iron	65~85 (20) (26)
Aluminum Alloy	220~534 (67) (163)	Hot-Work Tool Steel	203 (62)	Stainless Steel	85 (26)	Malleable Cast Iron	321 (98)
Copper Alloy	229~482 (70) (147)	Oil-Hardened Tool Steel	203~213 (62) (65)	CR Stainless Steel	85-203 (26) (62)	Plastics	220 (67)

Figure 19. Dry cutting blade speed chart.

Chip Inspection Chart

The best method for choosing the cutting speed and feed rate for a cutting operation is to inspect the chips created by the cut. These chips are indicators of what is commonly referred to as the "chip load." Refer to the chip inspection chart below to evaluate chip characteristics and determine whether to adjust feed rate/pressure, blade speed, or both.









Chip Appearance	Chip Description	Chip Color	Blade Speed	Feed Rate/Pressure	Other Actions
	Thin & Curled	Silver	Good	Good	
	Hard, Thick & Short	Brown or Blue	Increase	Decrease	
	Hard, Strong & Thick	Brown or Blue	Increase	Decrease	
	Hard, Strong, Curled & Thick	Silver or Light Brown	Good	Decrease Slightly	Check Blade Pitch
	Hard, Coiled & Thin	Silver	Increase	Decrease	Check Blade Pitch
	Straight & Thin	Silver	Good	Increase	
	Powdery	Silver	Decrease	Increase	
	Coiled, Tight & Thin	Silver	Good	Decrease	Check Blade Pitch

Figure 20. Chip inspection chart.

Positioning Guide Post Adjusting Blade Guides

The guide post assembly is used for two purposes: 1) To properly position the blade guard to protect the operator from the exposed blade between the workpiece and the upper wheel housing, and 2) to position the upper blade guides close to the workpiece for maximum blade support.

To properly position the guide post:

1. DISCONNECT BANDSAW FROM POWER!
2. Hold the guide post knob with one hand and loosen the guide post lock knob with the other (see **Figure 21**).

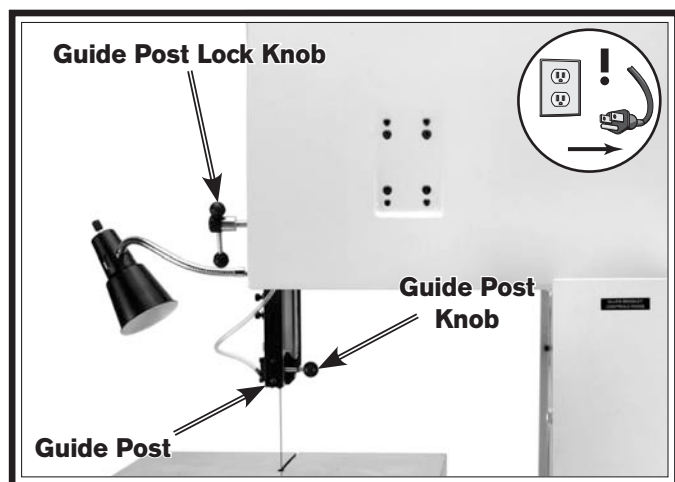
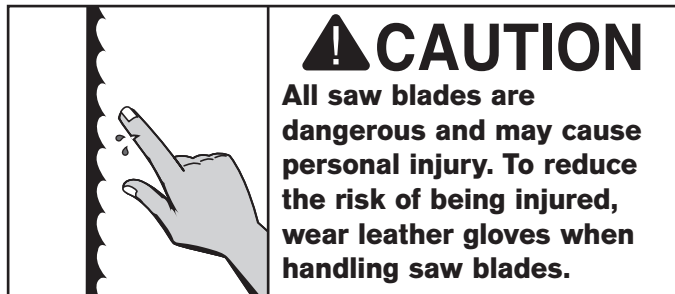

Figure 21. Guide post assembly.

3. Position the bottom of the upper blade guides approximately $\frac{1}{8}$ "– $\frac{1}{4}$ " above the workpiece, then re-tighten the lock knob to secure the setting.



Adjusting Blade Guides

The blade guides provide side-to-side and rear support to keep the blade straight while cutting. The blade guides and the rear support have tungsten steel facing to reduce wear on the guides. Properly adjusted blade guides are essential to making accurate cuts.

If the blade guides rub the blade at either the top or bottom of the blade, follow the guide post alignment procedure on **Page 42** for adjusting the guide post parallel with the blade.

To properly adjust the upper and lower blade guides:

1. DISCONNECT BANDSAW FROM POWER!
2. Make sure the bandsaw blade is properly tensioned (refer to **Page 27**) and the guide post is locked.
3. Use a Phillips head screwdriver to remove the flange screws that secure the lower blade guide cover, then remove the cover to access the cap screws in the next step.
4. Use a 5mm hex wrench to loosen the cap screws that secure the blade guide bracket and blade support (see **Figures 22–23**).

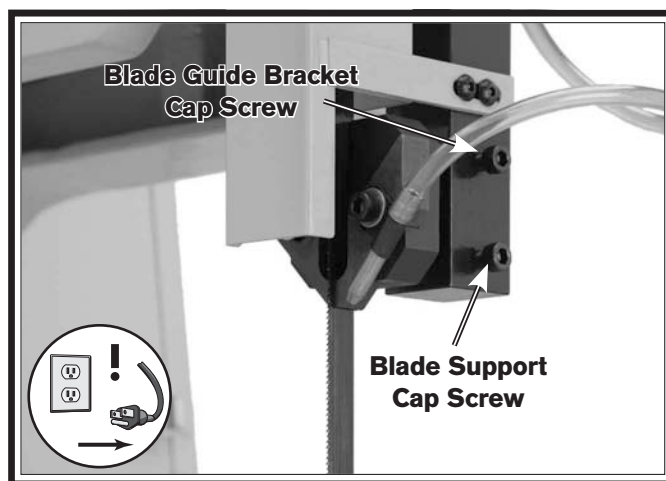

Figure 22. Upper blade guides and bracket.

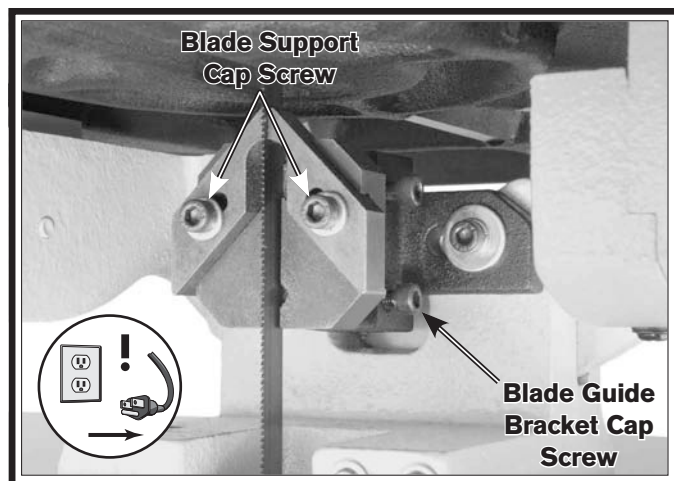

Figure 23. Lower blade guides and bracket.

5. Position the blade guides so that they are approximately $\frac{1}{16}$ " behind the tooth gullets (see **Figure 24**), then re-tighten the blade guide bracket cap screw.

Note: The blade guides must be adjusted far enough back so that they are behind the tooth gullets when the blade is deflected back against the blade support.

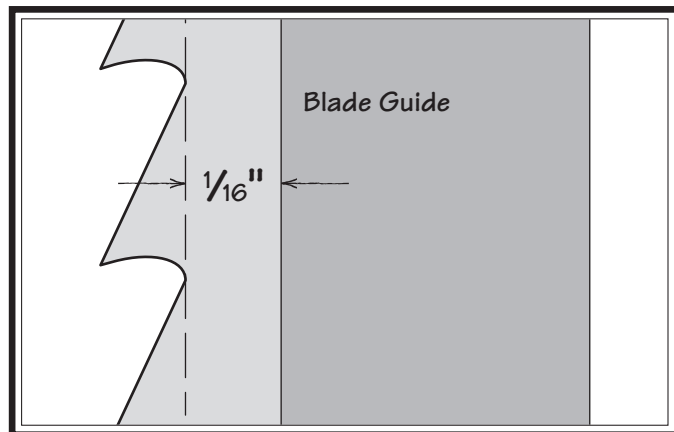

Figure 24. Blade guides positioned approximately $\frac{1}{16}$ " behind tooth gullets.

6. Slide the blade support (see **Figure 25**) up to, but not touching, the back of the blade, then re-tighten the blade support cap screw.

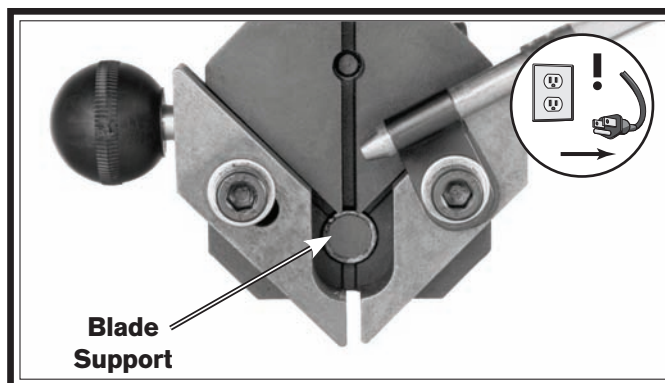

Figure 25. Blade guide assembly (upper assembly shown without blade for clarity).

7. Use a 3mm hex wrench to loosen the button head cap screws that secure the upper blade guard, to allow access to the blade support cap screw in the next step.
8. Use a 5mm hex wrench to loosen the blade guide cap screws (see **Figure 25**).
9. Fold a crisp dollar bill in half and place it over the blade (between the blade guides and the blade), as shown in **Figure 26**.

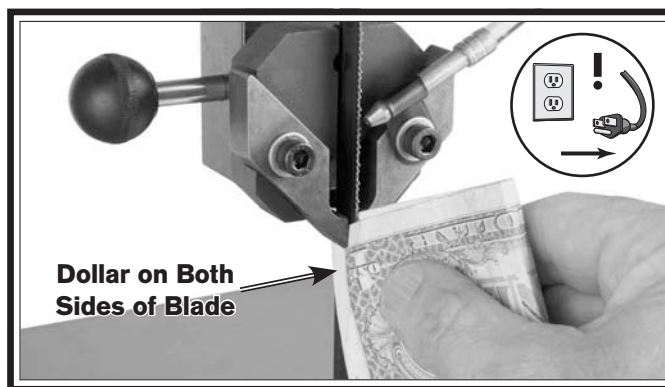

Figure 26. Using a dollar bill to set blade guide spacing (blade guide cover removed for clarity).

10. Lightly pinch the dollar bill against the blade with the blade guides, re-position the air nozzle if necessary, then re-tighten the blade guide cap screws.

Note: The goal is to position the blade guides as close as possible to the blade without touching it.

11. Secure the upper blade guide, then re-install the lower blade guard cover.

Tilting Table

The bandsaw table tilts 15° to the left and 15° to the right for basic cut angles, and 10° to the front and 10° to the back for feed angles. When used together, compound angled cuts can be made.

To tilt the table left or right:

1. DISCONNECT BANDSAW FROM POWER!
2. Use an 8mm wrench to loosen the two cap screws on the cut angle trunnion underneath the rear of the table (see **Figure 27**).

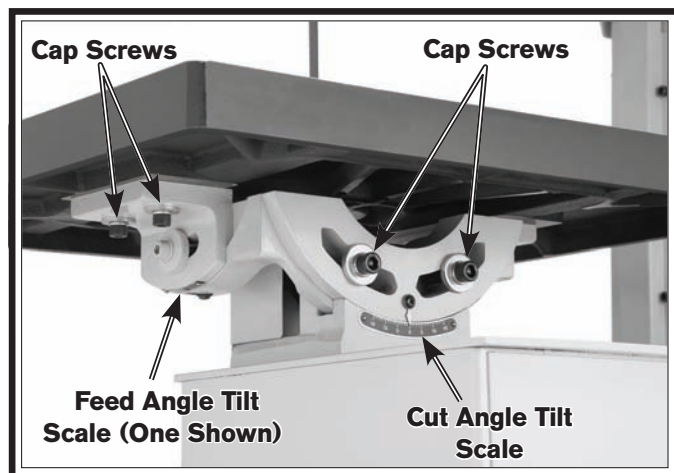

Figure 27. Table tilt adjustment controls.

3. Using the cut angle tilt scale, adjust the angle of the table for your operation, then re-tighten the cap screws.

To tilt the table forward or backward:

1. DISCONNECT BANDSAW FROM POWER!
2. Use a 6mm hex wrench to loosen both sets of cap screws on the two feed angle tilt scale brackets (see **Figure 27**).
3. Using the two scales, adjust the angle of the table for cutting a compound angle, then re-tighten the cap screws.

Blade Welding

Being able to quickly and safely weld a bandsaw blade comes in handy for the following situations:

- To re-join a blade that has been purposely cut for making an internal contour cut.
- To repair a broken blade that is still sharp and useful.
- To make a new blade from a roll of bulk blade banding.

Your metal cutting bandsaw is equipped with a blade welder that uses electrical current to heat and fuse the blade ends together. This process will leave the joint brittle, so an annealer is also included to give the blade strength and flexibility.

⚠ WARNING

The electric current that flows through the blade welder during operation could cause serious personal injury or death. To reduce the risk of electrocution or burns, never touch any metal part of the welding station or blade during welding or annealing.

To weld the ends of blade together:

1. Turn the bandsaw motor **OFF**.
2. Place the blade evenly against the back of the blade shear and firmly pull the handle down to square off the blade end (see **Figure 28**).



Figure 28. Using the blade shear to cut the blade.

Note: To make a proper blade weld, the ends of the blade must be evenly butted together during the welding process. If necessary, use the grinder to square up the ends or remove any teeth that are in the welding zone (see **Figures 29–30**).



Figure 29. Using the grinder to square up the blade end.

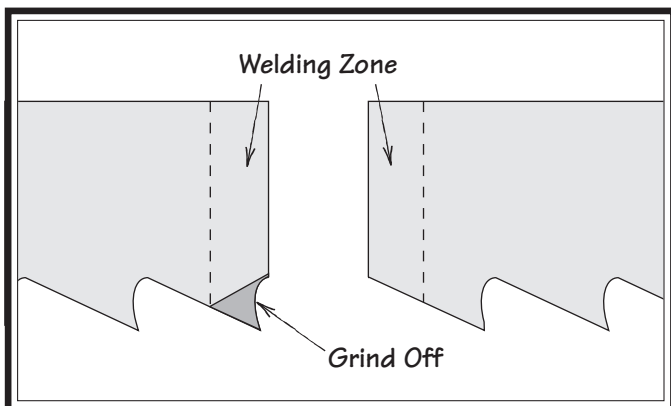

Figure 30. Blade ends and welding zone.

NOTICE

For good metal-to-metal contact between the welding clamps and the blade, make sure the blade material and the clamps are free from any debris or flashing before each use.

3. To ensure correct electrical continuity while welding, use mineral spirits to clean off all oil and debris from the first 6" of each end of the blade.
4. Set the clamping pressure to 0" with the clamping pressure dial.

5. Loosen the welding clamps by pulling the lock levers down.
6. Position the back of one blade end evenly against the back of the welding clamp so that the end is midway between the two clamps, then rotate the lock lever as far up as possible to hold the blade end in place (see **Figure 31**).

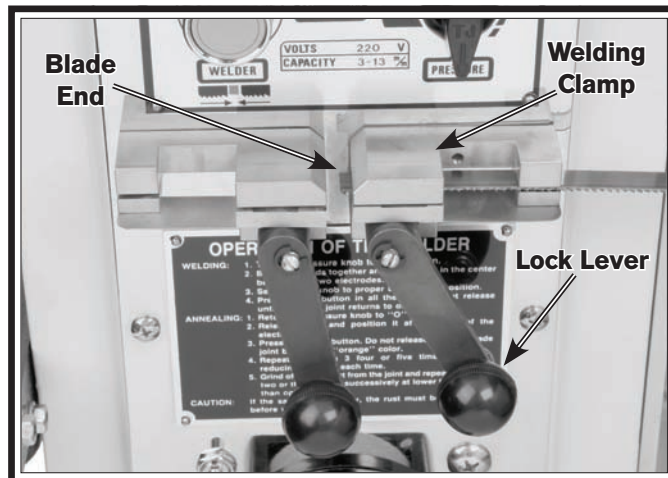

Figure 31. Blade end properly position in welding clamp and locked in place.

7. Use the illustration in **Figure 32** and set the correct clamping pressure setting for width of the blade.

Note: The clamping pressure presses the blade ends together to help form a strong weld. The pressure scale is an approximation only. If you have difficulty getting satisfactory welds, experiment by increasing or decreasing this pressure.

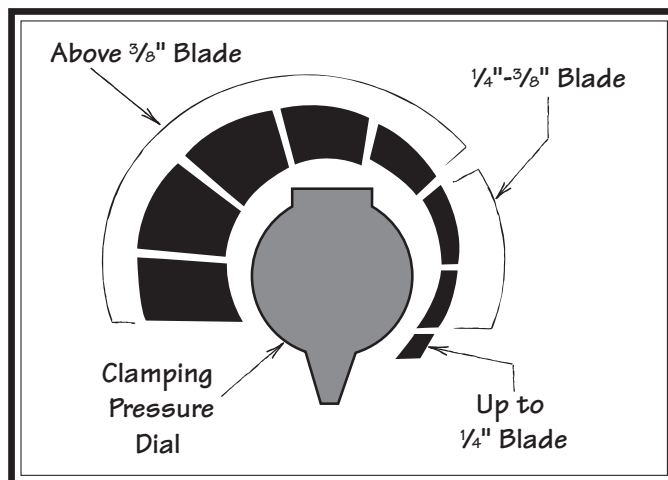

Figure 32. Blade clamping settings.

8. Place the other blade end in the opposite welding clamp and position it so that it evenly butts up against the opposing blade end, then lock it in place by rotating the lock lever all the way up, as shown in **Figure 33**.

Note: For a good blade weld, it is critical that the blade ends evenly butt up against each other without overlap, gaps, or misalignment.

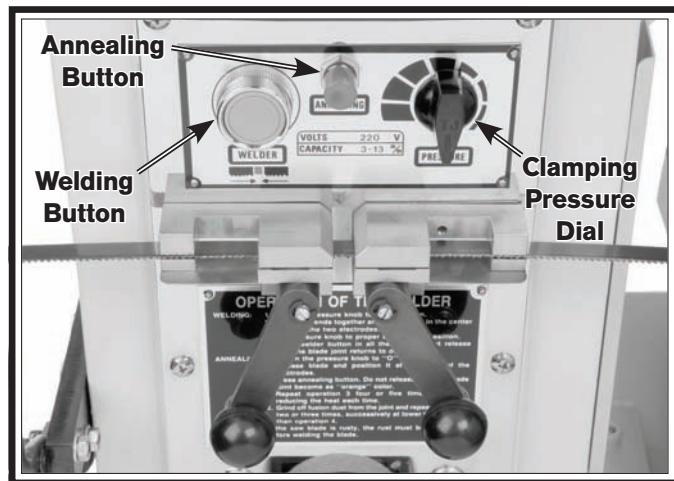

Figure 33. Blade ends in correct position for welding.

⚠️ WARNING

Light generated during the welding process could cause serious eye damage. To reduce your risk, always use eye protection approved for welding when using the blade welder.

⚠️ CAUTION

Burning sparks may be thrown in all directions while welding. Protect yourself from injury by not welding near flammables and wearing spark-resistant clothing/gloves. Keep fire extinguishing equipment readily available.

9. Press and release the welding button. The blade ends will be welded together.
10. Rotate the lock levers down to release the welding clamps, then rotate the clamping pressure dial to "0".

11. Inspect the weld. The welded joint should be even across the width of the blade with no gaps (see **Figure 34**).

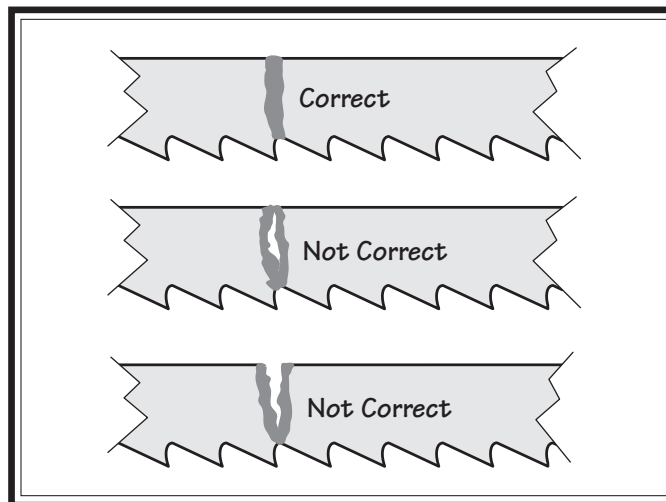

Figure 34. Blade welded joint examples.

- If the weld is satisfactory, continue to **Step 12**.
- If the weld is NOT satisfactory, begin again at **Step 2**.

12. Place the blade in the welding clamps with the weld centered between the clamps and re-tighten the lock levers.

Note: The welding operation leaves the blade joint brittle. Annealing allows the material to cool in gradual manner, giving the weld strength and flexibility. When annealing, the blade is heated until it turns a specific color that is determined by the blade material. The annealing process is unsuccessful (blade breaks easily) if the weld is not heated enough or if it is heated too much. For best results, contact the blade manufacturer for the proper annealing color.

13. Press and hold the annealing button until the weld zone turns the appropriate color, then release the button.

Note: If you cannot get the proper annealing color from the blade manufacturer, use the recommendations below as a baseline and experiment from there.

- Carbon Steel Dull Cherry Red
- Carbon Steel Hard Back Blue
- Bi-Metal Orange
- High Speed Steel Dull Cherry Red

14. Repeat **Step 13** three to four more times, allowing the weld to cool for about 30 seconds between each repetition. Each time reduce the amount of time you press the anneal button, to reduce the amount of heat successively.

15. Allow the blade to cool, then re-inspect the weld.

16. Grind away the weld bead on the top and bottom of the joint so that the blade is flat and will run smoothly on the wheels and between the blade guides.

Note: Make sure not to grind the teeth or blade body, or overheat the blade during grinding—this will weaken the blade. A small amount of ticking is acceptable during cutting operations.

17. Re-clamp the blade in the welding clamps with the joint centered, then repeat the annealing process twice more. Each time gradually reduce the amount of time you anneal the weld.

18. Test the strength and flexibility of the weld by bending the blade in an arc similar to that of the bandsaw wheels. The blade should bend in a smooth circular, rounded shape—rather than a pointed fold (see **Figure 35**).

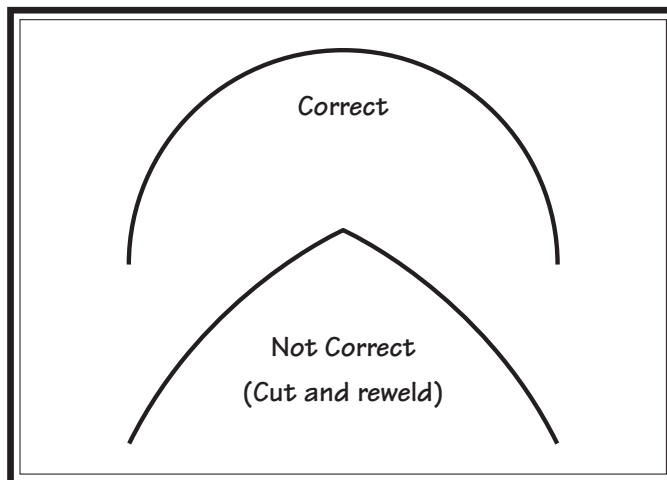

Figure 35. Correct blade weld bend for strength and flexibility.

Circle Cutting Jig

The Model SB1040/SB1041 includes a jig that attaches to the guide post to provide an easy and accurate method for cutting circular shapes.

The jig is capable of adjusting to fit a variety of workpiece dimensions and radii. The instructions on this page describe the general use of the jig so your particular setup may vary. Adjustments are made by loosening the cap screws or set screws that secure that hold the components in place. Always make sure all screws are fully tightened before beginning an operation.

If the curve you plan to cut does not touch an exposed edge of the workpiece, you will need to prepare the workpiece beforehand by making a cut up to the radius line or drilling a hole next to the radius line.

To use the circle cutting jig:

1. DISCONNECT BANDSAW FROM POWER!
2. Use the included M8-1.25 x 25 cap screws and lock washers to mount the circle cutting jig to the guide post, as shown in **Figure 36**.

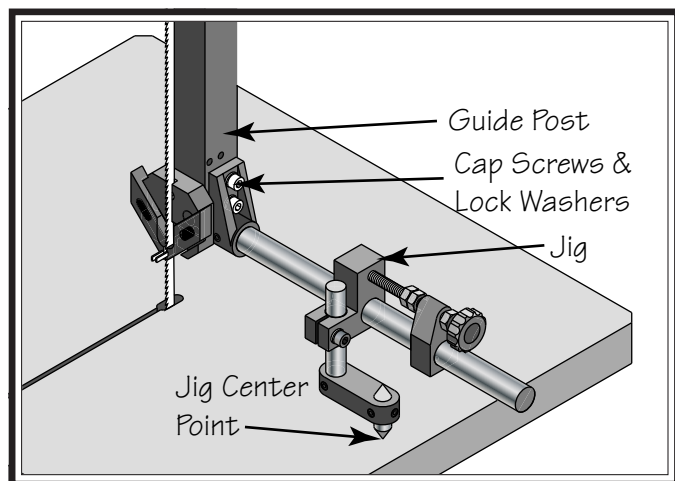

Figure 36. Circle cutting jig installed (some components removed for clarity).

3. Drill a small hole at the radius center point on your workpiece. The hole should be large enough that the jig center point can fit into it and provide a stable pivot point.

4. Install a blade with the proper width for radius of the circle you want to cut, using **Figure 14** on **Page 24** as a guide.
5. Adjust the jig as needed to position the center point away from the blade a distance equal to the radius of the arc you want to cut, and aligned with the blade, as shown in **Figure 37**

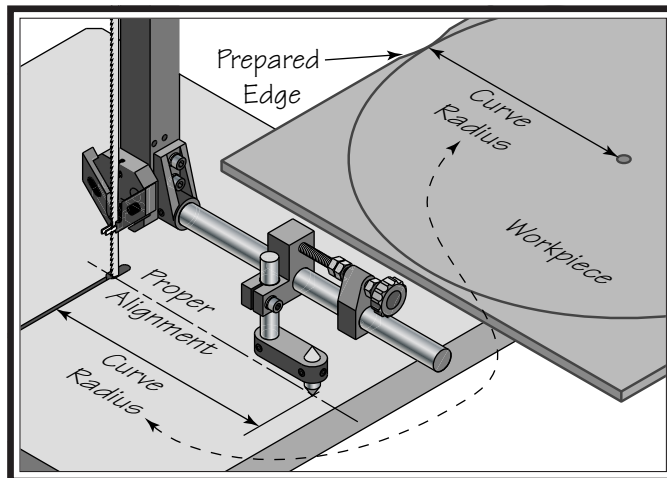
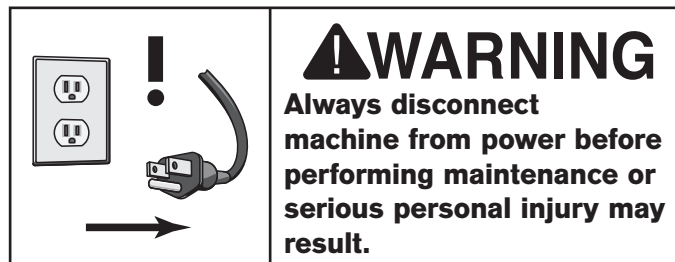

Figure 37. Adjusting curve radius (some components removed for clarity).

6. Place the workpiece on the table with the prepared edge next to, but not touching the blade, then lower the blade guides to within $\frac{1}{4}$ " of the workpiece (if possible), adjusting the jig centerpoint vertically as needed to provide clearance.
7. Lock the guide post, then lower the jig centerpoint into the centerpoint you drilled into the workpiece in **Step 3**. Tighten all of the fasteners on the jig to make sure it doesn't move during operation.
8. Turn the bandsaw **ON**, then feed the workpiece into the blade, rotating it around the centerpoint

Maintenance Schedule



For optimum performance from your machine, follow this maintenance schedule and refer to any specific instructions given in this section.

Daily:

- Check/correct loose mounting bolts.
- Check/correct damaged or dull saw blade.
- Check/correct worn or damaged wires.
- Clean/protect table.
- Clean metal chips from upper and lower wheel areas, and empty the chip chute.
- Correct any other unsafe condition.

Monthly:

- Check for V-belt tension, damage, or wear.
- Lubricate tension leadscrews and guide post rack.
- Remove the blade and clean the wheels.

Yearly:

- Open rear lower cover, inspect belts, and tighten all fasteners (see **Page 39**).

Cleaning

Use a brush and a shop vacuum to remove chips and other debris from the machine. Keep the table rust-free with regular applications of a high quality anti-rust product.

Once a month, remove the blade and thoroughly clean all metal chips or oil from the wheel surfaces. Redress the rubber tires if they become glazed.

When cleaning the wheel areas, empty and clean the chip chute and brush (see **Figure 38**).

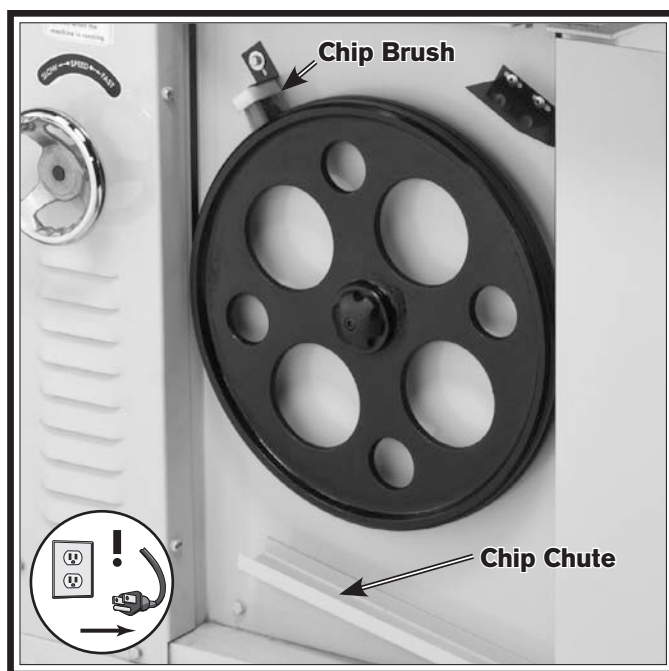

Figure 38. Lower wheel and chip chute.

Dressing Grinding Wheel

Periodically dress the grinding wheel to square it up and renew the abrasive surface. Dressing is done in the same manner as a typical grinding operation but using a diamond-tipped dressing tool (see **Figure 39**).

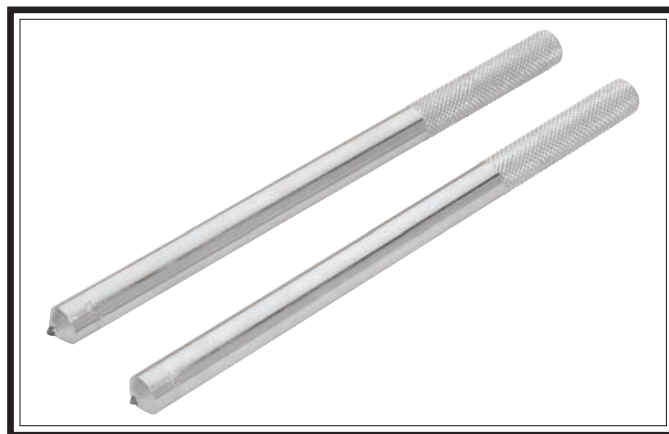

Figure 39. Example of diamond dressing tools.

Lubrication

The bearings on your bandsaw are factory lubricated and sealed. Leave them alone unless they need to be replaced.

When needed, brush a light coat of multi-purpose grease on the blade tension leadscrew (see **Figure 40**).

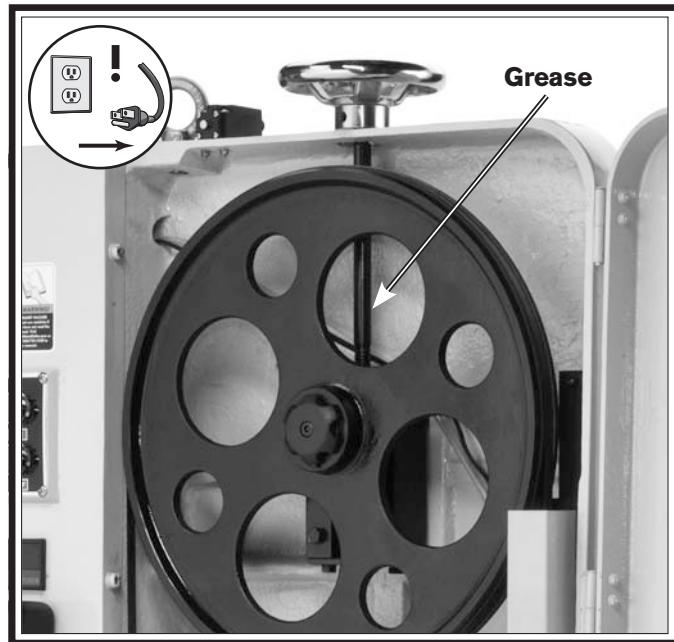

Figure 40. Upper wheel leadscrew lubrication.

Use multi-purpose grease and a light machine oil where indicated in **Figure 41**.

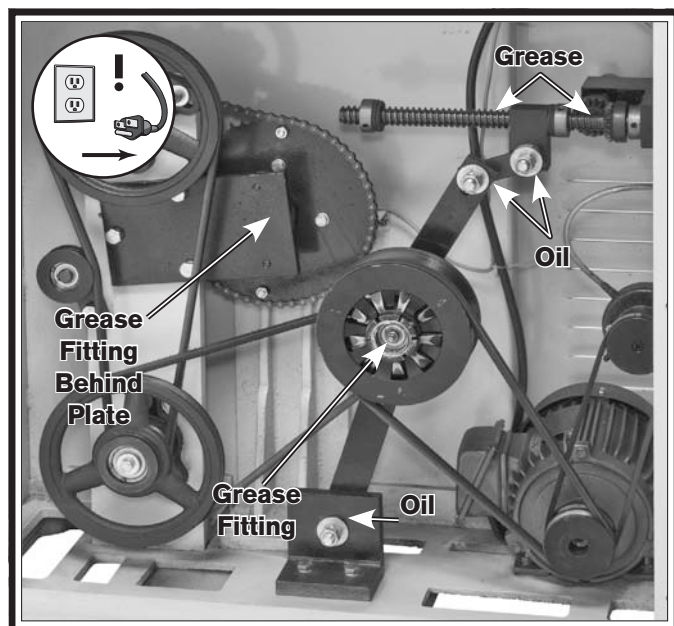

Figure 41. System lubrication points.

If the table becomes difficult to tilt, position it so that you can brush a thin coat of multi-purpose grease on the trunnion sliding surfaces (see **Figure 42**), then move the table back and forth to distribute.

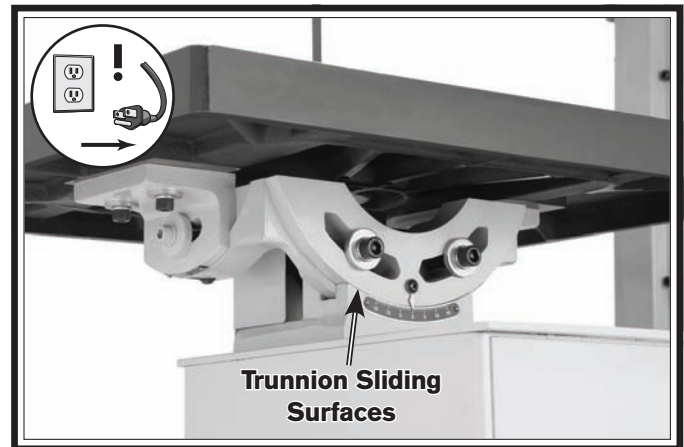

Figure 42. Trunnion lubrication.

The sliding surfaces on the guide post may occasionally need to be lubricated with a light machine oil if the movement becomes stiff.

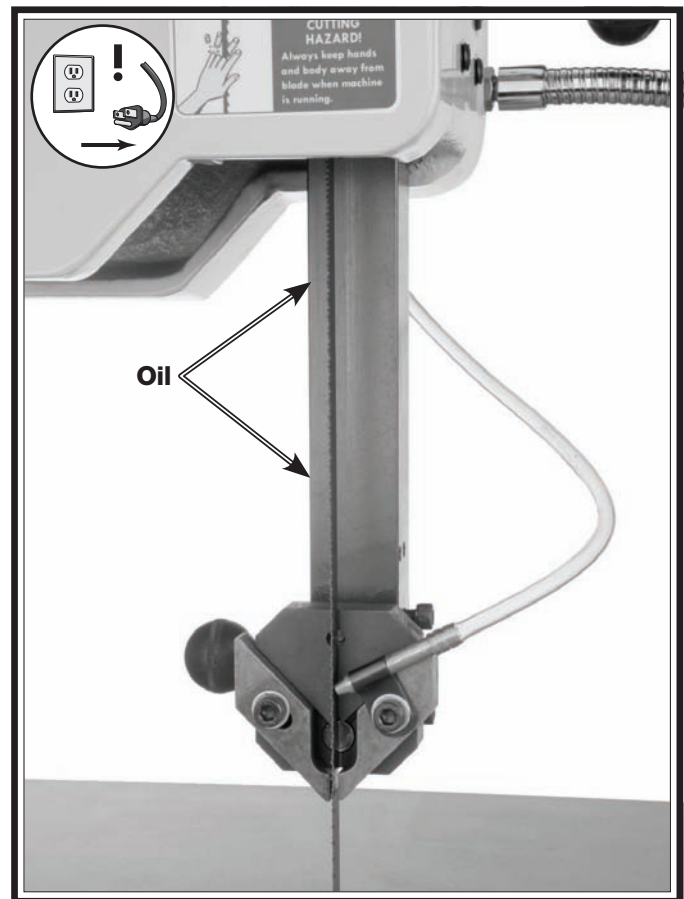

Figure 43. Guide post lubrication.

V-Belts

To ensure optimum power transfer from the motor to the blade, the V-belts must be in good condition and operate under proper tension.

Check V-belt tension at least every three months—more often if the bandsaw is used daily. V-belts stretch with use and must be periodically re-tensioned. Replace the V-belts if they are cracked, frayed, or badly worn. Refer to **Figure 44** to identify V-belt locations.

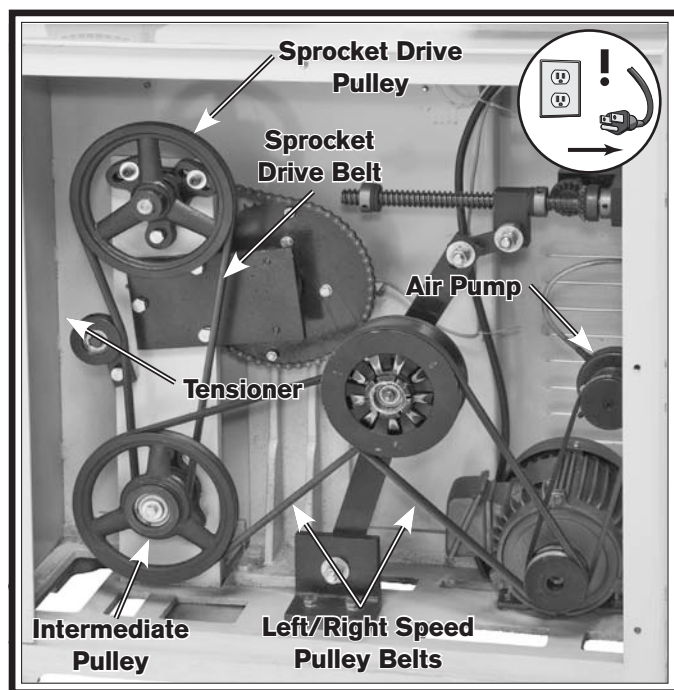

Figure 44. System belt and pulley layout.

To check/tension/replace the V-belts:

1. DISCONNECT BANDSAW FROM POWER!
2. Remove the rear motor access panel.
3. Push the center of each V-belt with moderate force. When tensioned correctly, there should be approximately $\frac{3}{16}$ " of deflection. DO NOT overtighten the belts or the bearings will wear prematurely.

Speed Hub Belts

Rotate the speed handwheel left or right until the belts are loose. Roll the belts off the pulleys to replace them. (If you get them mixed up when replacing, the belt on the left is the larger of the two.)

Note: When the machine is started, the belts will automatically adjust to the correct tension.

Sprocket Drive Belt

Use a 17mm wrench and loosen the tensioner hex bolt. Next use a 6mm hex wrench to loosen the three intermediate pulley retaining cap screws so the belt is loose. Replace the sprocket drive belt. Re-tighten the intermediate hub and adjust the tensioner hub to tension the new belt.

Air Pump Belt

Use a 10mm wrench to loosen the pump mounting bolts, replace the belt and tension it by positioning the air pump, then tighten the mounting bolts.

Note: Make sure that when tightened, the pump pulley is aligned with the motor drive pulley.

Dressing Rubber Tires

As the bandsaw ages, the rubber tires on the wheel may need to be redressed if they become hardened or glazed over. Dressing the rubber tires improves blade tracking and reduces vibration/blade lead.

If the rubber tires become too worn, then blade tracking will become extremely difficult. At that point, redressing will no longer be effective, and the rubber tires must be replaced.

To redress the rubber tires:

1. DISCONNECT BANDSAW FROM POWER!
2. Put on heavy gloves and remove the blade.
3. Use a brush and shop vacuum to clean any chips from the rubber tires.
4. Hold a piece of 100-grit sandpaper against the rubber tire and rotate the wheel by hand. Only redress the rubber enough to expose a fresh rubber surface.
5. Check surface area of tire to ensure a uniformly sanded surface.

Machine Storage

All machinery will develop serious rust problems and corrosion damage if it is not properly prepared for storage. If decommissioning this machine, use the steps in this section to ensure that it remains in good condition.

To prepare your machine for storage or decommission it from service:

1. Disconnect all power sources to the machine.
2. Thoroughly clean all unpainted, bare metal surfaces, then coat them with a light weight grease or rust preventative. Take care to ensure these surfaces are completely covered but that the grease or rust preventative is kept off of painted surfaces.
3. Loosen or remove the belts and blade so they do not become stretched while the machine is out of use. Tag the machine to indicate that the belts and blade are loose.
4. Completely cover the machine with a tarp or plastic sheet that will keep out dust and resist liquid or moisture. If machine will be stored in/near direct sunlight, use a cover that will block the sun's rays.

Note: If the machine will be out of service for only a short period of time, use way oil or a good grade of medium-weight machine oil (not auto engine oil) in place of the grease or rust preventative.

Blade Tracking

A blade that is tracking correctly runs cooler, reduces wear-and-tear on the machine, and increases cutting performance. When tracking correctly, the blade rides next to, but not against, the wheel flange. The tracking is controlled by adjusting the upper wheel.

To adjust the upper wheel for blade tracking:

1. DISCONNECT BANDSAW FROM POWER!
2. Make sure the blade guides are adjusted away from the blade so they will not interfere with the change of blade position.
3. Ensure that the blade is correctly tensioned.
4. Using a 6mm hex wrench, loosen the four locking cap screws (see **Figure 45**).

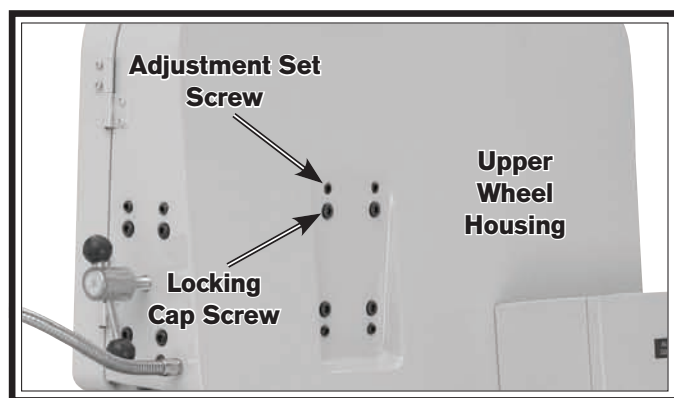

Figure 45. Wheel alignment.

5. Use a 5mm hex wrench to adjust the four set screws (**Figure 45**) to tilt the upper wheel in or out and bring blade tracking back to normal. Only adjust each screw in small increments.
6. Rotate the upper wheel by hand a couple times in the normal direction of rotation. Verify that the blade tracks next to, but not against, the wheel flange. Repeat **Steps 5–6** if necessary until the blade tracks correctly.
7. Tighten the locking cap screws and recheck the tracking to make sure it did not change. If it did, repeat **Steps 4–7**.
8. Adjust the blade guides back to their correct position.

Table Calibration

To ensure the accuracy of angle cuts and compound angle cuts, the scale pointers must point to zero when the table is perpendicular or 90° to the blade.

To calibrate the table to zero:

1. DISCONNECT BANDSAW FROM POWER!
2. Make sure the blade tracking and tension are set correctly.
3. Using a 6mm hex wrench, loosen the trunnion cap screws (see **Figure 46**).

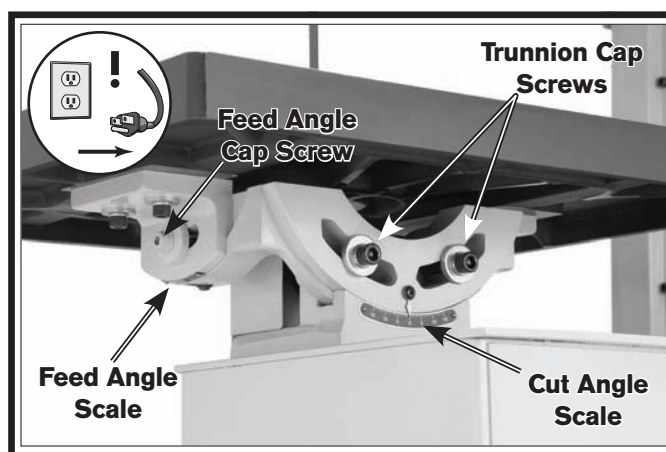

Figure 46. Location of table scales.

4. Place a machinist's square on the table and against the side of the blade, as shown in **Figure 47**.

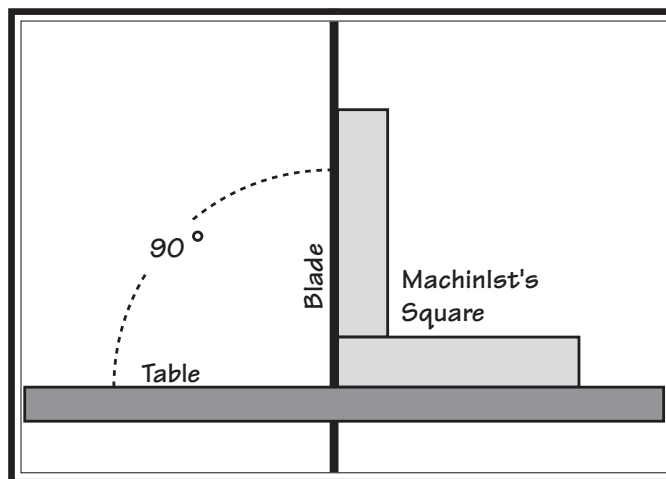

Figure 47. Checking that table is perpendicular to blade.

5. Tilt the table until the blade and table top are perpendicular, then tighten the trunnion cap screws.
6. Loosen the scale pointer for the cut angle scale (on the trunnion) and point it to zero.
7. Loosen the feed angle cap screw and place the machinist's square against the back of the blade.
8. Position the table perpendicular to the blade.
9. Tighten the feed angle cap screws.
10. Loosen the pointer for the feed angle scale, point it to zero, then retighten it. The table and blade are now calibrated.

Guide Post Alignment

If the blade guide post does not raise and lower exactly parallel with the blade, the clearances between the blade guides and blade will change as the guide post is moved, causing rubbing, wear, and blade deflection. Blade guide clearance must stay the same when the guide post is raised and lowered along its full length of travel.

To align the guide post:

1. DISCONNECT BANDSAW FROM POWER!
2. Make sure the blade tracking and tension are set correctly.
3. Lower the blade guide post to the bottom of its travel and lock it in place.
4. Adjust the blade guides as described on **Page 30**.
5. Unlock the post just enough to allow it to slide, move it all the way up, then examine the clearances between the blade and blade guides to see if they changed.

If these clearances changed beyond your acceptable tolerances, the blade guide receiver (see **Figure 48**) can be adjusted to fix this condition.



Figure 48. Guide post system.

6. Using a 6mm hex wrench, loosen the four receiver cap screws (see **Figure 49**).

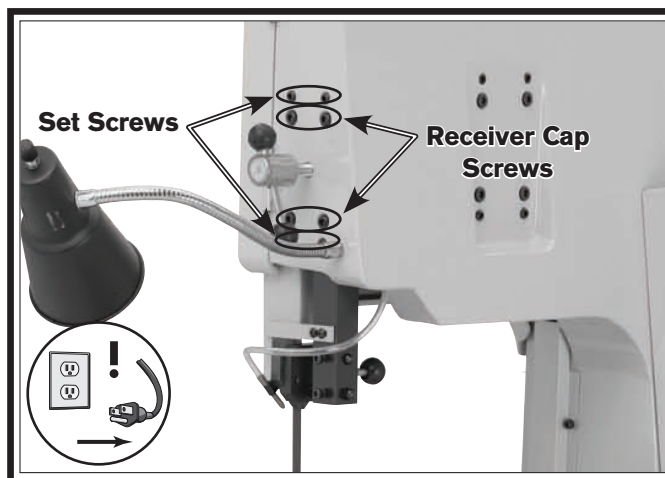

Figure 49. Guide post alignment controls.

7. Using a 5mm hex wrench, adjust the four set screws to tilt the blade guide receiver in the required direction.
8. Tighten the cap screws and recheck blade guide clearance along the guide post path of travel.
9. Repeat this procedure if necessary to fine-tune the guide post travel to acceptable tolerances.

Bevel Gear Backlash

During the life of the machine, the variable speed handwheel may develop extra backlash due to normal wear of the bevel gears. If this lash becomes unacceptable, use this procedure to reduce the backlash.

To reduce the bevel gear backlash:

1. DISCONNECT BANDSAW FROM POWER!
2. Remove the rear lower access panel, and use a 4mm hex wrench to loosen both bevel gear locking set screws (see **Figure 50**) just enough to adjust the bevel gears.

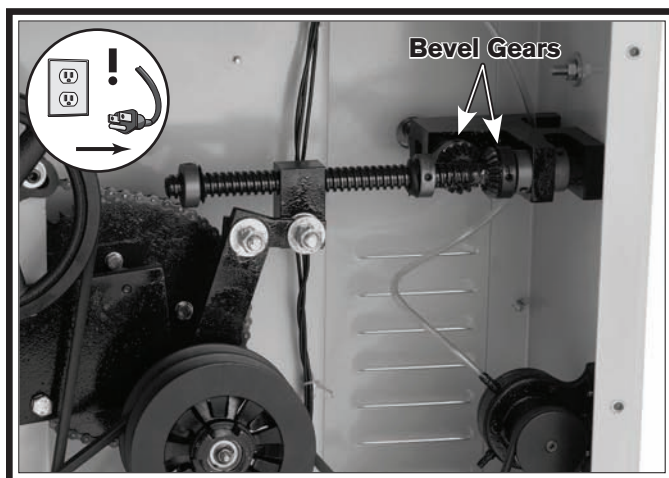

Figure 50. Location of bevel gears.

3. Slide the bevel gears closer together and tighten the set screws. If excess backlash still exists, refer to the **Leadscrew End Play** section on this page, then proceed to **Step 4**.

Note: Make sure that the set screws remain aligned with the flats on the shaft. If one or both set screws does not return to their original depth in the bevel gear after tightening, the alignment has probably been lost and needs to be corrected.

4. Clean and grease the bevel gears and the leadscrew, then reinstall the access panel.

Leadscrew End Play

If you notice that the leadscrew has end play and the variable speed handwheel has excess backlash after the bevel gear lash has been set, you can adjust the leadscrew collars as an additional measure to reduce the backlash.

To adjust the leadscrew collars to reduce backlash:

1. DISCONNECT BANDSAW FROM POWER!
2. Remove the rear lower access panel, and use a 4mm hex wrench to loosen both collar locking set screws just enough to adjust the collars (see **Figure 51**).

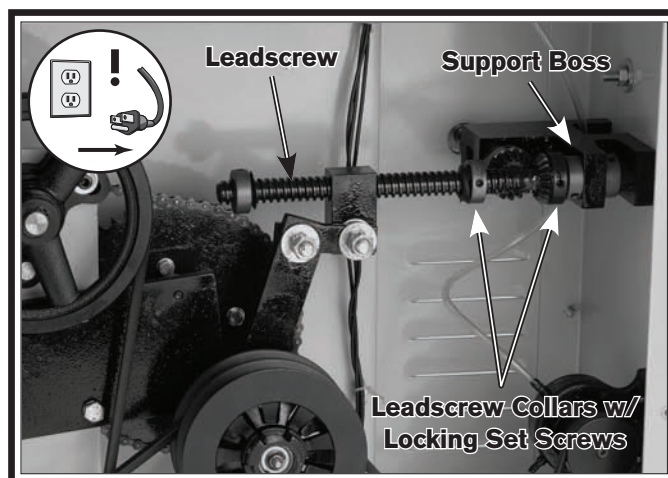

Figure 51. Leadscrew adjustment locations.

3. Slide the right-hand leadscrew collar against the support boss and tighten the set screws. If excess backlash still exists at the handwheel, you may have to readjust the bevel gear lash, replace the leadscrew half nut, or replace worn bolts or linkage (see **Figure 51**).

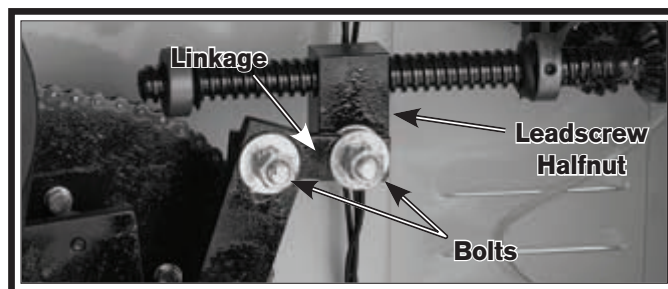

Figure 52. Linkage location and parts.

4. Reinstall the access panel.

Troubleshooting

If you need replacement parts, or if you are unsure how to do any of the solutions given here, feel free to call us at (360) 734-1540.

Symptom	Possible Cause	Possible Solution
Machine does not start.	<ol style="list-style-type: none"> 1. Power supply switched off/has incorrect voltage. 2. Blown fuse/tripped circuit breaker at main panel. 3. Plug or receptacle is corroded or mis-wired. 4. Thermal overload relay has tripped. 5. Break or short in wiring; or loose connections. 6. Motor ON/OFF switch at fault. 7. Motor connection wired incorrectly. 8. Start capacitor blown or at fault. 9. Contactor not energized/has poor contacts. 10. Centrifugal switch at fault. 11. Motor at fault. 	<ol style="list-style-type: none"> 1. Switch power supply on/verify voltage. 2. Correct the cause of overload, then reset/replace fuse or breaker. 3. Clean/retighten contacts; correct the wiring. 4. Allow relay/motor to cool. If necessary, press reset button inside switch. 5. Trace/replace broken or corroded wires; fix loose connections. 6. Replace switch. 7. Wire motor correctly (refer to inside junction box cover or manual). 8. Replace start capacitor. 9. Test all legs for power, test field coil and replace if at fault. 10. Adjust/replace centrifugal switch. 11. Test for shorted windings, bad bearings and repair or replace.
Main motor chatters during startup or during operation.	<ol style="list-style-type: none"> 1. Extension cord (if used) is causing voltage drop. 2. Phase converter (if used) wild wire connected wrong. 3. Power supply has incorrect or unacceptable voltage. 	<ol style="list-style-type: none"> 1. Move machine closer to the power source or use a larger gauge or shorter extension cord. 2. Connect wild wire to the machine power supply terminal that is not part of the contactor field coil power supply circuit (see Page 53). 3. Contact your power company to fix the power supply.
Machine operates in reverse.	<ol style="list-style-type: none"> 1. Power connections wired out of phase (SB1041 only). 	<ol style="list-style-type: none"> 1. Swap two power incoming power leads (see Page 20).
Machine has excessive vibration or noise.	<ol style="list-style-type: none"> 1. Motor fan rubbing on fan cover. 2. Motor or table is loose. 3. V-belt(s) loose. 4. Guide post lock lever is loose. 5. Machine incorrectly mounted on floor. 6. V-belt(s) worn or damaged. 7. Pulley loose or not in alignment; shaft bent. 8. Centrifugal switch out of adjustment or at fault (SB1040 only). 9. Motor bearings worn or damaged. 10. Phase converter (if used) wild wire incorrectly connected (SB1041 only). 	<ol style="list-style-type: none"> 1. Fix/replace fan cover; replace loose or damaged fan. 2. Tighten any loose fasteners. 3. Tighten V-belt(s). 4. Tighten the lock lever. 5. Level/shim base; tighten/adjust mounting hardware or feet. 6. Replace V-belt(s). Use link belts if possible. 7. Replace worn pulley, key, and shaft, and realign. 8. Adjust/replace centrifugal switch. 9. Replace motor bearings or replace motor. 10. Connect wild wire to correct leg (must avoid transformer or sensitive electronics); (see Page 53).

Symptom	Possible Cause	Possible Solution
Vibration when operating or cutting.	<ol style="list-style-type: none"> 1. Loose or damaged blade. 2. Worn wheel bearing. 3. Wheels are not coplanar. 4. Wheel tires worn or incorrectly installed. 5. Bent or dull blade. 6. Wheels out of balance. 7. Loose machine component. 8. Belt has a high spot. 9. Bandsaw blade wheel is bent or out of balance. 	<ol style="list-style-type: none"> 1. Tighten or replace blade. 2. Check/replace wheel bearing. 3. Adjust wheels so they are parallel and aligned. 4. Replace or dress rubber tires. 5. Replace blade. 6. Replace wheels. 7. Tighten loose component. 8. Replace/adjust the V-belt. 9. Check and replace for bad wheel or bearing.
Machine stalls or slows when operating.	<ol style="list-style-type: none"> 1. Too much pressure when feeding workpiece. 2. Motor is wired out of phase (SB1041 only). 3. Workpiece is warped and binding blade. 4. Blade is not correct for material being cut. 5. Belt(s) slipping. 6. Motor overheated. 7. Run capacitor at fault (SB1040 only). 8. Pulley or sprocket slipping on shaft. 9. Motor connection wired incorrectly. 10. Contactor has poor contacts. 11. Centrifugal switch at fault (SB1040 only). 12. Motor at fault. 	<ol style="list-style-type: none"> 1. Reduce pressure when feeding workpiece. 2. Swap two power incoming power leads (see Phase Polarity on Page 20). 3. Fabricate a jig for better workpiece control. 4. Use the correct blade for the operation. Refer to Blade Selection section beginning on Page 24. 5. Tension/replace belt(s); ensure pulleys are aligned. 6. Let cool, clean motor, and reduce workload. 7. Test/repair/replace. 8. Replace pulley and key or set screw. Replace shaft if worn. 9. Review wiring diagram on motor cover; correct wire connections. 10. Test all legs for power, test field coil and replace if at fault. 11. Adjust/replace centrifugal switch if available. 12. Test for shorted windings, bad bearings and repair or replace.

Continued On Next Page



Symptom	Possible Cause	Possible Solution
Machine or blade bogs down in the cut.	<ol style="list-style-type: none"> 1. Excessive load on the blade. 2. V-belts loose; belt squeals at times. 3. V-belts worn and slips. 4. Blade is loading up. 5. Blade is dull, wanders, and gets pinched in the cut. 6. Blade is dull. 7. The blade TPI is too coarse for the thin workpiece. 8. Blade is loose. 9. Material requires cutting fluid. 10. The run capacitor is at fault (SB1040 only). 	<ol style="list-style-type: none"> 1. Reduce feed rate or increase blade speed (see Page 29). 2. Tighten V-belts(see Page 39). 3. Replace V-belts (see Page 39). 4. Install a blade with more suitable TPI or different style of teeth. 5. Replace blade, adjust guides and tracking (see Page 41). 6. Replace blade (see Page 27). 7. Use a blade with at least 2 teeth contacting the material at all times. 8. Clean wheels and increase blade tension (see Page 27). 9. Use applicable cutting fluid. 10. Replace the run capacitor (see Wiring on Page 48).
Ticking sound when the saw is running.	<ol style="list-style-type: none"> 1. Blade weld contacting blade guides. 2. Blade weld may be failing. 	<ol style="list-style-type: none"> 1. Grind blade weld down smaller. 2. Cut and reweld the blade, or replace the blade.
Cuts are not square or the intended angle is incorrect.	<ol style="list-style-type: none"> 1. Pointer or scale not calibrated or loose table. 2. Table guide post is loose or out of alignment. 	<ol style="list-style-type: none"> 1. Zero table to blade and realign scale pointers (see Page 41). Tighten any loose fasteners. 2. Tighten any loose hardware or lock levers. Align the guide post (see Page 42).
Blade dulls prematurely, or metal sticking to the blade.	<ol style="list-style-type: none"> 1. Blade is improperly broken in. 2. The blade gullets are loading up with chips. 3. The blade TPI is too fine for the thick workpiece, and the teeth load up and overheat. 4. The workpiece has hard spots, welds, or scale. 	<ol style="list-style-type: none"> 1. Replace blade, and complete blade break in procedure. 2. Use a blade that has larger gullets to carry out material. 3. Use a coarser-tooth blade, adjust feed rate, adjust blade speed, make sure the brush is working. 4. Replace the blade with a special blade for cutting hardened materials.
Handwheel has excessive backlash, endplay, binds, or is difficult to move.	<ol style="list-style-type: none"> 1. Leadscrew is dirty or lacks proper lubrication. 2. Bevel gears out of adjustment. 3. Bearing or leadscrew collar is worn or loose. 4. Linkage bolts, pins, and holes are loose or worn. 5. Leadscrew or leadscrew nut worn. 	<ol style="list-style-type: none"> 1. Clean and lubricate the leadscrew (see Page 38). 2. Re-adjust bevel gears to reduce backlash (see Page 43). 3. Replace bearing or readjust leadscrew collar (see Page 43). 4. Replace linkage bolts, pins, and re-bush any worn pin holes. 5. Replace leadscrew or leadscrew nut.

Symptom	Possible Cause	Possible Solution
Blade tracks incorrectly, or comes off wheels.	<ol style="list-style-type: none"> 1. Feed rate is too fast. 2. Blade is not tracking correctly. 3. Blade is bell-mouthed. 4. Blade is dull, wanders, and gets pinched in the cut. 5. Rubber tire on wheel is damaged, glazed, or worn. 6. Blade tension is too loose. 7. Blade guides need adjustment. 8. Incorrect blade for bandsaw. 9. The blade has insufficient support. 10. Wheel tires are loaded with metal shavings. 	<ol style="list-style-type: none"> 1. Reduce feed rate, or decrease blade TPI. 2. Adjust blade tracking (see Page 41). 3. Install new blade, and regularly remove tension from blade when not in use (see Page 27). 4. Replace blade, re-secure the workpiece from shifting. 5. Replace or dress rubber tires. 6. Increase blade tension (see Page 27). 7. Adjust blade guides (see Page 30). 8. Install correct blade for machine. 9. Tighten the blade guide as close to the workpiece as possible. 10. Clean wheel tires.
The cut is crooked, the blade wanders, slow cuts, or shows overheating on one side of the cut or the blade.	<ol style="list-style-type: none"> 1. Blade spinning backwards due to machine being wired out of phase (SB1041 only). 2. The feed pressure is too high. 3. Too much side pressure when feeding workpiece. 4. Blade is loading up. 5. Blade installed backwards. 6. Dull blade; missing teeth. 7. Blade too wide for size of radius being cut. 8. The blade speed is wrong. 9. The blade tracking is wrong. 	<ol style="list-style-type: none"> 1. Swap two power incoming power leads (see Phase Polarity on Page 20). 2. Decrease the feed rate. 3. Feed workpiece straight into the blade. 4. Install a blade with more suitable TPI or different style of teeth. 5. Check blade rotation as described in “test run” and reverse blade if necessary. 6. Replace blade. 7. Install a smaller width blade, or increase blade tension (see Page 27). 8. Adjust feed rate and cutting speed as required. 9. Adjust the blade tracking (see Page 41).
Grinder does not work.	<ol style="list-style-type: none"> 1. Wiring or ON/OFF switch at fault 2. Motor at fault. 	<ol style="list-style-type: none"> 1. Repair wiring or replace grinder switch. 2. Replace motor.
Work lamp or welding lamp does not work	<ol style="list-style-type: none"> 1. Bulb, wiring, or switch at fault. 2. Transformer is at fault. 	<ol style="list-style-type: none"> 1. Replace bulb, repair wiring, replace switch. 2. Replace transformer.
Welder is inoperative or welds poorly.	<ol style="list-style-type: none"> 1. Operator error. 2. Wiring or welding switch at fault. 3. Welder transformer at fault. 	<ol style="list-style-type: none"> 1. Use welder as outlined in operations section and practice on scrap blades (see Page 32). 2. Repair wiring or replace welding switch. 3. Replace welder transformer.

Electrical Safety Instructions

These pages are accurate at the time of printing. In the constant effort to improve, however, we may make changes to the electrical systems of future machines. Study this section carefully. If you see differences between your machine and what is shown in this section, call Technical Support at (360) 734-1540 for assistance BEFORE making any changes to the wiring on your machine.

- 1. Shock Hazard:** It is extremely dangerous to perform electrical or wiring tasks while the machine is connected to the power source. Touching electrified parts will result in personal injury including but not limited to severe burns, electrocution, or death. For your own safety, disconnect machine from the power source before servicing electrical components or performing any wiring tasks!
- 2. Wire Connections:** All connections must be tight to prevent wires from loosening during machine operation. Double-check all wires disconnected or connected during any wiring task to ensure tight connections.
- 3. Modifications:** Using aftermarket parts or modifying the wiring beyond what is shown in the diagram may lead to unpredictable results, including serious injury or fire.
- 4. Motor Wiring:** The motor wiring shown in these diagrams is current at the time of printing, but it may not match your machine. Always use the wiring diagram inside the motor junction box.
- 5. Circuit Requirements:** Connecting the machine to an improperly sized circuit will greatly increase the risk of fire. To minimize this risk, only connect the machine to a power circuit that meets the minimum requirements given in this manual.
- 6. Capacitors/Inverters:** Some capacitors and power inverters store an electrical charge for up to 10 minutes after being disconnected from the power source. To reduce the risk of being shocked, wait at least this long before working on capacitors.
- 7. Wire/Component Damage:** Damaged wires or components increase the risk of serious personal injury, fire, or machine damage. If you notice that any wires or components are damaged while performing a wiring task, replace those wires or components before completing the task.
- 8. Experiencing Difficulties:** If you are experiencing difficulties understanding the information included in this section, contact our Technical Support at (360) 734-1540.

Wiring Overview

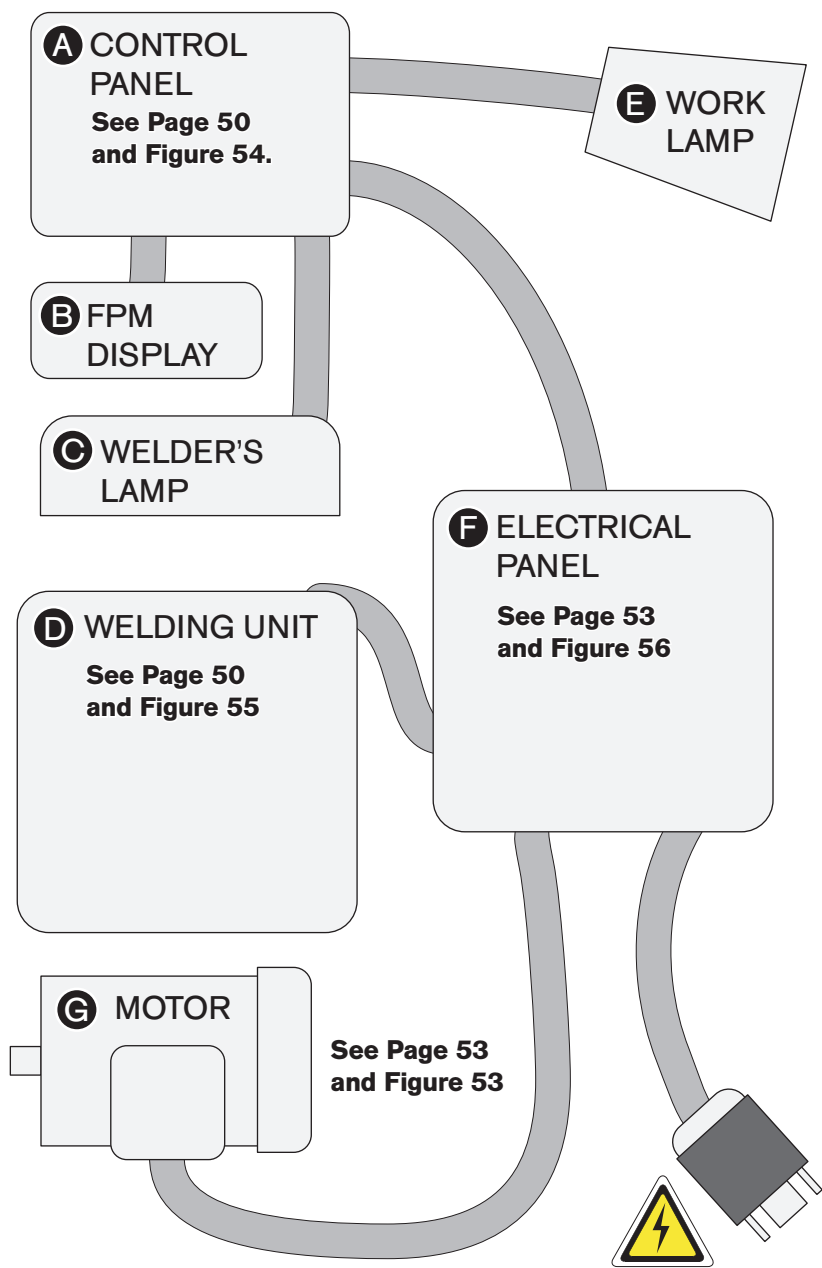

* May Represent Multiple Wires

WIRING DIAGRAM COLOR KEY

BLACK — Bk —	BLUE WHITE — Bw —	RED — Rd —	PINK — Pk —	WHITE — Wt —
BLUE — Bl —	GREEN — Gn —	LIGHT BLUE — Lb —	PURPLE — Pu —	YELLOW GREEN — Yg —
BROWN — Br —	GRAY — Gy —	ORANGE — Or —	TUR-QUIOSE — Tu —	YELLOW — Yl —

NOTICE: The photos and diagrams included in this section are best viewed in color. You can see them in color at www.southbendlathe.com.

SB1040/SB1041 Control Panel/Welding Unit

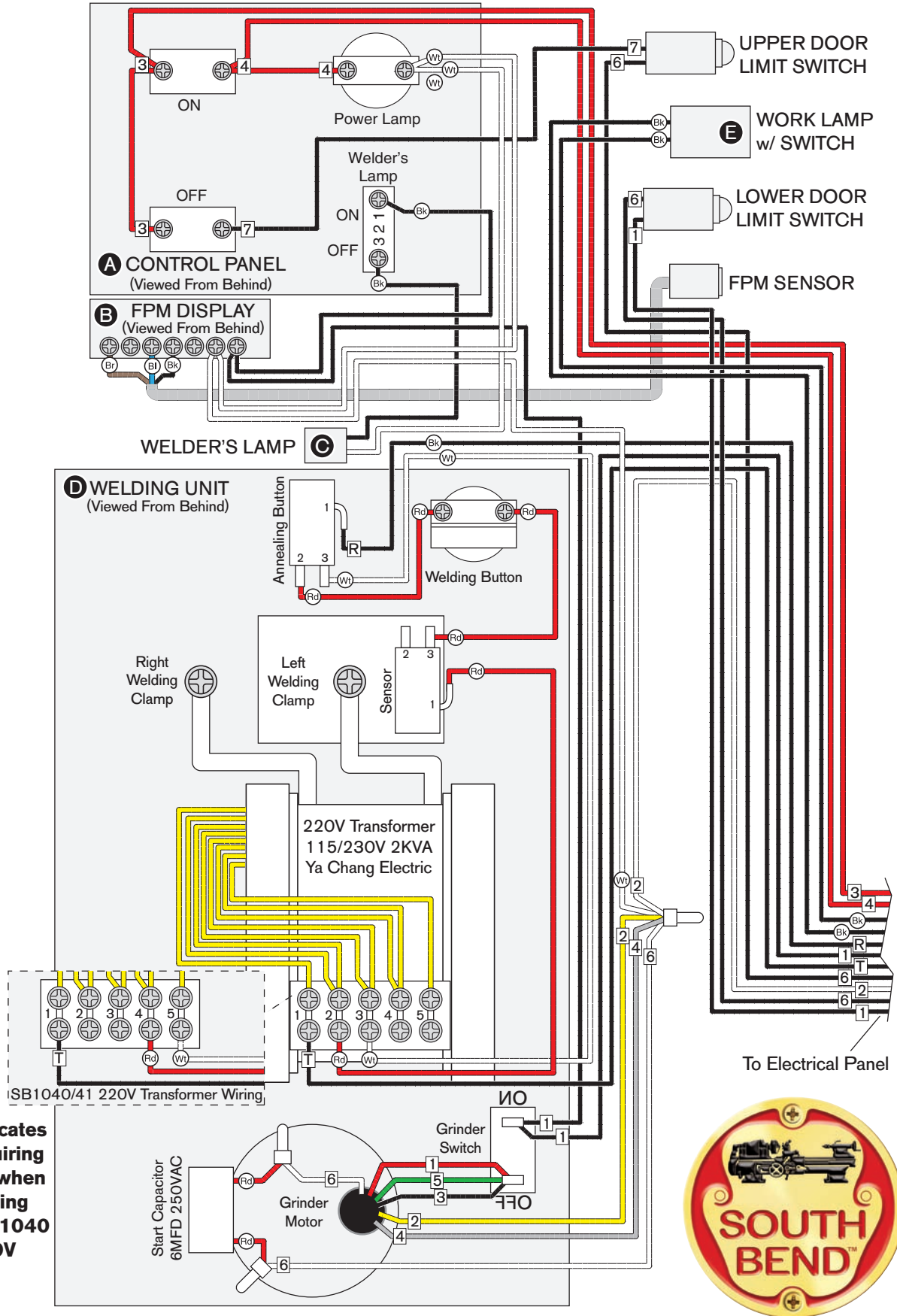

[] Indicates area requiring changes when converting Model SB1040 to 220V



SB1040 110V Electrical Panel, Motor & Cord

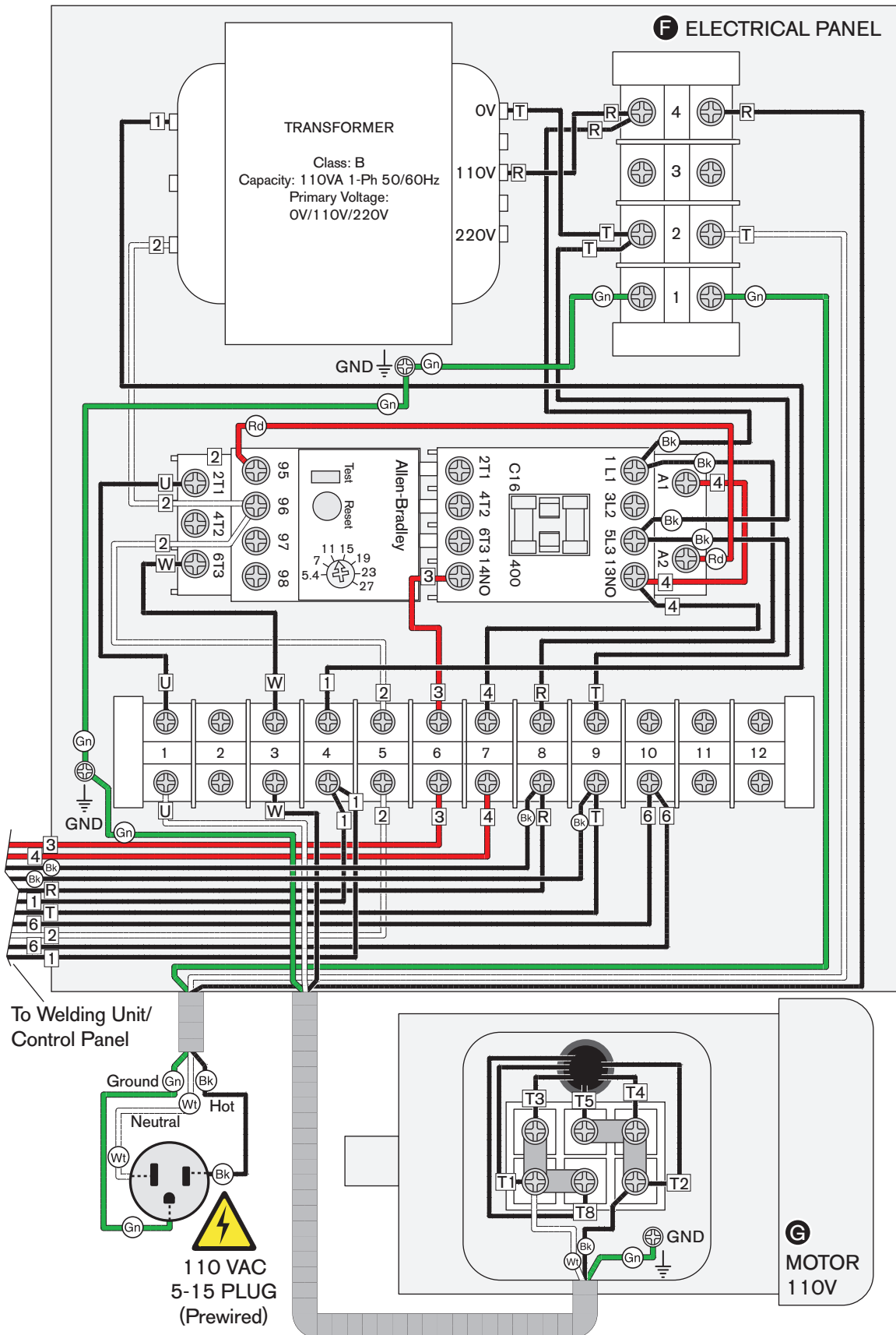

SB1040 220V Electrical Panel, Motor & Cord

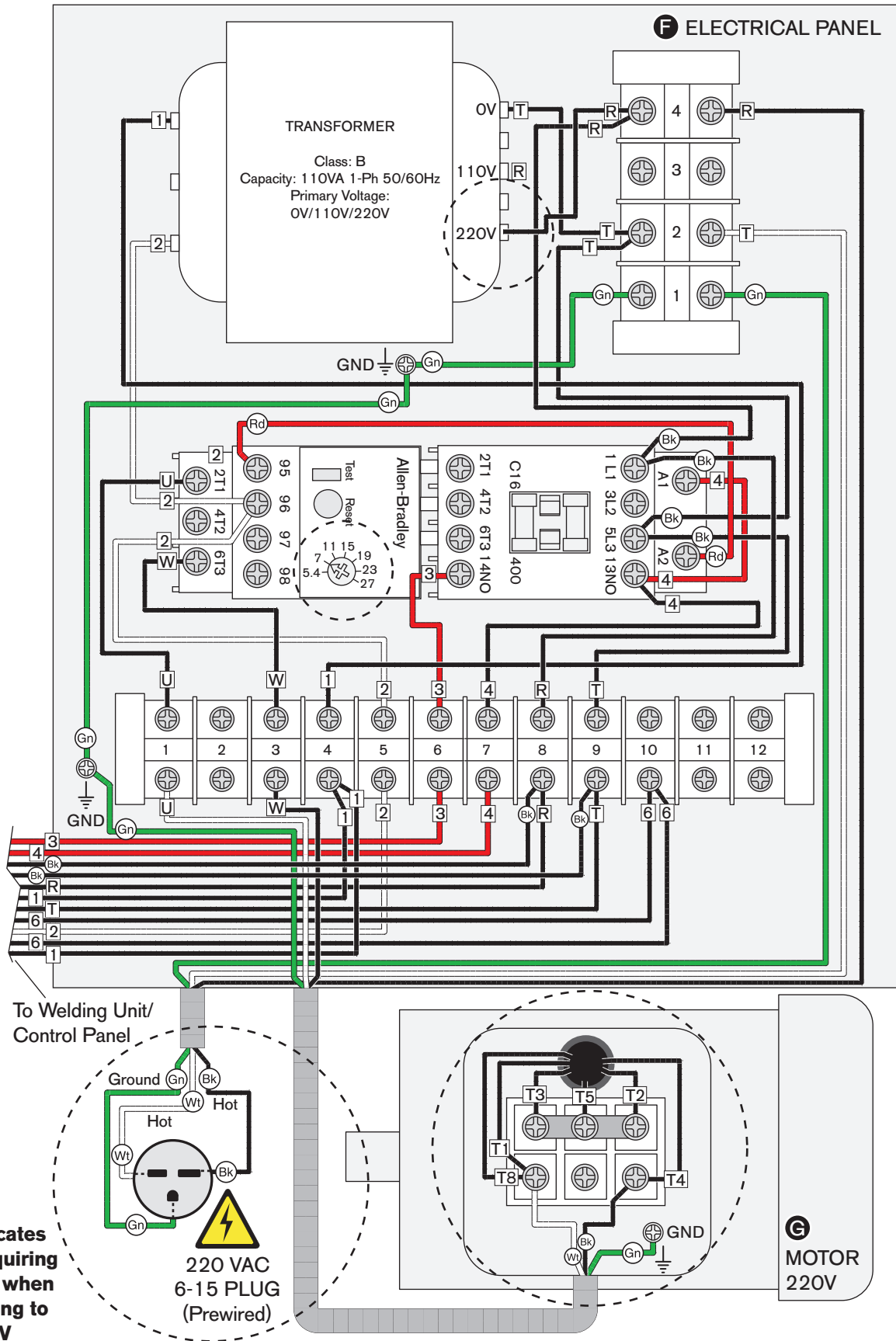

Electrical Component Pictures



Figure 53. Motor and FPM sensor.

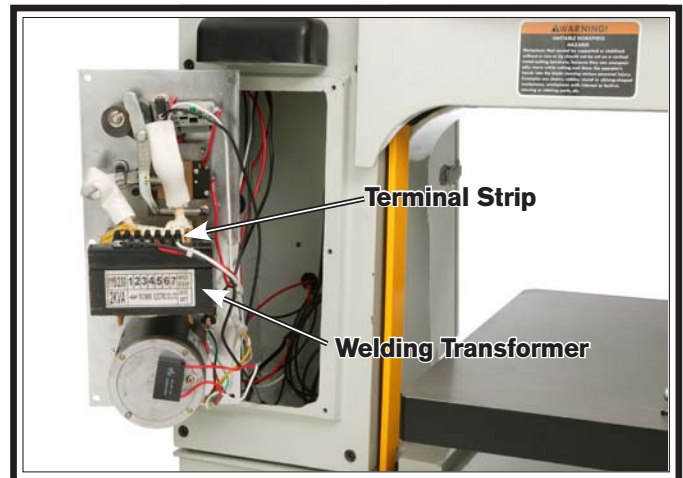

Figure 55. Welding Panel.

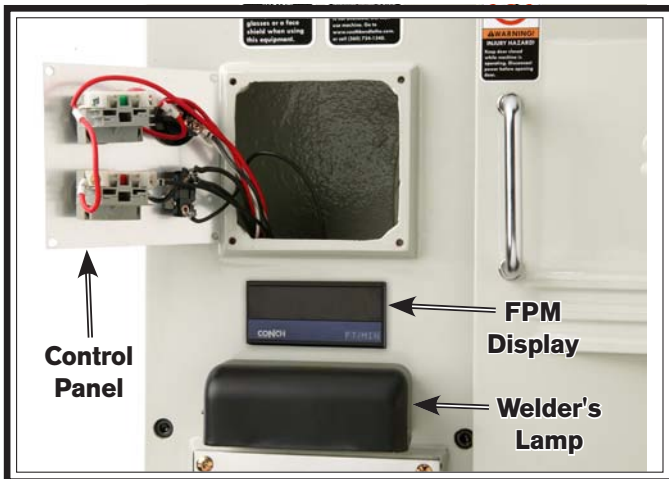
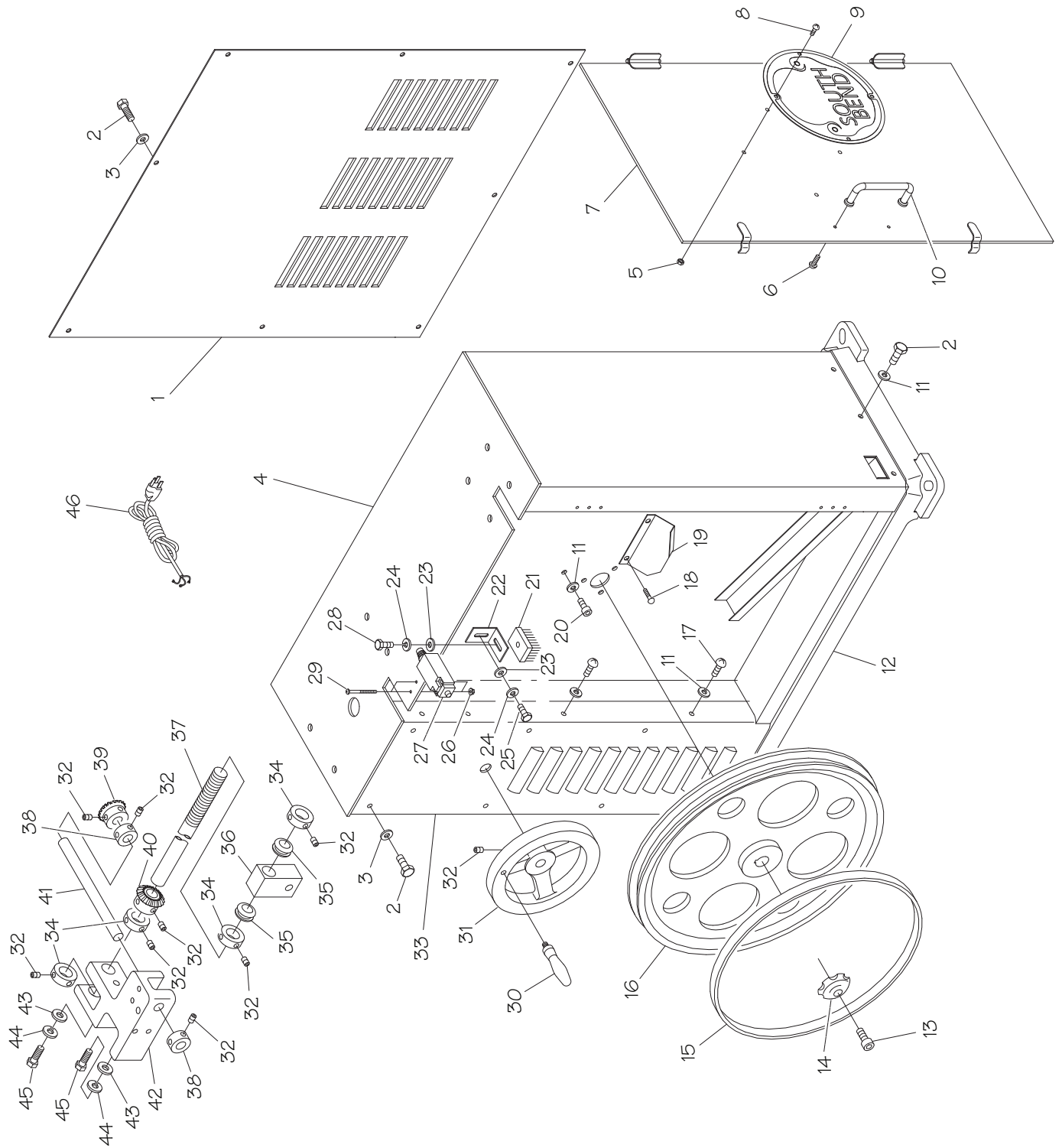

Figure 54. Control Panel, FPM Display & Welder's Lamp.



Figure 56. Electrical Box.

Bottom Frame



Bottom Frame Parts List

REF	PART #	DESCRIPTION
1	PSB1040001	BOTTOM REAR VENTED COVER
2	PB07M	HEX BOLT M8-1.25 X 25
3	PW01M	FLAT WASHER 8MM
4	PSB1040004	BOTTOM FRAME
5	PNO6M	HEX NUT M5-.8
6	PS03M	PHLP HD SCR M6-1 X 8
7	PSB1040007	BOTTOM DOOR
8	PS05M	PHLP HD SCR M5-.8 X 8
9	SB1321	SOUTH BEND NAMEPLATE 203MM
10	PSB1040010	DOOR HANDLE
11	PLW04M	LOCK WASHER 8MM
12	PSB1040012	BASE
13	PCAP31M	CAP SCREW M8-1.25 X 25
14	PSB1040014	BOTTOM WHEEL LOCK NUT
15	PSB1040015	BOTTOM WHEEL RUBBER TIRE
16	PSB1040016	BOTTOM WHEEL
17	PS16M	PHLP HD SCR M8-1.25 X 16
18	PRIV014M	STEEL BLIND RIVET 5 X 20MM
19	PSB1040019	CHIP DEFLECTOR
20	PCAP31M	CAP SCREW M8-1.25 X 25
21	PSB1040021	WHEEL BRUSH
22	PSB1040022	BRUSH BRACKET
23	PW03M	FLAT WASHER 6MM

REF	PART #	DESCRIPTION
24	PLW03M	LOCK WASHER 6MM
25	PB08M	HEX BOLT M6-1 X 20
26	PFNO7M	FLANGE NUT M4-.7
27	PSB1040027	BOTTOM DOOR SAFETY SWITCH
28	PB08M	HEX BOLT M6-1 X 20
29	PS48M	PHLP HD SCR M4-.7 X 50
30	PSB1040030	HANDWHEEL HANDLE
31	PSB1040031	HANDWHEEL
32	PS520M	SET SCREW M8-1.25 X 8
33	PSB1040033	BOTTOM FRONT VENTED COVER
34	PSB1040034	LEADSCREW LOCK COLLAR
35	PSB1040035	RUBBER RING
36	PSB1040036	LEADSCREW END BLOCK
37	PSB1040037	SPEED LEADSCREW
38	PSB1040038	SHAFT LOCK COLLAR
39	PSB1040039	BEVEL GEAR 17T
40	PSB1040040	BEVEL GEAR 17T
41	PSB1040041	SPEED TRANSFER SHAFT
42	PSB1040042	LEADSCREW BRACKET
43	PW04M	FLAT WASHER 10MM
44	PLW06M	LOCK WASHER 10MM
45	PB01M	HEX BOLT M10-1.5 X 30
46	PSB1040046	POWER CORD 14G 3C 5-15 (SB1040)

Drive Train Parts List

REF	PART #	DESCRIPTION
101	PSB1040101	AIR HOSE
102	PSB1040102	AIR HOSE CONNECTOR
103	PB08M	HEX BOLT M6-1 X 20
104	PLW03M	LOCK WASHER 6MM
105	PW03M	FLAT WASHER 6MM
106	P6201ZZ	BALL BEARING 6201ZZ
107	PSB1040107	AIR PUMP BASE
108	PSB1040108	AIR PUMP PULLEY
109	PSS20M	SET SCREW M8-1.25 X 8
110	PVA36	V-BELT A36 (SB1040)
110	PVA37	V-BELT A37 (SB1041)
111	PCAP02M	CAP SCREW M6-1 X 20
112	PSB1040112	AIR PUMP ROTOR
113	PSB1040113	AIR PUMP ROTOR BLADE
114	PSB1040114	AIR PUMP HOUSING
115	PSB1040115	AIR PUMP END CAP
116	PCAP01M	CAP SCREW M6-1 X 16
117	PSB1040117	MOTOR PULLEY
118	PVM26	V-BELT M26
119	PSB1040119	STATIONARY PULLEY PLATE
120	P6202ZZ	BALL BEARING 6202 ZZ
121	PRO3M	EXT RETAINING RING 12MM
122	PSB1040122	GREASE FITTING
123	PSB1040123	MOTOR CORD (SB1040)
123	PSB1041123	MOTOR CORD (SB1041)
124	PSB1040124	MOTOR 1HP 110/220V 1PH (SB1040)
124	PSB1041124	MOTOR 1HP 220V 3PH (SB1041)
124-1	PSB1040124-1	MOTOR FAN COVER (SB1040)
124-1	PSB1041124-1	MOTOR FAN COVER (SB1041)
124-2	PSB1040124-2	MOTOR FAN (SB1040)
124-2	PSB1041124-2	MOTOR FAN (SB1041)
124-3	PSB1040124-3	MOTOR JUNCTION BOX (SB1040)
124-3	PSB1041124-3	MOTOR JUNCTION BOX (SB1041)
124-4	PSB1040124-4	CAPACITOR COVER (SB1040)
124-5	PSB1040124-5	5 CAPACITOR 400M 125V (SB1040)
125	PK21M	KEY 5 X 5 X 23 (SB1040)
125	PK42M	KEY 5 X 5 X 30 (SB1041)
126	PNO3M	HEX NUT M8-1.25
127	PLW04M	LOCK WASHER 8MM
128	PW01M	FLAT WASHER 8MM
129	PB20M	HEX BOLT M8-1.25 X 35
130	PB12M	HEX BOLT M12-1.75 X 55
131	PB140M	HEX BOLT M12-1.75 X 70
132	PSB1040132	LINKING PLATE
133	PW06M	FLAT WASHER 12MM
134	PNO9M	HEX NUT M12-1.75

REF	PART #	DESCRIPTION
135	PSB1040135	PULLEY PLATE SUPPORT ARM
136	PFH05M	FLAT HD SCR M5-.8 X 12
137	PVA43	V-BELT A43
138	PSB1040138	ADJUSTABLE PULLEY PLATE
139	PB14M	HEX BOLT M10-1.5 X 35
140	PB38M	HEX BOLT M12-1.75 X 60
141	PSB1040141	DRIVE CHAIN SUPPORT BRACKET
142	P6205ZZ	BALL BEARING 6205 ZZ
143	PSB1040143	BEARING SEAT
144	PCAP13M	CAP SCREW M8-1.25 X 30
145	PSB1040145	SPROCKET RETAINING HUB
146	PSB1040146	PULLEY PLATE SHAFT
147	PSB1040147	PULLEY PLATE HUB
148	PSB1040148	DRIVE CHAIN
149	PSB1040149	DRIVE CHAIN SPROCKET
150	PCAP11M	CAP SCREW M8-1.25 X 16
151	PLW06M	LOCK WASHER 10MM
152	PK42M	KEY 6 X 6 X 30
153	PSB1040153	DRIVE SPROCKET SHAFT
154	PK169M	KEY 6 X 6 X 45
155	PB26M	HEX BOLT M8-1.25 X 30
157	PSB1040157	PILLOW BLOCK BEARING
158	PSB1040158	PILLOW BLOCK MOUNTING PLATE
159	PK74M	KEY 6 X 6 X 35
160	PB14M	HEX BOLT M10-1.5 X 35
161	PVA47	V-BELT A47
162	PRO8M	EXT RETAINING RING 19MM
163	PSB1040163	IDLER PULLEY
164	PCAP40M	CAP SCREW M8-1.25 X 35
165	PSB1040165	IDLER PULLEY PIVOT BRACKET
166	P6204ZZ	BALL BEARING 6204 ZZ
167	PSB1040167	IDLER SPROCKET SHAFT
168	PSB1040168	SHAFT BLOCK
169	PSB1040169	ADJUSTMENT PULLEY SHAFT
170	PRO5M	EXT RETAINING RING 15MM
171	PR21M	INT RETAINING RING 35MM
172	PSB1040172	ADJUSTMENT PULLEY
173	PR21M	INT RETAINING RING 35MM
174	PRO5M	EXT RETAINING RING 15MM
175	PSB1040175	DRIVE PULLEY SUPPORT BRACKET
176	PSB1040176	DRIVE PULLEY PIVOT BRACKET
177	PSB1040177	DRIVE PULLEY
178	PR25M	INT RETAINING RING 47MM
179	PSB1040179	SUPPORT BASE
180	PSB1040180	MOTOR CORD GROMMET
181	P6202ZZ	BALL BEARING 6202 ZZ

Top Frame

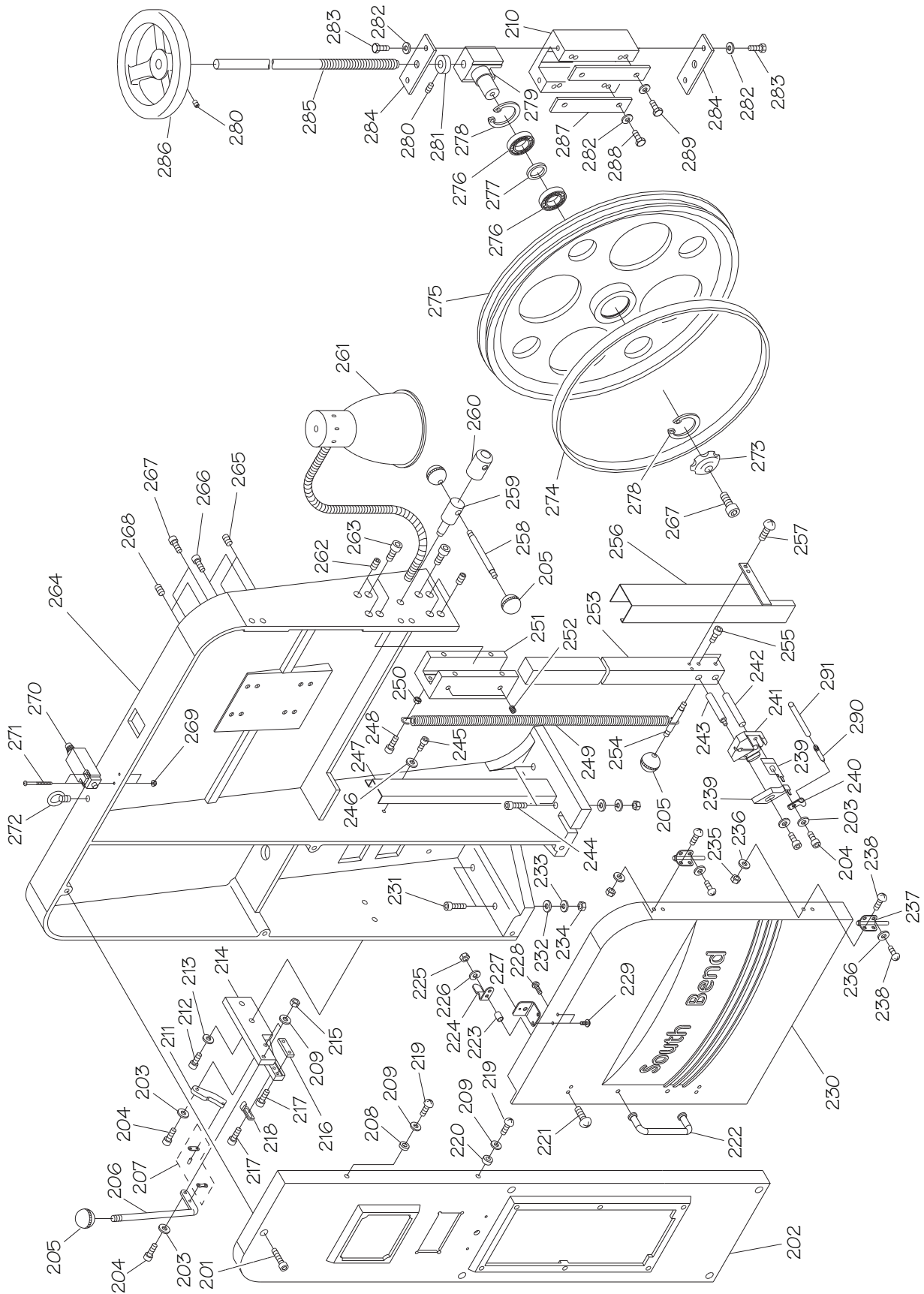

Top Frame Parts List

REF	PART #	DESCRIPTION
201	PCAP40M	CAP SCREW M8-1.25 X 35
202	PSB1040202	BLADE WELDING STATION COVER
203	PW03M	FLAT WASHER 6MM
204	PCAP06M	CAP SCREW M6-1 X 25
205	PSB1040205	ROUND KNOB
206	PSB1040206	BLADE SHEAR LEVER
207	PSB1040207	LOCKING LINK
208	PSB1040208	COVER TOP SPACER
209	PLW04M	LOCK WASHER 8MM
210	PSB1040210	TRACKING BRACKET
211	PSB1040211	UPPER SHEAR BLADE
212	PCAP13M	CAP SCREW M8-1.25 X 30
213	PW01M	FLAT WASHER 8MM
214	PSB1040214	BLADE SHEAR BRACKET
215	PNO1M	HEX NUT M6-1
216	PSB1040216	LOWER SHEAR BLADE
217	PCAP03M	CAP SCREW M5-.8 X 8
218	PSB1040218	ALIGNMENT BRACKET
219	PS04M	PHLP HD SCR M8-1.25 X 20
220	PSB1040220	COVER BOTTOM SPACER
221	PS40M	PHLP HD SCR M5-.8 X 16
222	PSB1040010	TOP DOOR HANDLE
223	PSB1040223	TOP DOOR LATCH SPACER
224	PSB1040224	TOP DOOR LATCH
225	PNO6M	HEX NUT M5-.8
226	PLW01M	LOCK WASHER 5MM
227	PSB1040227	DOOR SAFETY SWITCH PLATE
228	PS11M	PHLP HD SCR M6-1 X 16
229	PS08M	PHLP HD SCR M5-.8 X 12
230	PSB1040230	TOP DOOR
231	PCAP71M	CAP SCREW M10-1.5 X 60
232	PW04M	FLAT WASHER 10MM
233	PLW06M	LOCK WASHER 10MM
234	PNO2M	HEX NUT M10-1.5
235	PNO6M	HEX NUT M5-.8
236	PLW01M	LOCK WASHER 5MM
237	PSB1040237	DOOR HINGE
238	PS40M	PHLP HD SCR M5-.8 X 16
239	PSB1040239	BLADE GUIDE
240	PSB1040240	AIR NOZZLE CLAMP
241	PSB1040241	BLADE GUIDE BRACKET
242	PSB1040242	DOWEL PIN
243	PSB1040243	THREADED PIN
244	PCAP70M	CAP SCREW M10-1.5 X 45
245	PCAP01M	CAP SCREW M6-1 X 16
246	PLW03M	LOCK WASHER 6MM

REF	PART #	DESCRIPTION
247	PSB1040247	RETURN BLADE GUARD
248	PCAP01M	CAP SCREW M6-1 X 16
249	PSB1040249	GUIDE BAR TENSION SPRING
250	PNO1M	HEX NUT M6-1
251	PSB1040251	GUIDE BAR BRACKET
252	PSS14M	SET SCREW M8-1.25 X 12
253	PSB1040253	GUIDE BAR
254	PSB1040254	GUIDE BAR HANDLE
255	PCAP04M	CAP SCREW M6-1 X 10
256	PSB1040256	CUTTING BLADE GUARD
257	PS40M	PHLP HD SCR M5-.8 X 16
258	PSB1040258	DOUBLE-END THREADED STUD
259	PSB1040259	GUIDE BAR LOCK STUD
260	PSB1040260	LOCK STUD COVER
261	PSB1040261	LAMP ASSEMBLY
262	PSS10M	SET SCREW M10-1.5 X 20
263	PCAP13M	CAP SCREW M8-1.25 X 30
264	PSB1040264	TOP FRAME
265	PSS10M	SET SCREW M10-1.5 X 20
266	PCAP40M	CAP SCREW M8-1.25 X 35
267	PCAP13M	CAP SCREW M8-1.25 X 30
268	PSS10M	SET SCREW M10-1.5 X 20
269	PNO4M	HEX NUT M4-.7
270	PSB1040027	TOP DOOR SAFETY SWITCH
271	PS48M	PHLP HD SCR M4-.7 X 50
272	PSB1040272	EYE BOLT
273	PSB1040273	TOP WHEEL LOCK NUT
274	PSB1040274	TOP WHEEL RUBBER TIRE
275	PSB1040275	TOP WHEEL
276	P6205ZZ	BALL BEARING 6205ZZ
277	PSB1040277	THRUST WASHER
278	PR26M	INT RETAINING RING 52MM
279	PSB1040279	BOTTOM WHEEL SHAFT
280	PSS20M	SET SCREW M8-1.25 X 8
281	PSB1040281	LOCK COLLAR
282	PLW04M	LOCK WASHER 8MM
283	PB09M	HEX BOLT M8-1.25 X 20
284	PSB1040284	HORIZONTAL RETAINING PLATE
285	PSB1040285	TENSION LEADSCREW
286	PSB1040286	TENSION HANDWHEEL
287	PSB1040287	VERTICAL RETAINING PLATE
288	PB03M	HEX BOLT M8-1.25 X 16
289	PB03M	HEX BOLT M8-1.25 X 16
290	PSB1040290	AIR NOZZLE
291	PSB1040291	AIR HOSE

Table

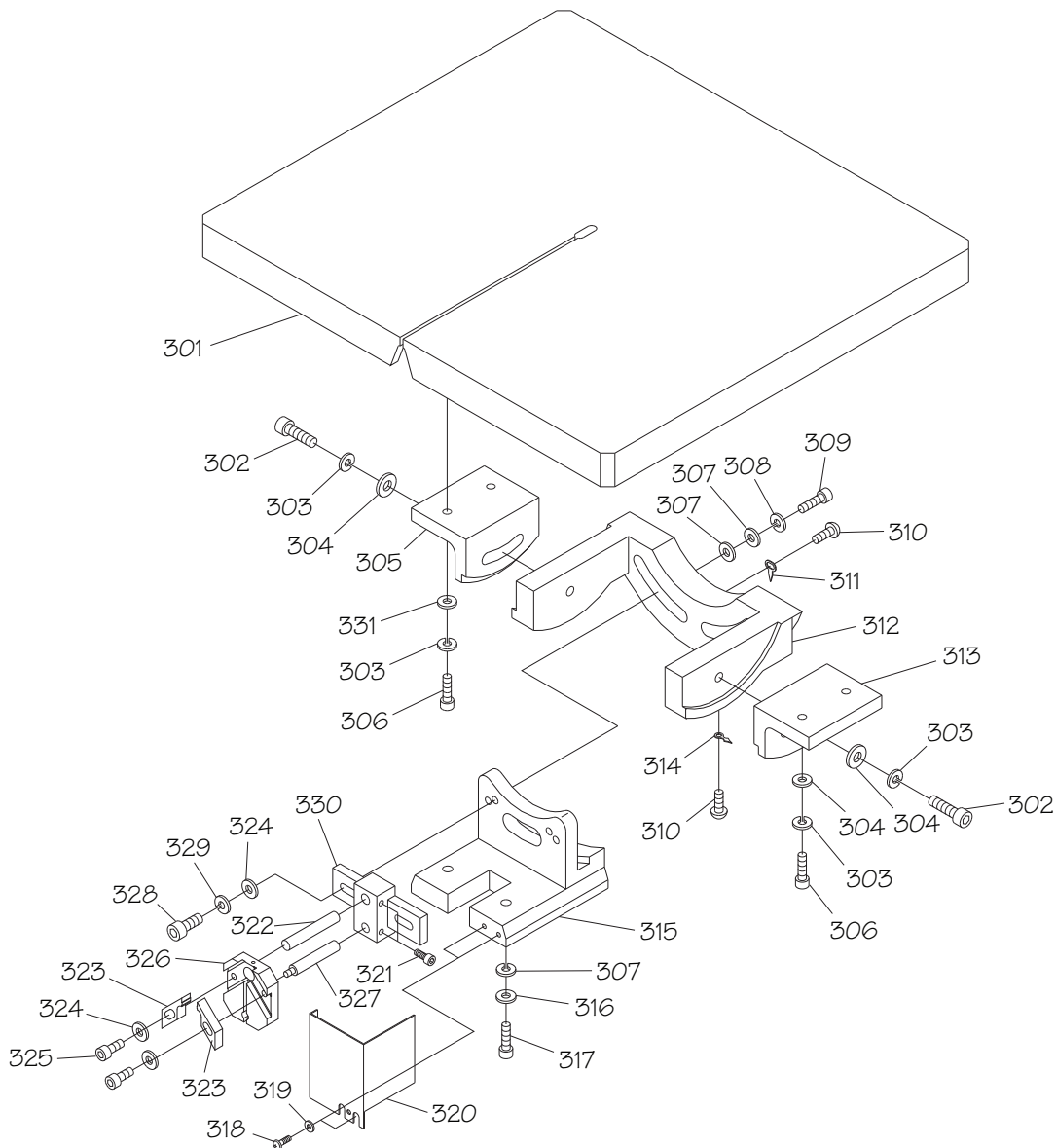

REF	PART #	DESCRIPTION
301	PSB1040301	TABLE
302	PCAP05M	CAP SCREW M8-1.25 X 50
303	PLW04M	LOCK WASHER 8MM
304	PW01M	FLAT WASHER 8MM
305	PSB1040305	LEFT TRUNNION BRACKET
306	PCAP40M	CAP SCREW M8-1.25 X 35
307	PW04M	FLAT WASHER 10MM
308	PLW06M	LOCK WASHER 10MM
309	PCAP90M	CAP SCREW M10-1.5 X 55
310	PS08M	PHLP HD SCR M5-.8 X 12
311	PSB1040311	X-AXIS TILT POINTER
312	PSB1040312	TRUNNION
313	PSB1040313	RIGHT TRUNNION BRACKET W/SCALE
314	PSB1040314	Y-AXIS TILT POINTER
315	PSB1040315	TRUNNION SUPPORT
316	PLW06M	LOCK WASHER 10MM

REF	PART #	DESCRIPTION
317	PCAP72M	CAP SCREW M10-1.5 X 30
318	PS40M	PHLP HD SCR M5-.8 X 16
319	PW02M	FLAT WASHER 5MM
320	PSB1040320	BOTTOM BLADE GUARD
321	PCAP04M	CAP SCREW M6-1 X 10
322	PSB1040242	DOWEL PIN
323	PSB1040239	BLADE GUIDE
324	PW03M	FLAT WASHER 6MM
325	PCAP06M	CAP SCREW M6-1 X 25
326	PSB1040241	BLADE GUIDE BRACKET
327	PSB1040243	THREADED PIN
328	PCAP07M	CAP SCREW M6-1 X 30
329	PLW03M	LOCK WASHER 6MM
330	PSB1040330	BOTTOM BLADE GUIDE SUPPORT
331	PW01M	FLAT WASHER 8MM

Welding Station & Control Panel

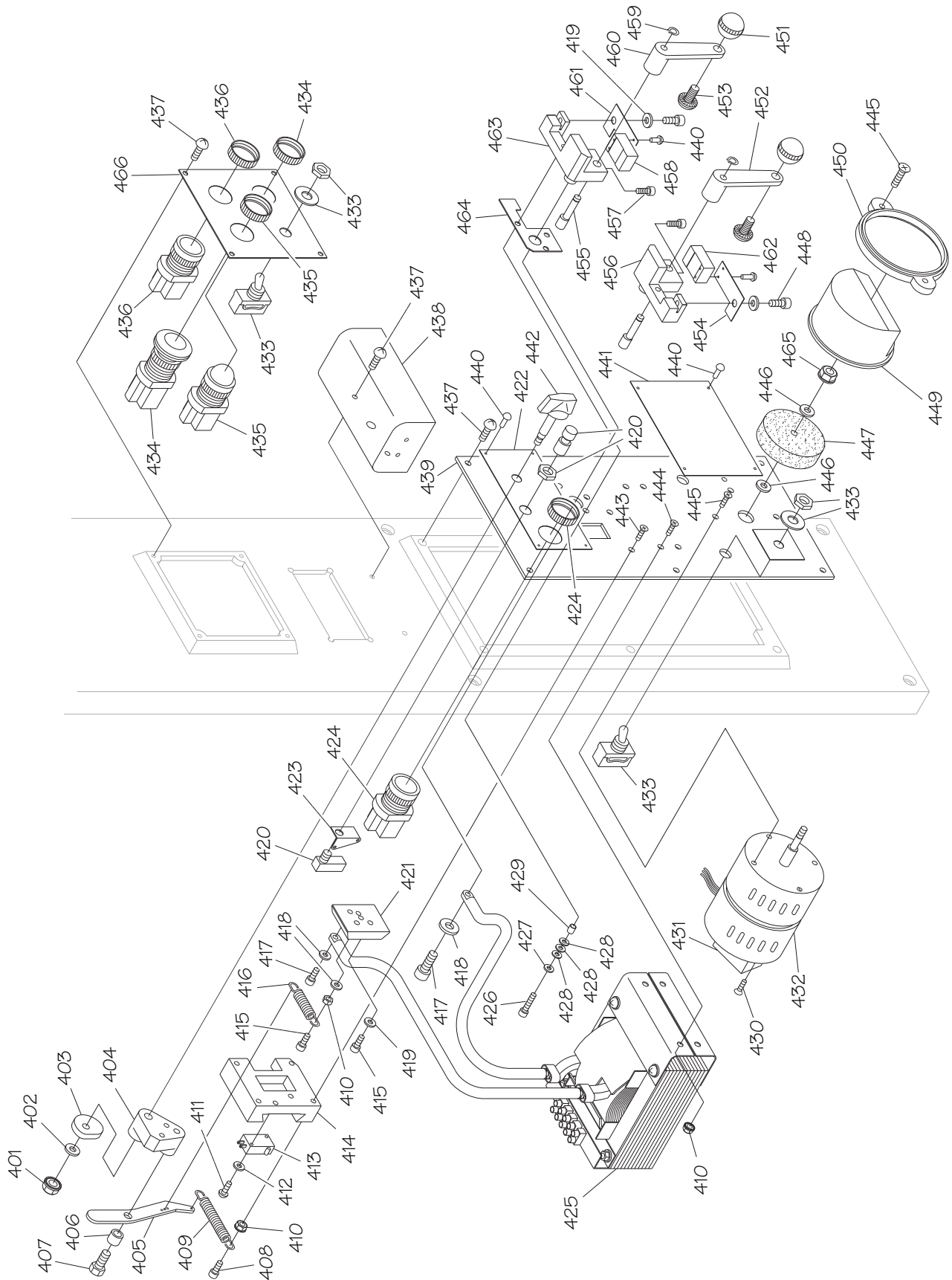

Welding Station & Control Panel Parts List

REF	PART #	DESCRIPTION
401	PNO1M	HEX NUT M6-1
402	PW03M	FLAT WASHER 6MM
403	PSB1021500	CAM
404	PSB1021550	SPRING ARM BRACKET
405	PSB1021503	SPRING ARM
406	PSB1021504	SPACER
407	PB83M	HEX BOLT M6-1 X 16
408	PCAP38M	CAP SCREW M5-.8 X 25
409	PSB1021507	LOWER EXTENSION SPRING
410	PNO6M	HEX NUT M5-.8
411	PS48	PHLP HD SCR 5-40 X 3/4
412	PLW11	LOCK WASHER #5
413	PSB1021511	SWITCH
414	PSB1021512	SLIDE SEAT
415	PCAP38M	CAP SCREW M5-.8 X 25
416	PSB1021514	UPPER EXTENSION SPRING
417	PCAP03M	CAP SCREW M5-.8 X 8
418	PW02M	FLAT WASHER 5MM
419	PLW01M	LOCK WASHER 5MM
420	PSB1021519	ANNEALING BUTTON ASSEMBLY
421	PSB1021518	SLIDE BLOCK
422	PSB1021548	WELDING CONTROL PANEL
423	PSB1021520	ANNEALING BUTTON BRACKET
424	PSB1021521	WELDING BUTTON ASSEMBLY
425	PSB1021526	WELDING TRANSFORMER ASSEMBLY
426	PCAP24M	CAP SCREW M5-.8 X 16
427	PW02M	FLAT WASHER 5MM
428	PSB1021524	INSULATING WASHER 5MM
429	PSB1021525	INSULATING SPACER 5MM
430	PFH78M	FLAT HD SCR M5-.8 X 6
431	PSB1021529	GRINDER MOTOR CAPACITOR
432	PSB1021530	GRINDER MOTOR 1/8HP 110V 1PH
433	PSB1021531	TOGGLE SWITCH ASSEMBLY

REF	PART #	DESCRIPTION
434	PSB1021532	OFF BUTTON ASSEMBLY
435	PSB1021533	POWER LAMP ASSEMBLY
436	PSB1021534	ON BUTTON ASSEMBLY
437	PS09M	PHLP HD SCR M5-.8 X 10
438	PSB1021543	LAMP ASSEMBLY
439	PSB1021545	WELDING PANEL
440	PRV015M	BRASS BLIND RIVET 2 X 6MM
441	PSB1021581	WELDING INSTRUCTION PLATE
442	PSB1021549	PRESSURE KNOB ASSEMBLY
443	PFH39M	FLAT HD SCR M5-.8 X 16
444	PFH05M	FLAT HD SCR M5-.8 X 12
445	PFH07M	FLAT HD SCR M5-.8 X 10
446	PW06	FLAT WASHER 1/4
447	PSB1021577	GRINDING WHEEL 1/4 X 5/8 X 2-1/2
448	PCAP97M	CAP SCREW M5-.8 X 6
449	PSB1021574	GRINDING WHEEL GUARD
450	PSB1021573	GUARD RETAINING RING
451	PSB1021566	ROUND KNOB
452	PSB1021567	LEFT CLAMP LEVER
453	PS16M	PHLP HD SCR M8-1.25 X 16
454	PSB1021570	LEFT CONNECTING PLATE
455	PSB1021556	CAM SHAFT
456	PSB1021571	LEFT ELECTRODE
457	PCAP33M	CAP SCREW M5-.8 X 12
458	PSB1021559	RIGHT LOWER JAW
459	PR73M	EXT RETAINING RING 5MM
460	PSB1021565	RIGHT CLAMP LEVER
461	PSB1021560	RIGHT CONNECTING PLATE
462	PSB1021569	LEFT LOWER JAW
463	PSB1021557	RIGHT ELECTRODE
464	PSB1021555	JAW INSULATOR
465	PNO5	HEX NUT 1/4-20
466	PSB1021536	SAW CONTROL PANEL

Digital Tachometer System

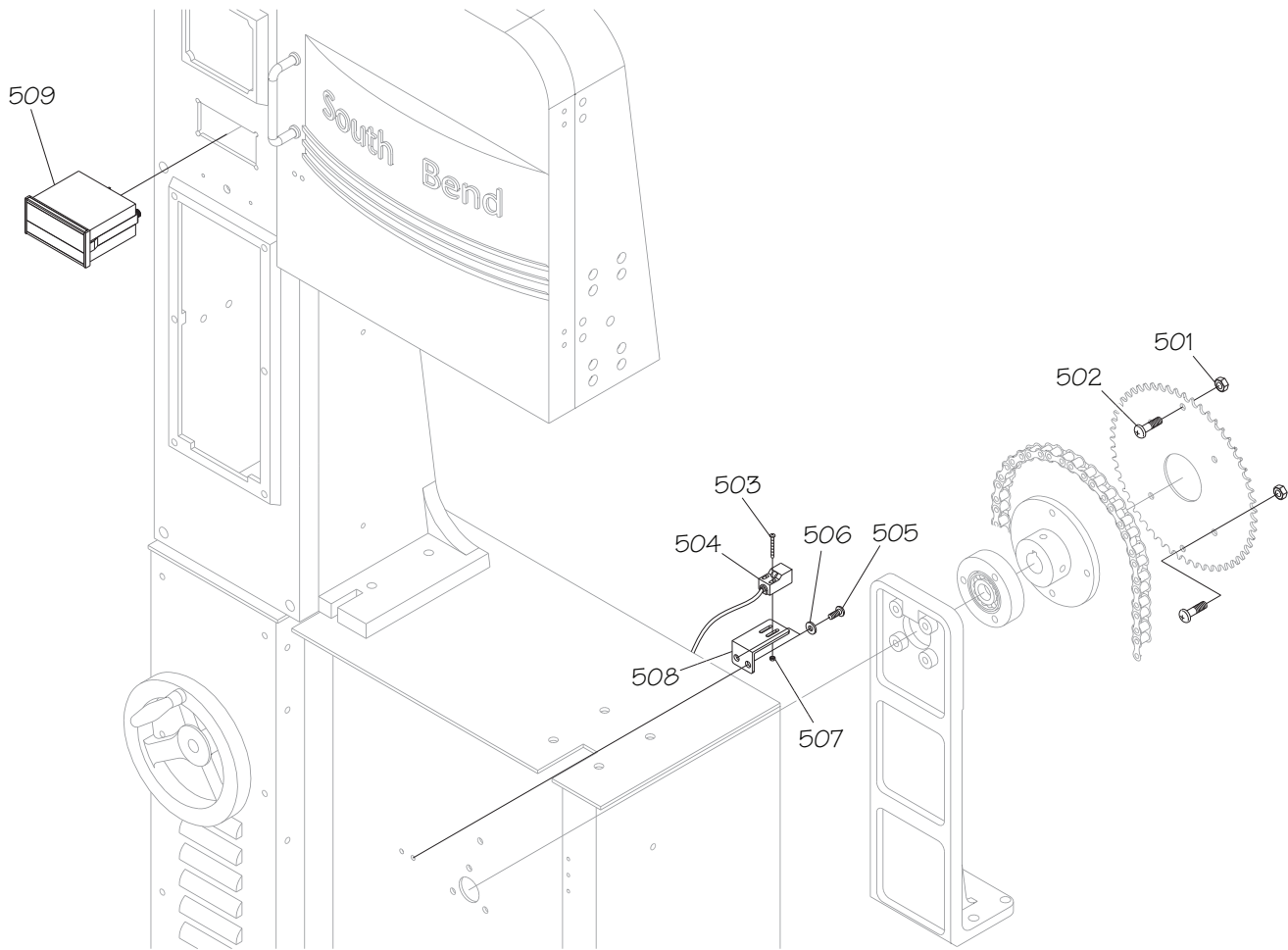

REF	PART #	DESCRIPTION
501	PN03M	HEX NUT M8-1.25
502	PS16M	PHLP HD SCR M8-1.25 X 16
503	PS113M	PHLP HD SCR 5-40 X 1
504	PSB1040504	TACHOMETER SENSOR
505	PS68M	PHLP HD SCR M6-1 X 10

REF	PART #	DESCRIPTION
506	PW03M	FLAT WASHER 6MM
507	PN28	HEX NUT 5-40
508	PSB1040508	SENSOR BRACKET
509	PSB1040509	DIGITAL TACHOMETER

Electrical Cabinet

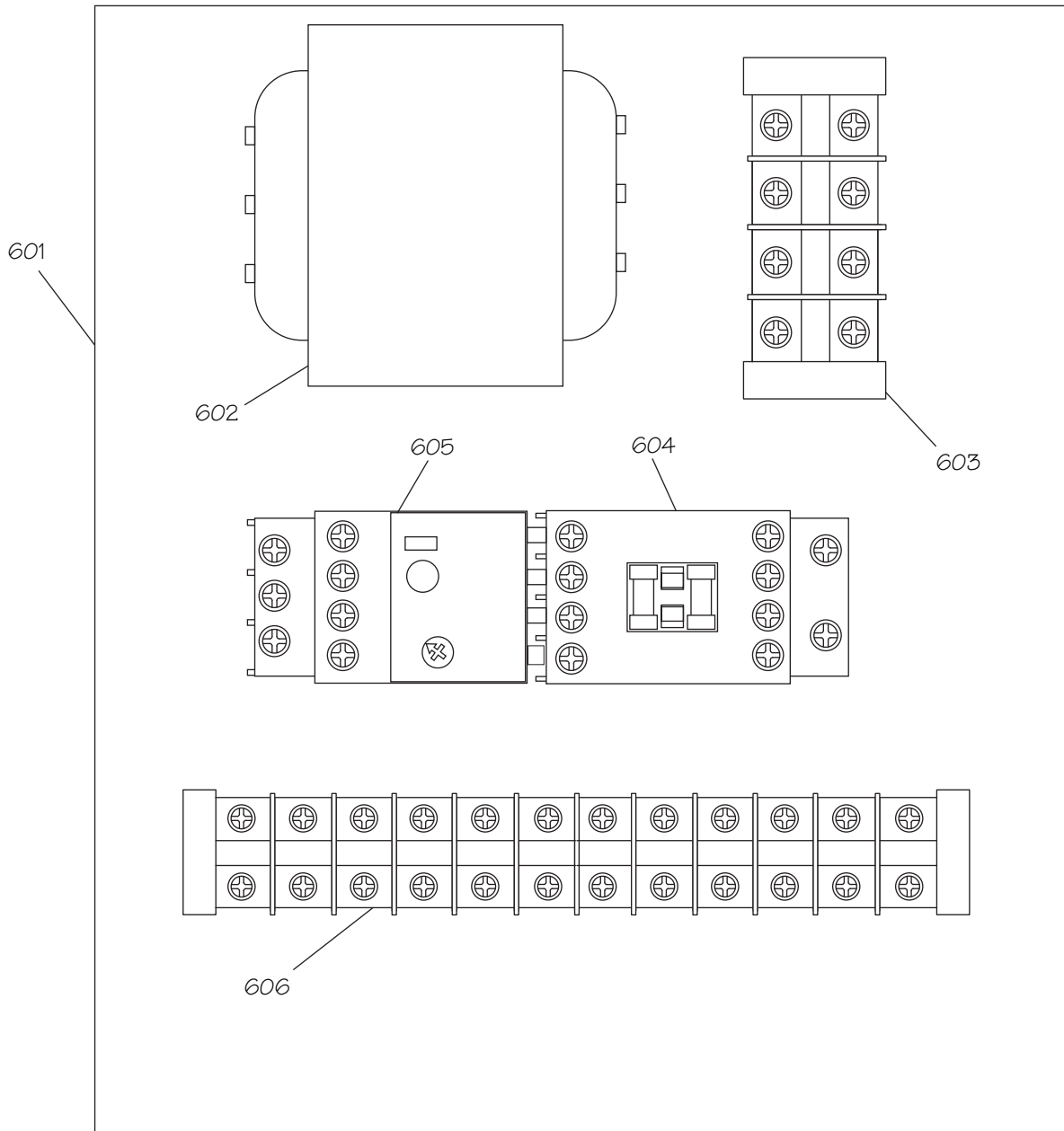

REF	PART #	DESCRIPTION
601	PSB1040601	ELECTRICAL BACKBOARD
602	PSB1040602	TRANSFORMER YA CHANG 220V 1A
603	PSB1040603	TERMINAL BLOCK 4 POST
604	PSB1040604	CONTACTOR AB 100-C16-400 110V (SB1040)

REF	PART #	DESCRIPTION
604	PSB1041604	CONTACTOR AB 100-C09-400 110V (SB1041)
605	PSB1040605	OL RELAY AB 193-EEEB 5.4 - 27A (SB1040)
605	PSB1041605	OL RELAY AB 193-EEDB 3.2 - 16A (SB1041)
606	PSB1040606	TERMINAL BLOCK 12 POST

Circle Cutting Jig

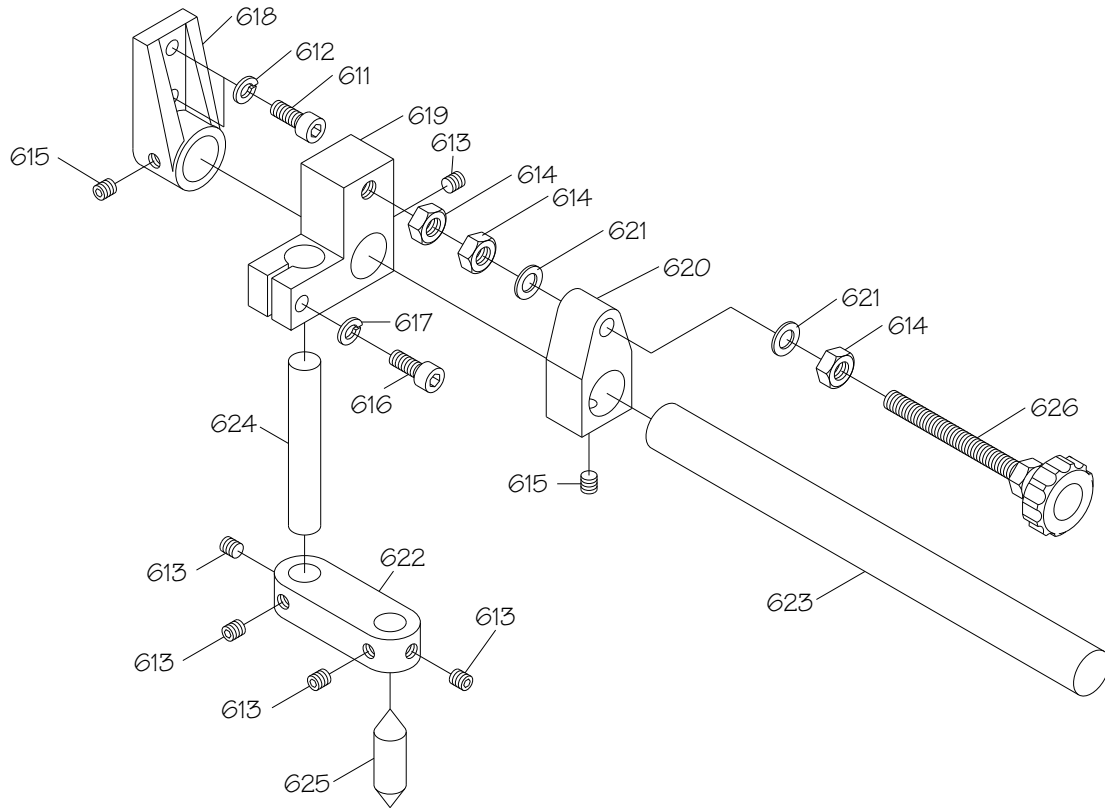

REF	PART #	DESCRIPTION
611	PCAP31M	CAP SCREW M8-1.25 X 25
612	PLW04M	LOCK WASHER 8MM
613	PSS20M	SET SCREW M8-1.25 X 8
614	PNO2M	HEX NUT M10-1.5
615	PSS20M	SET SCREW M8-1.25 X 8
616	PCAP13M	CAP SCREW M8-1.25 X 30
617	PLW04M	LOCK WASHER 8MM
618	PSB1040618	MOUNTING BLOCK

REF	PART #	DESCRIPTION
619	PSB1040619	CLAMPING BLOCK
620	PSB1040620	ADJUSTING BLOCK
621	PW04M	FLAT WASHER 10MM
622	PSB1040622	POINTER ADJUSTING BLOCK
623	PSB1040623	CIRCLE JIG ROD
624	PSB1040624	POINTER ROD
625	PSB1040625	CENTER POINT
626	PSB1040626	ADJUSTING KNOB M10-1.5 X 170

Machine Labels

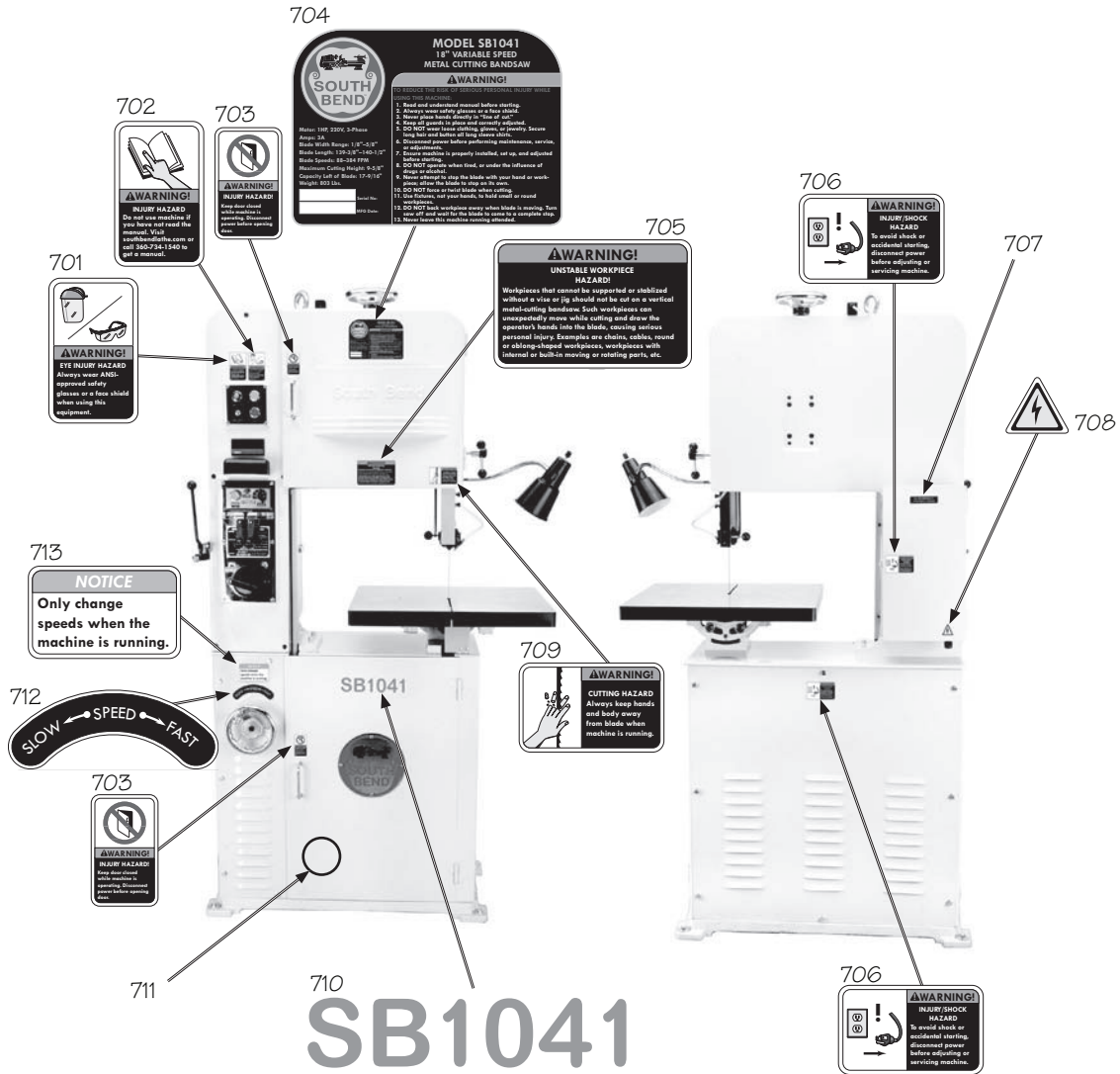

SB1041

REF	PART #	DESCRIPTION
701	PSBLABEL09VL	EYE INJURY HAZARD LABEL
702	PSBLABEL01VL	READ MANUAL LABEL
703	PSBLABEL14VS	CLOSE DOOR WARNING LABEL
704	PSB1040704	MACHINE ID LABEL (SB1040)
704	PSB1041704	MACHINE ID LABEL (SB1041)
705	PSB1040705	UNSTABLE WORKPIECE LABEL
706	PSBLABEL02HL	SHOCK HAZARD LABEL
707	PSBLABEL18	ALLEN BRADLEY CONTROLS LABEL

REF	PART #	DESCRIPTION
708	PSBLABEL15L	ELECTRICITY LABEL
709	PSBLABEL14HL	CUTTING HAZARD LABEL
710	PSB1040710	MODEL NUMBER LABEL (SB1040)
710	PSB1041710	MODEL NUMBER LABEL (SB1041)
711	PSBPAINTO1	SB GRAY TOUCH-UP PAINT
712	PSB1040712	SPEED DIRECTION LABEL
713	PSB1040713	CHANGE SPEED NOTICE LABEL

⚠️ WARNING

The safety labels provided with your machine are used to make the operator aware of the machine hazards and ways to prevent injury. The owner of this machine **MUST** maintain the original location and readability of these safety labels. If any label is removed or becomes unreadable, **REPLACE** that label before using the machine again. Contact South Bend Lathe Co. at (360) 734-1540 or www.southbendlathe.com to order new labels.

Warranty

This quality product is warranted by South Bend Lathe Company to the original buyer for one year from the date of purchase. This warranty does not apply to consumable parts, or defects due to any kind of misuse, abuse, negligence, accidents, repairs, alterations or lack of maintenance. We do not reimburse for third party repairs. In no event shall we be liable for death, injuries to persons or property, or for incidental, contingent, special or consequential damages arising from the use of our products.

We do not warrant or represent that this machine complies with the provisions of any law, act, code, regulation, or standard of any domestic or foreign government, industry, or authority. In no event shall South Bend's liability under this warranty exceed the original purchase price paid for this machine. Any legal actions brought against South Bend Lathe Company shall be tried in the State of Washington, County of Whatcom.

This is the sole written warranty for this machine. Any and all warranties that may be implied by law, including any merchantability or fitness, for any purpose, are hereby limited to the duration of this warranty. To take advantage of this warranty, contact us by mail or phone to give us the details of the problem you are having.

Thank you for your business and continued support.



South Bend Lathe Co.
P.O. Box 2027
Bellingham, WA 98227

PHONE: (360) 734-1540 (Administrative Offices)

FAX: (360) 676-1075 (International)

FAX: (360) 734-1639 (USA only)

southbendlathe.com

