

# Grizzly®



## MODEL T10001 5 Shelf Unit INSTRUCTION SHEET

### Specifications

Overall Size ..... 28½"W x 10½"D x 71"T  
Shelf Size .....28¼"W x 10¼"D  
Number of Shelves ..... 5  
Overall Weight Capacity.....400 lbs.  
Weight Capacity Per Shelf..... 80 lbs.

### Inventory

|                          | Qty |
|--------------------------|-----|
| A. Support Bracket ..... | 8   |
| B. Nut .....             | 56  |
| C. Bolt .....            | 56  |
| D. Rail .....            | 4   |
| E. Shelf .....           | 5   |
| F. Foot .....            | 4   |

### Assembly

After unpacking your Model T10001 shelving unit, perform an inventory of the parts. You will need a #3 Phillips screwdriver and a 10mm wrench to assemble the shelves.

Begin by loosely assembling the shelf unit with the supplied nuts and bolts. Attach one side of the rails, then the other, making sure that the shelves are parallel to one another as shown in the illustration on **Page 2**. Once the shelf unit is assembled, attach the feet and place it upright on a flat level surface, then tighten all of the bolts.



*If you need help with your new item, call our Tech Support at: (570) 546-9663.*

# T10001 Parts Breakdown and List

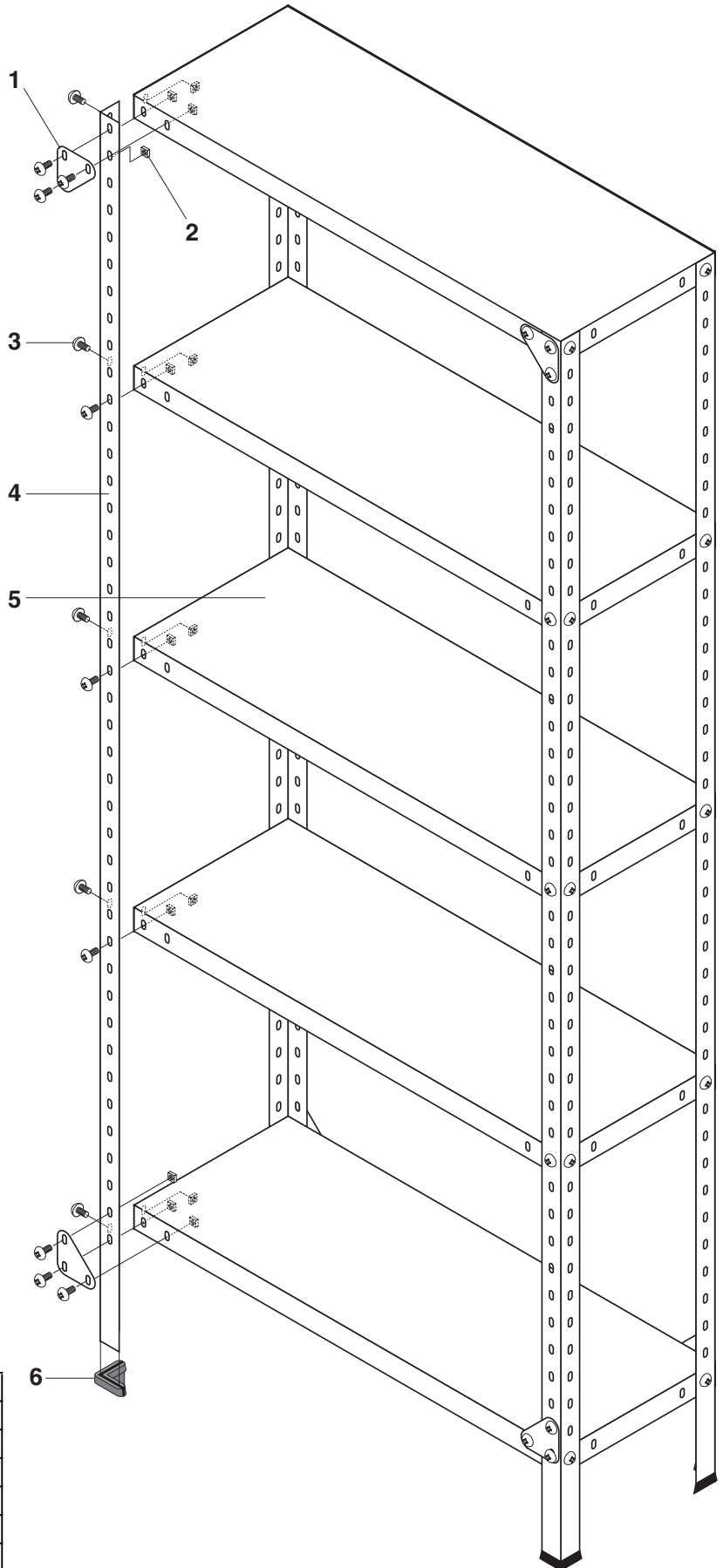
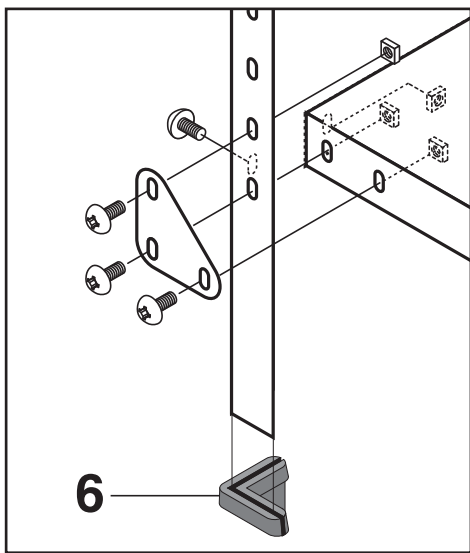
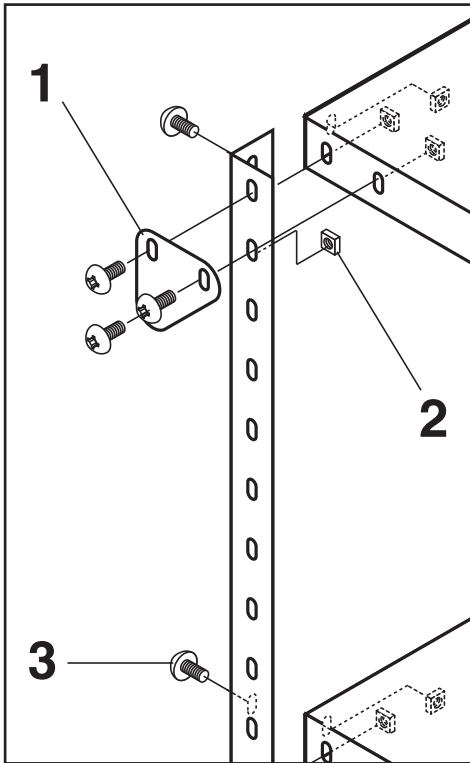

## T10001 Parts List

| REF | PART #     | DESCRIPTION           |
|-----|------------|-----------------------|
| 1   | PT10001001 | SUPPORT BRACKET       |
| 2   | PSN02M     | SQUARE NUT M6-1       |
| 3   | PS68M      | PHLP HD SCR M6-1 X 10 |
| 4   | PT10001004 | RAIL                  |
| 5   | PT10001005 | SHELF                 |
| 6   | PT10001006 | FOOT                  |
| 7   | PT10001007 | COMPLETE HARDWARE BAG |

