

Cabinet, Motor & Main Table Breakdown

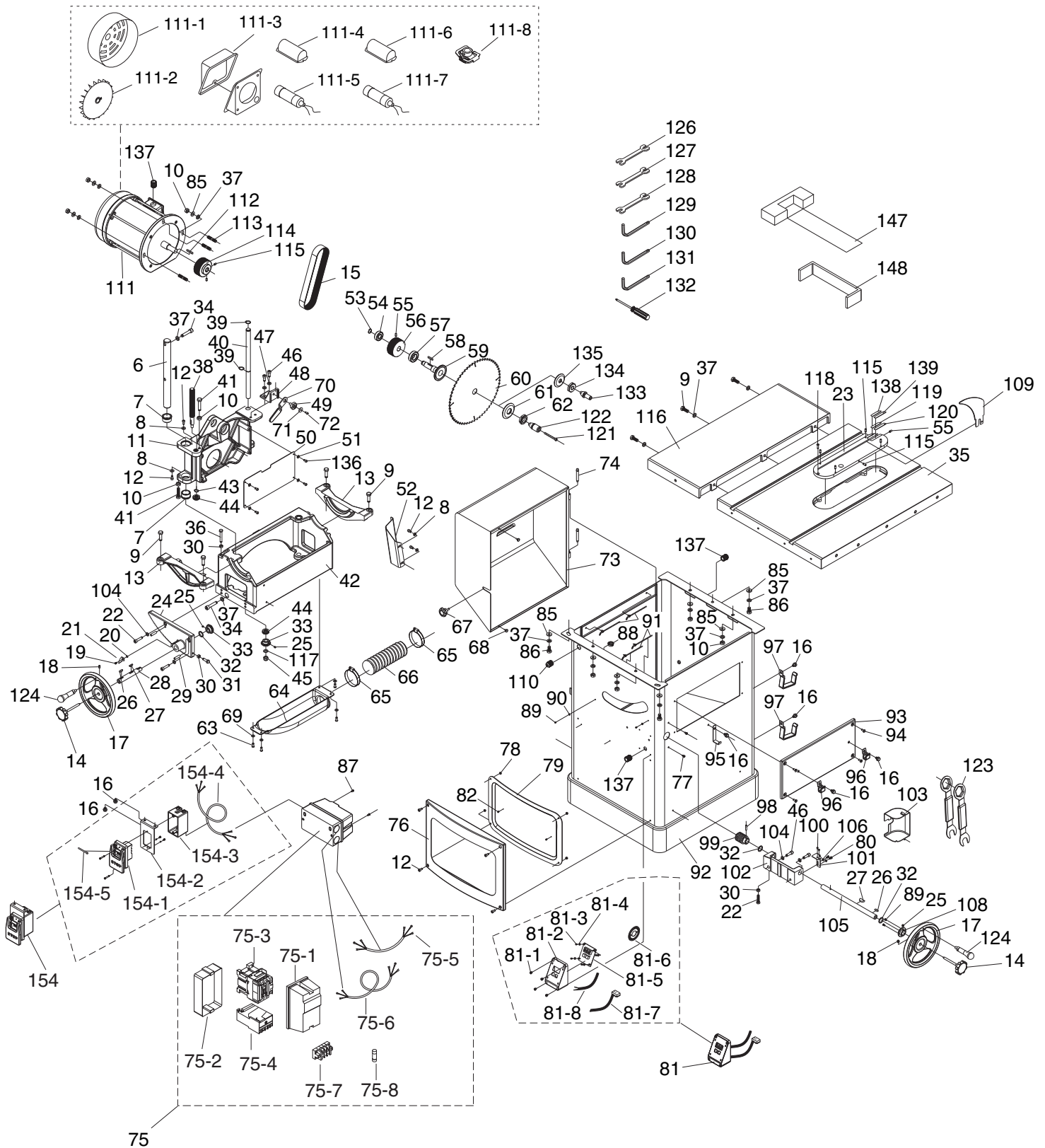

Cabinet, Motor & Main Table Parts List

REF PART #	DESCRIPTION
6	P0605X006 SHAFT
7	P0605X007 BUSHING
8	PW03M FLAT WASHER 6MM
9	PB14M HEX BOLT M10-1.5 X 35
10	PN02M HEX NUT M10-1.5
11	P0605X011 MOTOR MOUNTING BRACKET
12	PSB26M CAP SCREW M6-1 X 12
13	P0605X013 TRUNNION SLIDE
14	P0605X014 HANDWHEEL LOCK KNOB
15	P0605X015 FLAT BELT 250J-12
16	PFB15M FLANGE BOLT M8-1.25 X 12
17	P0605X017 HANDWHEEL
18	PSS17 SET SCREW 5/16-18 X 5/16
19	PSBS09M BUTTON HD CAP SCR M6-1 X 12
20	PTLW05M EXT TOOTH WASHER 6MM
21	P0605X021 POINTER
22	PSB13M CAP SCREW M8-1.25 X 30
23	P0605X023 TABLE INSERT
24	P0605X024 PLATE
25	PSS07M SET SCREW M5-.8 X 5
26	PK14M KEY 5 X 5 X 18
27	P0605X027 WOODRUFF KEY 22 X 5 X 6.5
28	P0605X028 SHAFT
29	PRP65M ROLL PIN 8 X 20
30	PN03M HEX NUT M8-1.25
31	PB07M HEX BOLT M8-1.25 X 25
32	P0605X032 FLAT WASHER 19MM
33	P0605X033 BEVEL GEAR
34	PSB143M CAP SCREW M10-1.5 X 50
35	P0605X035 TABLE
36	PB30M HEX BOLT M8-1.25 X 55
37	PLW06M LOCK WASHER 10MM
38	P0605X038 ACME SCREW
39	P0605X039 EXT RET RING 18MM
40	P0605X040 SHAFT
41	PB31M HEX BOLT M10-1.5 X 40
42	P0605X042 TRUNNION
43	PR54M INT RETAINING RING 15MM
44	P51102 THRUST BEARING 51102
45	PLN10M LOCK NUT M10-1.25
46	PSB31M CAP SCREW M8-1.25 X 25
47	PW01M FLAT WASHER 8MM

REF PART #	DESCRIPTION
48	P0605X048 SPLITTER MOUNTING BRACKET
49	P0605X049 SPECIAL BOLT
50	P0605X050 BELT COVER PLATE
51	PLW03M LOCK WASHER 6MM
52	P0605X052 DEFLECTOR PLATE
53	PR18M EXT RETAINING RING 17MM
54	P6203 BALL BEARING 6203ZZ
55	PSS91M SET SCREW M6-1 X 14
56	P0605X056 PULLEY
57	P6005 BALL BEARING 6005ZZ
58	PK131M KEY 5 X 5 X 28
59	P0605X059 SHAFT
60	P0605X060 BLADE
61	P0605X061 BLADE WASHER
62	P0605X062 BLADE NUT
63	PSB01M CAP SCREW M6-1 X 16
64	P0605X064 DUST CHUTE
65	P0605X065 HOSE CLAMP
66	P0605X066 DUST CHUTE HOSE 63MM x 1000MM
67	P0605X067 LOCK KNOB M6-1 X 17
68	P0605X068 BLOCK
69	PW03M FLAT WASHER 6MM
70	P0605X070 LEVER
71	PW02M FLAT WASHER 5MM
72	PSBS06M BUTTON HD CAP SCR M5-.8 X 12
73	P0605X073 MOTOR COVER
74	P0605X073 PIN 7 X 54
75	P0605X075 MAG SWITCH 5HP-1PH, 23A (G0605X)
75	P0606X075 MAG SWITCH 220V-3PH, 22A (G0606X)
75-1	P0605X075-1 MAG SWITCH FRONT COVER (G0605X)
75-1	P0606X075-1 MAG SWITCH FRONT COVER (G0606X)
75-2	P0605X075-2 MAG SWITCH BACK COVER (G0605X)
75-2	P0606X075-2 MAG SWITCH BACK COVER (G0606X)
75-3	P0605X075-3 CONTACTOR (G0605X)
75-3	P0606X075-3 CONTACTOR (G0606X)
75-4	P0605X075-4 THERMAL OVERLOAD RELAY (G0605X)
75-4	P0606X075-4 THERMAL OVERLOAD RELAY (G0606X)
75-5	P0605X075-5 MOTOR CORD 12AWG X 3C
75-5	P0606X075-5 MOTOR CORD 12AWG X 4C
75-6	P0605X075-6 POWER CORD 12AWG X 3C
75-6	P0606X075-6 POWER CORD 12AWG X 4C
75-7	P0606X075-7 TRANSFORMER (G0606X)



REF	PART #	DESCRIPTION
75-8	P0606X075-8	FUSE (G0606X)
76	P0605X076	FRONT COVER
77	PHTEK5M	TAP SCREW M4 X 12
78	PN06M	HEX NUT M5-.8
79	P0605X079	PLATE
80	PS05M	PHLP HD SCR M5-.8 X 8
81	P0605X080	DIGITAL READOUT ASSEMBLY
81-1	PS05M	PHLP HD SCR M5-.8 X 8
81-2	P0605X081-2	DIGITAL READOUT COVER
81-3	PS79M	PHLP HD SCR M3-.5 X 8
81-4	PW07M	FLAT WASHER 3MM
81-5	P0605X081-5	CIRCUIT BOARD
81-6	P0605X081-6	SENSOR PLATE
81-7	P0605X081-7	DATA CORD (SENSOR TO READOUT)
81-8	P0605X081-8	DIGITAL RDT. CORD 18AWG X 2C X 500MM (MAG SWITCH TO DIGITAL READOUT)
82	PS79M	PHLP HD SCR M3-.5 X 8
85	PW04M	FLAT WASHER 10MM
86	PB74M	HEX BOLT M10-1.5 X 20
87	P0605X087	NYLON SCREW 3/16-24 X 1/2
88	P0605X088	STRAIN RELIEF
89	PS17M	PHLP HD SCR M4-.7 X 6
90	PW05M	FLAT WASHER 4MM
91	P0605X091	CHAIN
92	P0605X092	BODY
93	P0605X093	RIGHT ACCESS PANEL
94	PFH40M	FLAT HD SCR M6-1 X 15
95	P0605X095	WRENCH MOUNTING BRACKET
96	P0605X096	MITER GAUGE MOUNTING BRACKET
97	P0605X097	FENCE RESTING BRACKET
98	PRP27M	ROLL PIN 5 X 28
99	P0605X099	SHAFT
100	PHTEK30M	TAP SCREW M3 X 6
101	P0605X101	"L" PLATE
102	P0605X102	BLADE TILT SHAFT BRACKET
103	P0605X103	COVER
104	PLW04M	LOCK WASHER 8MM
105	P0605X105	HANDWHEEL SHAFT
106	PW02M	FLAT WASHER 5MM
108	P0605X108	SPECIAL RING 19MM
109	P0605X109	RIVING KNIFE
110	P0605X110	STRAIN RELIEF
111	P0605X111	MOTOR 5HP, 1 PHASE (G0605X)
111	P0606X111	MOTOR 7.5HP, 3 PHASE (G0606X)
111-1	P0605X111-1	MOTOR FAN COVER (G0605X)

REF	PART #	DESCRIPTION
111-1	P0606X111-1	MOTOR FAN COVER (G0606X)
111-2	P0605X111-2	MOTOR FAN (G0605X)
111-2	P0606X111-2	MOTOR FAN (G0606X)
111-3	P0605X111-3	JUNCTION BOX (G0605X)
111-3	P0606X111-3	JUNCTION BOX (G0606X)
111-4	P0605X111-4	RUN CAPACITOR COVER (G0605X)
111-5	P0605X111-5	R. CAPACITOR 80MFD/ 250VAC (G0605X)
111-6	P0605X111-6	START CAPACITOR COVER (G0605X)
111-7	P0605X111-7	S. CAPACITOR 600MFD/125VAC (G0605X)
111-8	P0605X111-8	CENTRIFUGAL SWITCH (G0605X)
112	PK02M	KEY 5 X 5 X 40
113	P0605X113	SPECIAL MOTOR BOLT
114	P0605X114	MOTOR PULLEY
115	PSS01M	SET SCREW M6-1 X 10
116	P0605X116	EXTENSION WING
117	PW04M	FLAT WASHER 10MM
118	PFH54M	FLAT HD SCR M5-.8 X 20
119	P0605X119	LEFT TAPE
120	P0605X120	RIGHT TAPE
121	PSB49M	CAP SCREW M6-1 X 60
122	P0605X122	SPINDLE 1"
123	P0605X123	ARBOR WRENCH
124	P0605X124	HANDWHEEL HANDLE
126	PWR810	WRENCH 8 X 10
127	PWR1113	WRENCH 11 X 13
128	PWR1719	WRENCH 17 X 19
129	PAW04M	HEX WRENCH 4MM
130	PAW05M	HEX WRENCH 5MM
131	PAW06M	HEX WRENCH 6MM
132	P0605X132	PHLP HEAD SCREWDRIVER #1
133	P0605X133	SHAFT 5/8"
134	P0605X134	NUT 5/8-18
135	P0605X135	ARBOR FLANGE
136	PSBS09M	BUTTON HD CAP SCR M6-1 X 12
137	P0605X137	STRAIN RELIEF
138	P0605X138	LEFT PLATE
139	P0605X139	RIGHT PLATE
147	P0605X147	RAIL "T" PLATE
148	P0605X148	RAIL "U" PLATE
154	P0605X154	ON/OFF SWITCH ASSEMBLY
154-1	P0605X154-1	ON/OFF PUSH BUTTON SWITCH
154-2	P0605X154-2	ON/OFF SWITCH BRACKET
154-3	P0605X154-3	ON/OFF SWITCH BOX
154-4	P0605X154-4	ON/OFF SWICH CORD 14AWG X 3C
154-5	P0605X154-5	SAFETY PIN



Blade Guard Assembly Breakdown

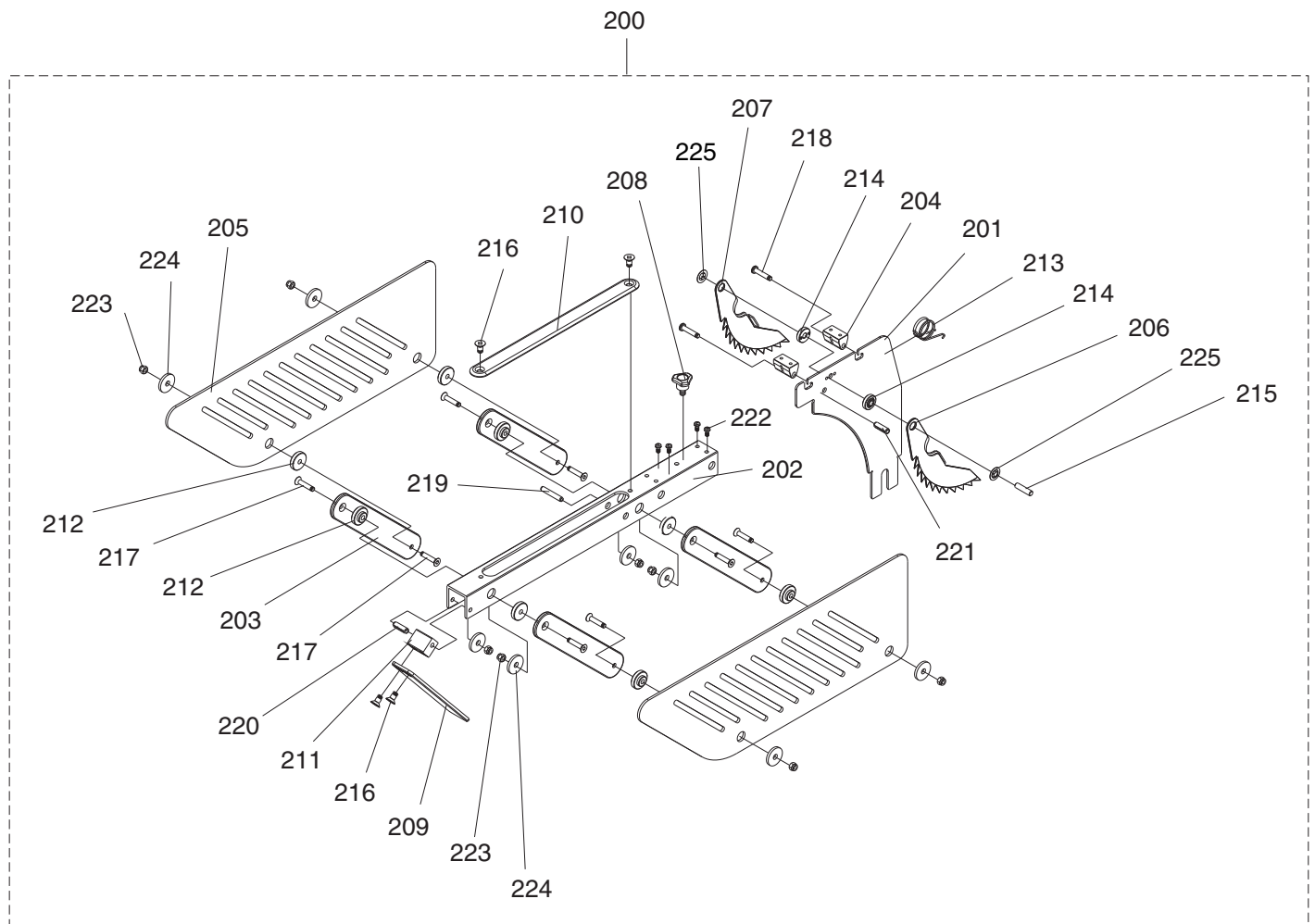

Blade Guard Parts List

REF	PART #	DESCRIPTION
200	P0605X200	BLADE GUARD ASSEMBLY
201	P0605X201	SPLITTER
202	P0605X202	SUPPORT
203	P0605X203	BLADE GUARD SWING BRACKET
204	P0605X204	BRACKET
205	P0605X205	BLADE GUARD COVER
206	P0605X206	RIGHT ANTI-BACK PAWL
207	P0605X207	LEFT ANTI-BACK PAWL
208	P0605X208	MITER GAUGE LOCK KNOB
209	P0605X209	FRONT COVER
210	P0605X210	UPPER COVER
211	P0605X211	BLOCK
212	P0605X212	SPACER

REF	PART #	DESCRIPTION
213	P0605X213	TORSION SPRING
214	P0605X214	RING 6MM
215	P0605X215	PIN 6 X 24
216	PFH43M	FLAT HD SCR M6-1 X 10
217	PFH54M	FLAT HD SCR M5-.8 X 20
218	PS22M	PHLP HD SCR M5-.8 X 25
219	PRP95M	ROLL PIN 8 X 55
220	PRP45M	ROLL PIN 5 X 32
221	PRP07M	ROLL PIN 6 X 20
222	PS07M	PHLP HD SCR M4-.7 X 8
223	PLN02M	LOCK NUT M5-.8
224	PW02M	FLAT WASHER 5MM
225	P0605X225	RING 6MM



Fence Assembly Breakdown

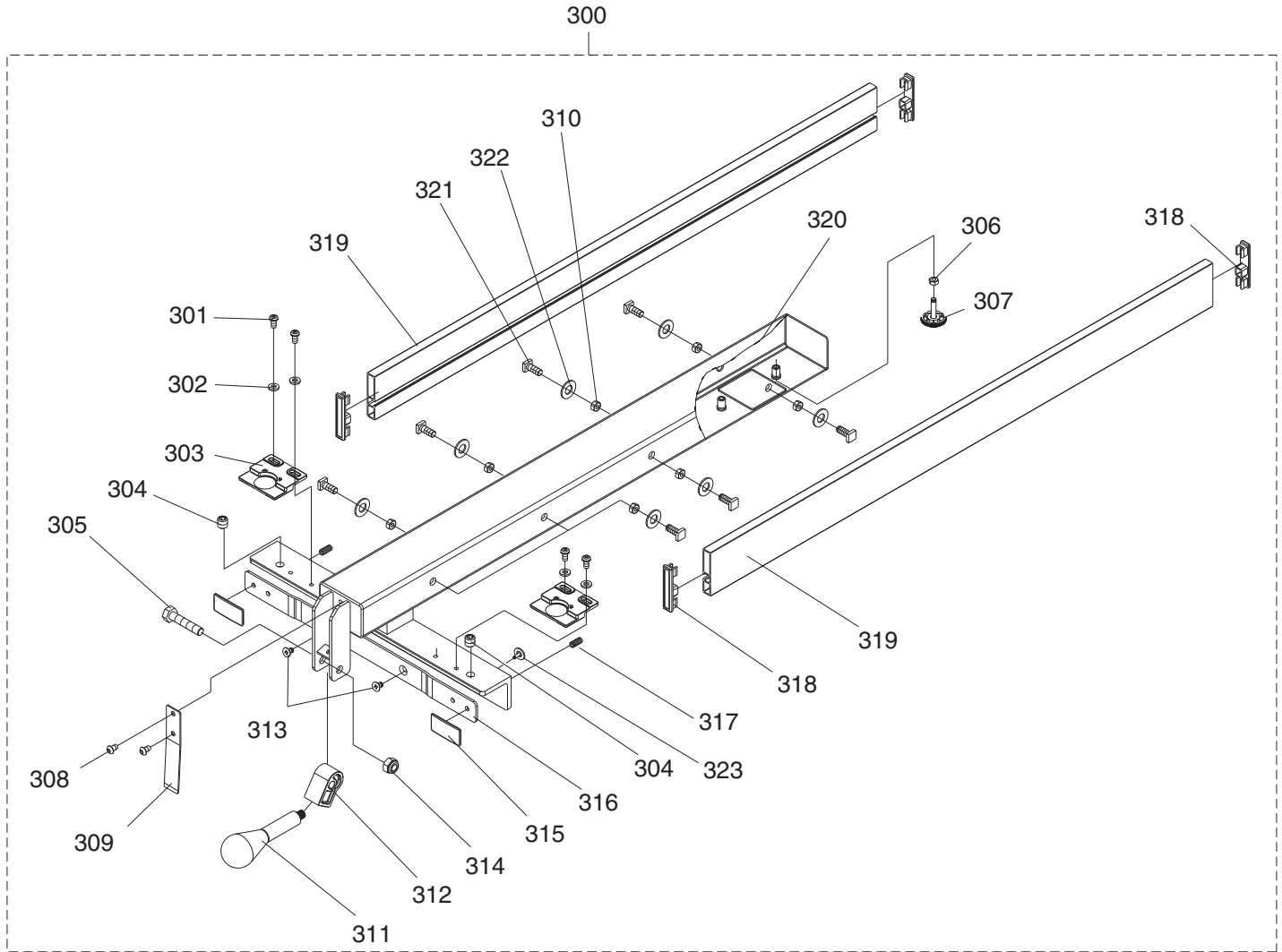

Fence Parts List

REF	PART #	DESCRIPTION
300	P0605X300	FENCE ASSEMBLY
301	PS68M	PHLP HD SCR M6-1 X 10
302	PW03M	FLAT WASHER 6MM
303	P0605X303	POINTER
304	P0605X304	PLASTIC SET SCREW
305	PB73M	HEX BOLT M10-1.5 X 50
306	PN01M	HEX NUT M6-1
307	P0605X307	REAR RAIL WHEEL
308	PSB26M	CAP SCREW M6-1 X 12
309	P0605X309	PLATE
310	PN03M	HEX NUT M8-1.25
311	P0605X311	FENCE HANDLE

REF	PART #	DESCRIPTION
312	P0605X312	CAM
313	PFH43M	FLAT HD SCR M6-1 X 10
314	PLN05M	LOCK NUT M10-1.5
315	P0605X315	PLATE
316	P0605X316	CLAMPING BRACKET
317	PSS20M	SET SCREW M8-1.25 X 8
318	P0605X318	PLATE CAP
319	P0605X319	FENCE PLATE
320	P0605X320	FENCE
321	P0605X321	T-BOLT M8-1.25 X 20
322	PW01M	FLAT WASHER 8MM
323	P0605X323	PLASTIC PAD



Miter Gauge Assembly Breakdown

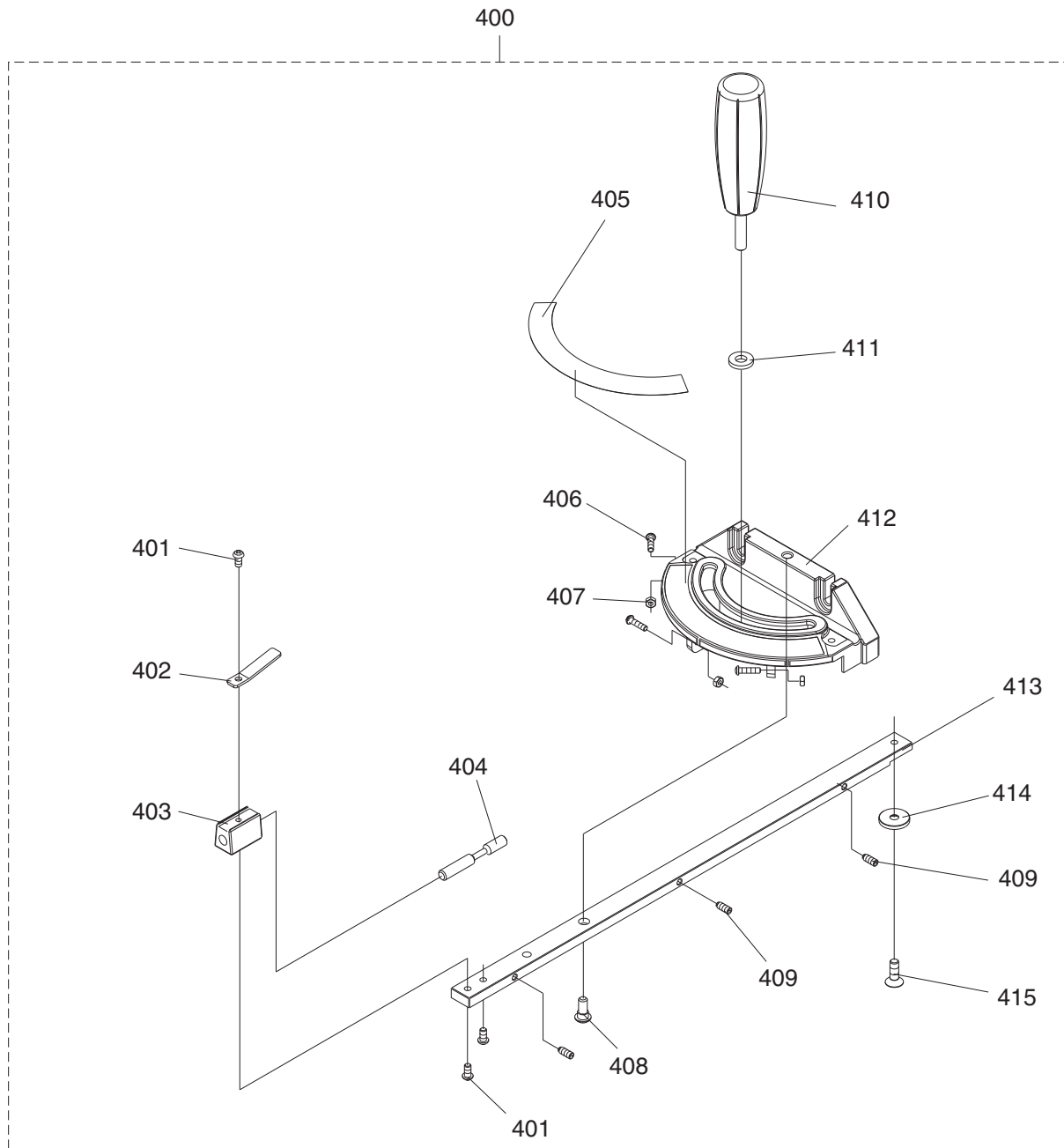

Miter Gauge Parts List

REF	PART #	DESCRIPTION
400	P0605X400	MITER GAUGE
401	PS06	PHLP HD SCR 10-24 X 3/8
402	P0605X402	POINTER
403	P0605X403	BLOCK
404	P0605X404	SHAFT
405	P0605X405	MITER GAUGE SCALE
406	P0605X406	PHLP HD SCR 5/32-32 X 5/8
407	P0605X407	HEX NUT 5/32-32

REF	PART #	DESCRIPTION
408	PS04	PHLP HD SCR 1/4-20 X 1/2
409	PSS53M	SET SCREW M5-.8 X 12
410	P0605X410	MITER GAUGE HANDLE
411	PW01M	FLAT WASHER 8MM
412	P0605X412	MITER GAUGE
413	P0605X413	PLATE
414	P0605X414	GUIDE PLATE
415	PFH9M	FLAT HD SCR M6-1 X 6



Extension Table Assembly Breakdown

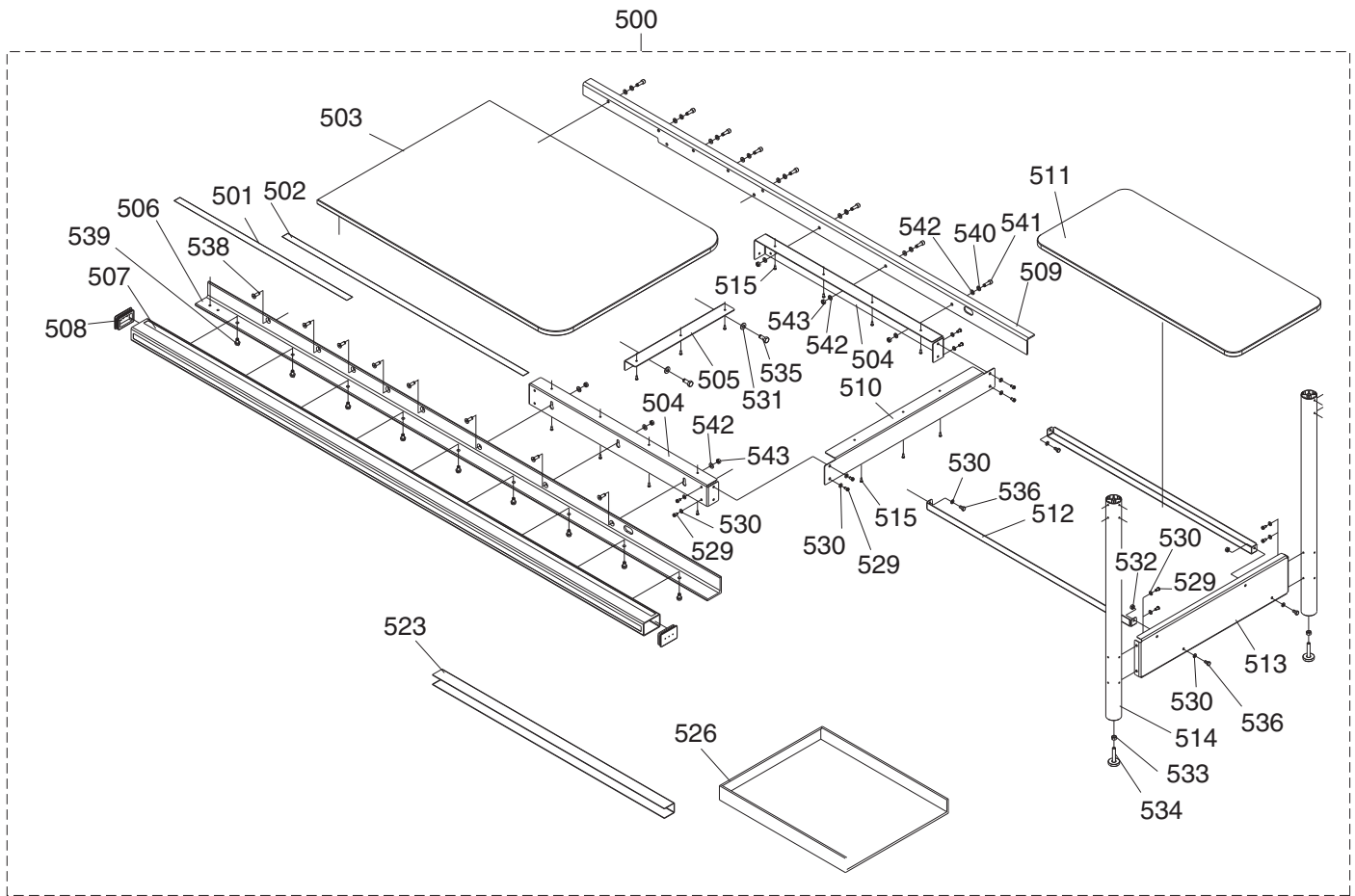

Extension Table Parts List

REF	PART #	DESCRIPTION
500	P0605X500	EXTENSION TABLE ASSEMBLY
501	P0605X501	LEFT SCALE
502	P0605X502	RIGHT SCALE
503	P0605X503	EXTENSION TABLE PLATE
504	P0605X504	EXTENSION TABLE SUPPORT
505	P0605X505	FRONT EXTENSION BRACKET
506	P0605X506	FRONT RAIL (91-3/8" LONG)
507	P0605X507	FENCE TUBE (91-3/8" LONG)
508	P0605X508	END CAP
509	P0605X509	REAR RAIL (79" LONG)
510	P0605X510	REAR EXTENSION BRACKET
511	P0605X511	LOWER SHELF
512	P0605X512	LOWER SHELF BRACKET
513	P0605X513	SHELF END PLATE
514	P0605X514	SUPPORT LEG
515	PHTEK6M	TAP SCREW M4 X 16

REF	PART #	DESCRIPTION
523	P0605X523	FRONT RAIL PLATE 52"
526	P0605X526	RIGHT EXTENSION PLATE
529	PS14M	PHLP HD SCR M6-1 X 12
530	PW03M	FLAT WASHER 6MM
531	PW04M	FLAT WASHER 10MM
532	PN01M	HEX NUT M6-1
533	PN08	HEX NUT 3/8-16
534	P0605X534	FOOT 3/8-16 X 2
535	PB32M	HEX BOLT M10-1.5 X 25
536	PS14M	PHLP HD SCR M6-1 X 12
538	PFH21M	FLAT HD SCR M8-1.25 X 25
539	PFB15M	FLANGE BOLT M8-1.25 X 12
540	PLW04M	LOCK WASHER 8MM
541	PSB31M	CAP SCREW M8-1.25 X 25
542	PW01M	FLAT WASHER 8MM
543	PN03M	HEX NUT M8-1.25



Outfeed Table Assembly Breakdown

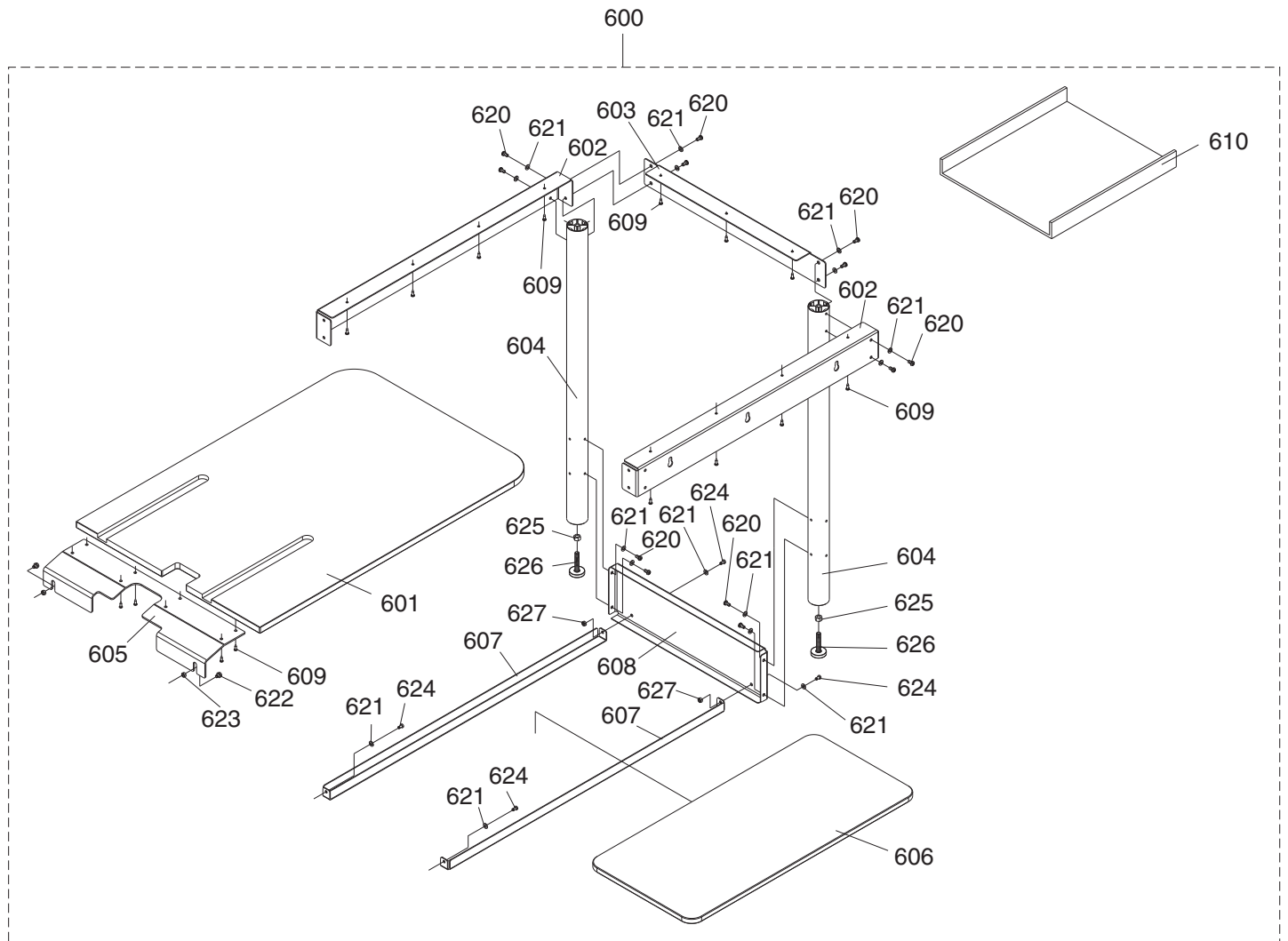

Outfeed Table Parts List

REF	PART #	DESCRIPTION
600	P0605X600	OUTFEED TABLE ASSEMBLY
601	P0605X601	OUTFEED TABLE PLATE
602	P0605X602	OUTFEED TABLE SUPPORT
603	P0605X603	REAR OUTFEED TABLE BRACKET
604	P0605X604	SUPPORT LEG
605	P0605X605	FRONT OUTFEED TABLE BRACKET
606	P0605X606	LOWER SHELF
607	P0605X607	LOWER SHELF BRACKET
608	P0605X608	SHELF END PLATE
609	PHTEK6M	TAP SCREW M4 X 16

REF	PART #	DESCRIPTION
610	P0605X610	REAR EXTENSION PLATE
620	PS14M	PHLP HD SCR M6-1 X 12
621	PW03M	FLAT WASHER 6MM
622	PFB16M	FLANGE BOLT M8-1.25 X 16
623	PN03M	HEX NUT M8-1.25
624	PS14M	PHLP HD SCR M6-1 X 12
625	PN08	HEX NUT 3/8-16
626	P0605X626	FOOT 3/8-16 X 2
627	PN01M	HEX NUT M6-1



Warning Label Parts List

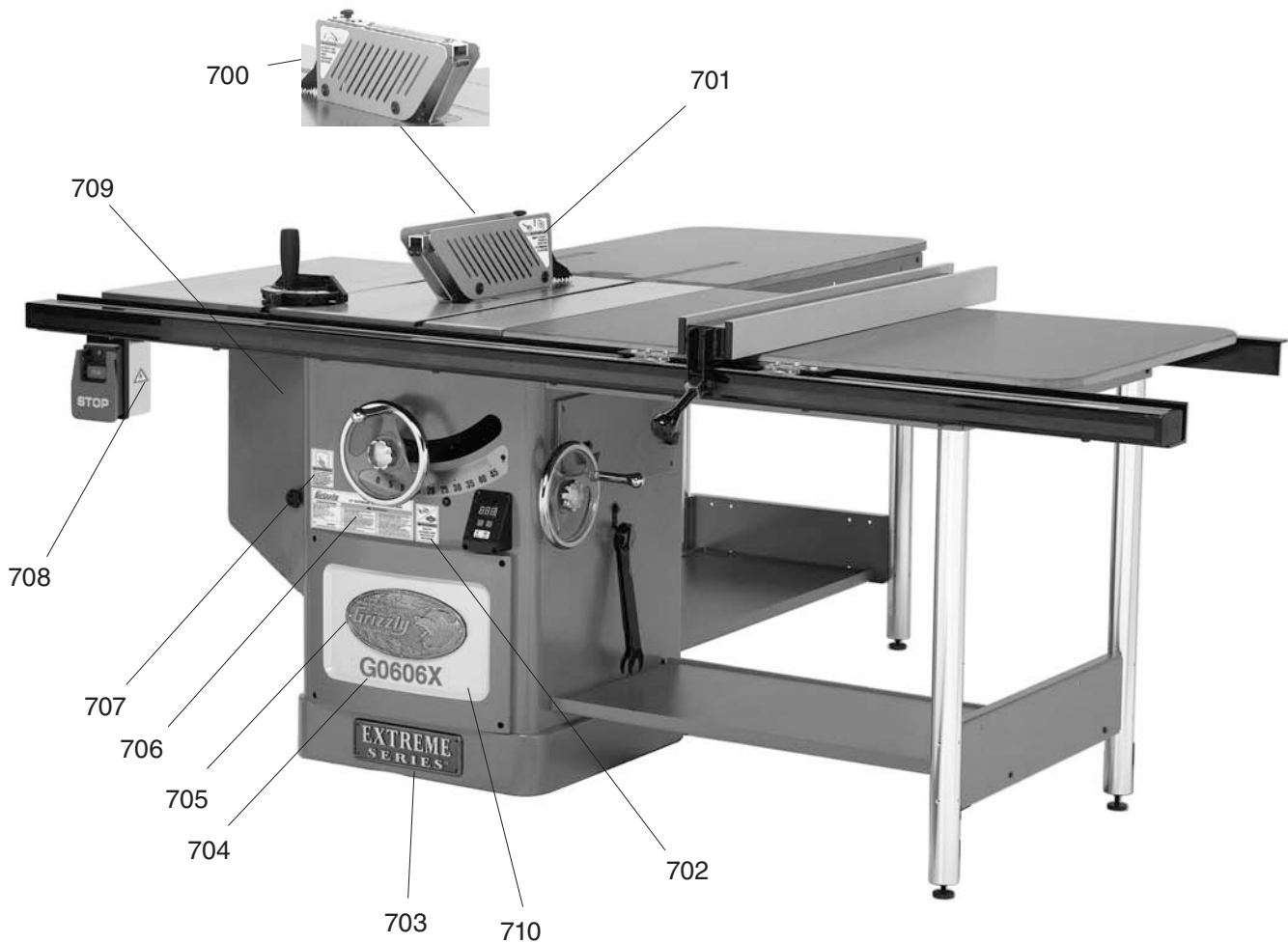

REF	PART #	DESCRIPTION
700	P0605X700	GUARD AND ANTI-KICK BACK LABEL
701	P0605X701	DISCONNECT POWER-BLADES LABEL
702	P0605X702	SAFETY GLASSES-HEARING LABEL
703	H7942	EXTREME SERIES PLATE
704	P0605X704	MODEL NUMBER LABEL G0605X
704	P0606X704	MODEL NUMBER LABEL G0606X
705	G8589	GRIZZLY NAMEPLATE-LARGE

REF	PART #	DESCRIPTION
706	P0605X706	MACHINE ID LABEL G0605X
706	P0606X706	MACHINE ID LABEL G0606X
707	PLABEL-12A	READ MANUAL-VERTICAL NS 7/05
708	PLABEL-14	ELECTRICITY LABEL
709	PPAINT-1	GRIZZLY GREEN PAINT
710	PPAINT-11	PUNITY TOUCH-UP PAINT

WARNING

Safety labels warn about machine hazards and ways to prevent injury. The owner of this machine **MUST** maintain the original location and readability of the labels on the machine. If any label is removed or becomes unreadable, **REPLACE** that label before using the machine again. Contact Grizzly at (800) 523-4777 or www.grizzly.com to order new labels.

