

# INSTRUCTIONS FOR C1392, C1652, C1653, C1654 REVERSIBLE STILE AND RAIL SETS

## ⚠️ WARNING

- Failure to follow these guidelines will result in serious personal injury.
- ALWAYS WEAR ANSI APPROVED EYE AND EAR PROTECTION WHEN USING THIS BIT.
- The use of a router table is strongly recommended.
- Never feed lumber with the rotation of the bit.
- Follow the safety guidelines set forth by the manufacturer of the router and router table.
- Always make sure the router bit components are tight, the bit is secured in the router, AND the wood is free of defects or nails.

# Grizzly

Industrial, Inc. ®

## ⚠️ CAUTION

These router bits have sharp edges. Use care while removing the waxy protective coating. Never turn on the router with the protective coating still on the bit.

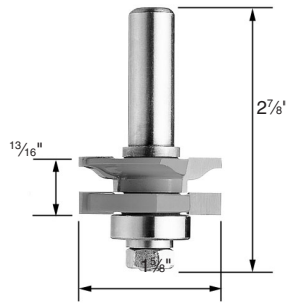

The stile and rail assembly allows the stile and rail parts of a door frame to be easily machined with the same router bit by reversing the components. The stile and rail bit comes complete with a ball bearing guide and shim set. This reversible stile and rail set has been designed to produce raised panel cabinet door frames using 3/4" material. It cuts a 1/4" x 3/8" tongue and groove in the stile and rail.

It is advisable to first use the reversible stile and rail bit on test material to familiarize yourself with its use. When cutting rail stock to length, it is not necessary to add extra length to compensate for the rail tenons. The metal shim set included with your bit is used to adjust the tightness of the joint if necessary. For safety and best results, we recommend the use of a table mounted router with adjustable fence(s) and miter gauge.

### Step 1: Cutting Rail Ends

Assemble the router bit assembly as shown in Figure A. Make sure the fully exposed carbide appears on the left of the bit as shown below. Failure to do so will effect performance and/or can result in serious injury. Do not use shims at this time. When cutting rail ends, use a miter gauge or jig.

Note: The workpiece must always be fed against the cutter rotation and the full depth of profile should be made in one pass to ensure a precise cut. Before turning the router on, set the rail on the table finished face up. Slide the miter gauge up to in and move both up to the router bit. Slide the lumber along the miter gauge face until it contacts the bearing. Pull miter gauge and stock back from the router bit before starting router. We recommend using a back-up piece of wood against the rail to prevent end grain tear-out. Rotate the board end for end, maintaining the face-up position and cut the other end. A clamping device may be necessary to keep the workpiece secured against the miter gauge.

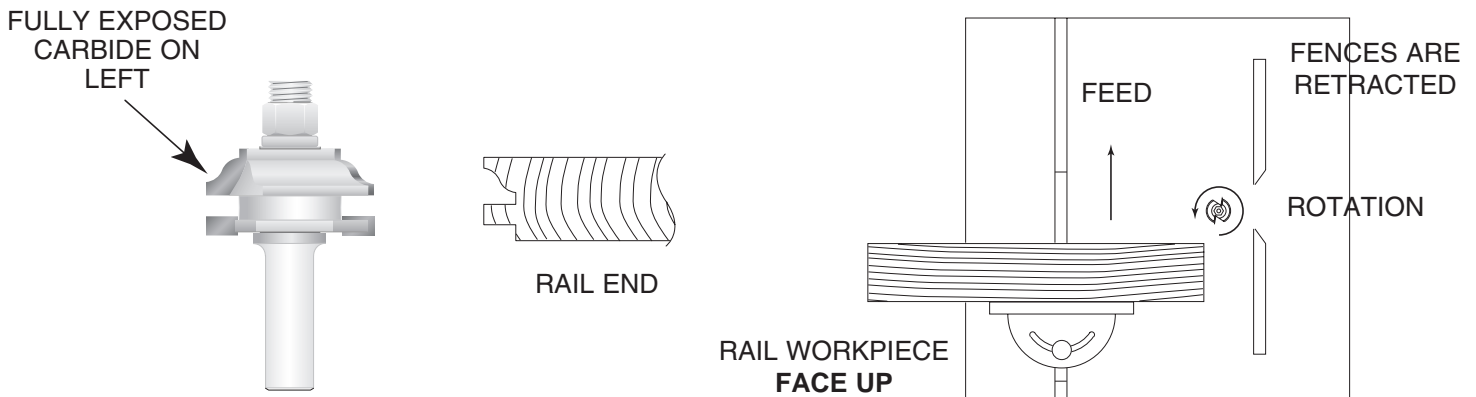

Figure A.

## Step 2: Cutting Stile and Rail Edges

To shape the stile and rail edges, disconnect the router from the power source and reposition the cutters and bearing as shown in **Figure B**. Do not use shims at this time. To remove the nut on the end of the bit, leave the bit chucked in the router's collet and use the spindle lock on the router or the wrench for the collet to stay the spindle. Line up the router table fence(s) with the guide bearing on the router bit. Check it with good quality straight edge.

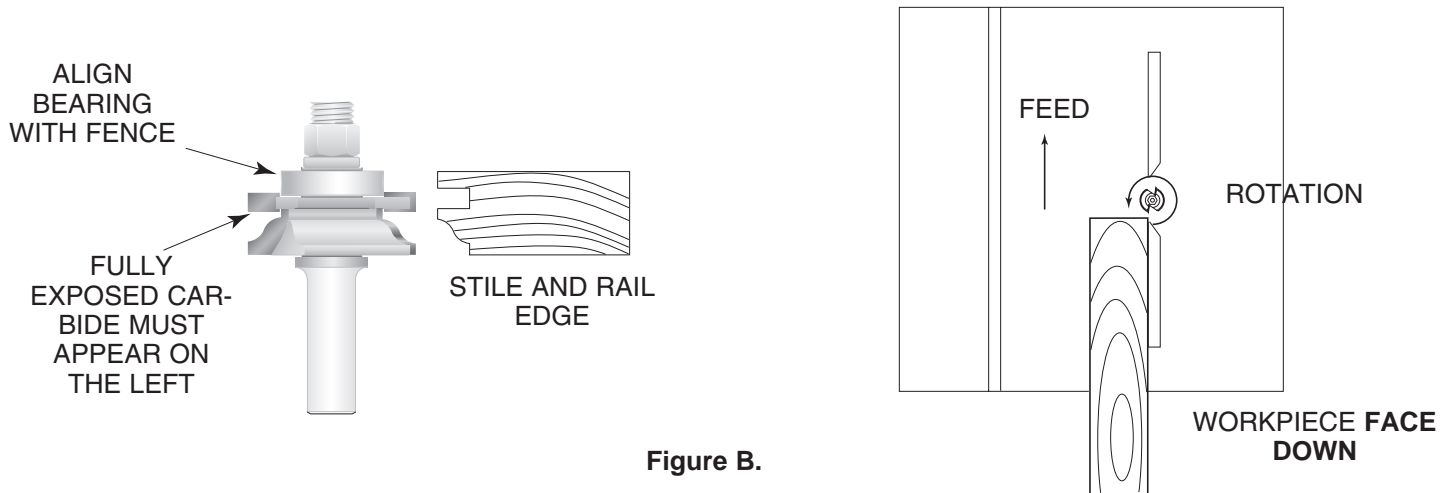

Figure B.

Re-check the height and position of the cutters before making the edge profile cut to ensure that the face of both pieces being joined will align properly.

The position of the profile on the workpiece and variance in material thickness will also affect alignment. It is therefore very important that the test material is milled to the same thickness as your finished pieces to make an accurate setup.

## ADJUSTMENTS

Join the two pieces together and judge the quality of the joint. If the tongue fits too loosely, go back to **Step 1** and place a metal shim between the guide bearing and the  $\frac{1}{4}$ " straight cutter and re-test. Repeat this process until desired fit is achieved. If the two pieces are not flush, re-check height adjustment. **See Figure C.**

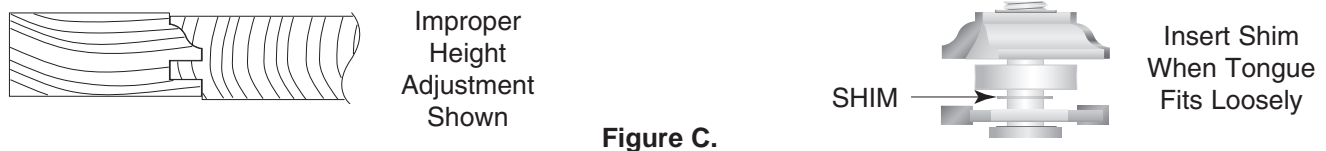

Figure C.

## OTHER CONSIDERATIONS

If this is your first time performing panel door construction, start simple by making a square door. Doors having more intricate designs such as arched, tombstone or curved panels should only be done when you are confident of your ability. If your project requires curved pieces then freehand shaping will be necessary. Remove the fence(s) and always incorporate the use of a starting pin or block to support the workpiece as it is initially fed into the cutter. Always use some type of jig or hold-down device to make the operation safer and to avoid having your hand in close proximity to the spinning cutter.

We stress the importance of working with good quality material and insuring that all pieces are machined the same and that all ends and edges are cut square. Follow all recommended safety procedures and always test your setup using sample pieces.

**Figure D** shows the typical stile and rail, panel door components. For router bits to make panels, please see our latest catalog.

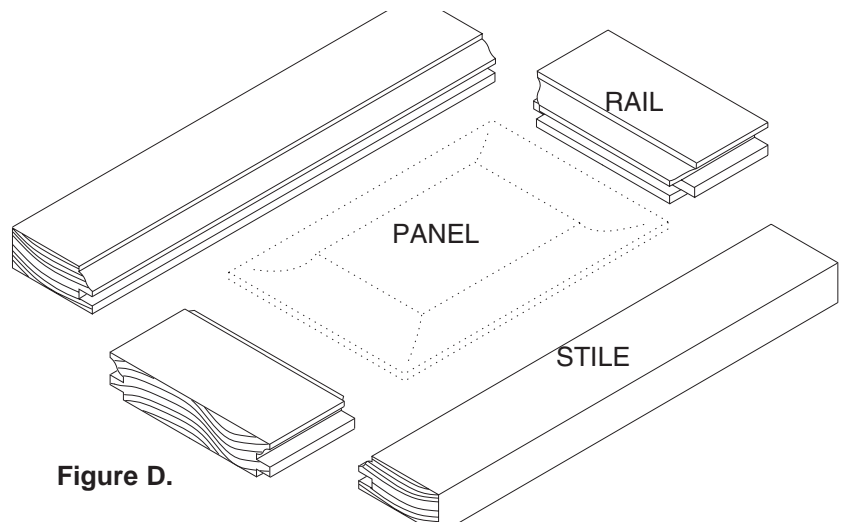

Figure D.