



# INSTRUCTIONS FOR C1393-96, C1651 STILE AND RAIL SETS

## INTRODUCTION

Deluxe carbide-tipped Stile and Rail bits in a number of classic and contemporary styles, offer excellent performance for the serious woodworker or cabinetmaker working with stile and rail materials, ranging from  $\frac{3}{4}$ " to  $\frac{7}{8}$ " widths. Two-piece router bit sets enable you to increase productivity by keeping two routers pre-adjusted.

### **! WARNING**

- Failure to follow these guidelines will result in serious personal injury.
- **ALWAYS WEAR ANSI APPROVED EYE AND EAR PROTECTION** when using this bit.
- Always use a router table when using these bits, **NEVER** attempt to use a hand-held router.
- Never feed lumber with the rotation of the cutter.
- Follow the safety guidelines set forth by the manufacturer of the router and router table.

Although these bits can be used hand-held with proper jigs and fixtures, we recommend using them in a router table, such as the Rebel® Router Table by Woodstock International.

#### To get the most from these carbide-tipped stile and rail bits:

1. For maximum efficiency, secure each bit in a router and plan all of your cuts to minimize bit changes (or keep each bit in a separate router).
2. Adjust the router and bit in your router table, so the bit offers a full profile in addition to about  $\frac{1}{8}$ " of indentation on the front edge of the material. You will be milling your material back side up, so the indentation will be at table level. (See the illustration to the right.)

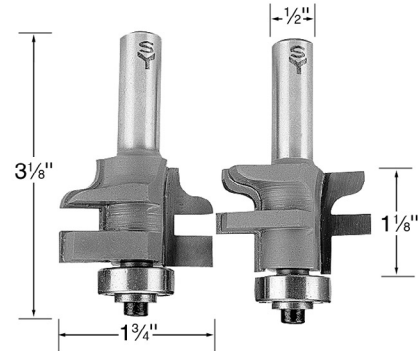
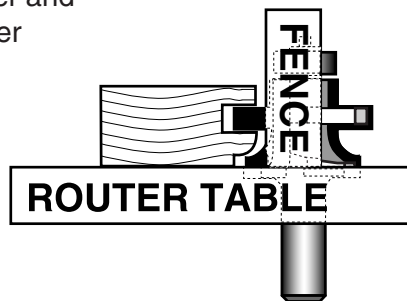

Stile and Rail Set

### **! CAUTION**

These router bits have sharp edges. Use care while removing the waxy protective coating. Never turn on the router with the protective coating still on the bit.

### **! WARNING**

- Unplug router before installing or adjusting cutter.
  - Keep all guards and anti-kickback devices in place.
  - Double check bit to insure it is tight and secure in router.
  - Always inspect lumber and other wood materials for cracks, knots, or other imperfections that could cause lumber to kick or shatter while milling.
3. Once the bit is properly adjusted and tightened in place, use a length of surplus material that is the same thickness as your workpiece for a test cut. If you are satisfied with your results, continue with your project material engagement to ensure an equal depth of cut.

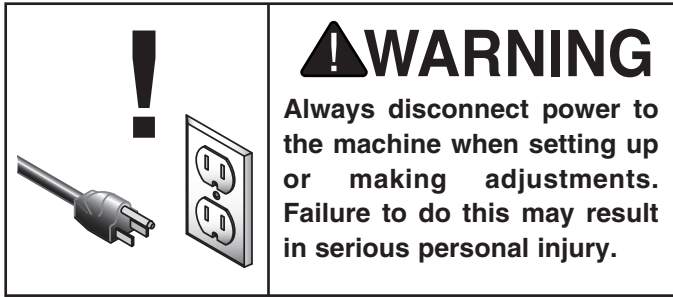

The process for completing your rail end cuts is roughly the same as those for your stile and rail cuts. The main concern is ensuring that the amount of reveal at the front edge of your rail matches the cuts made in your stiles.

**To complete your end rail cuts:**

1. Adjust your router and bit, as described earlier, and make a test cut with the surplus material.

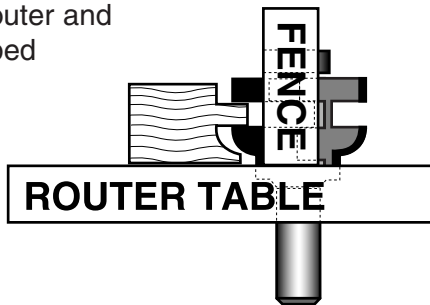

2. Join the test cut with your previous cuts and check the joint to determine flushness.
3. Re-adjust and re-test until you are satisfied with your results.
4. When satisfied with the results tighten the router and cut your project material.

A ball bearing is supplied with these router bits which allow the use of templates for curved work as seen to the right.

**Using a template:**

1. The template should be the same size as the expected finished panel.

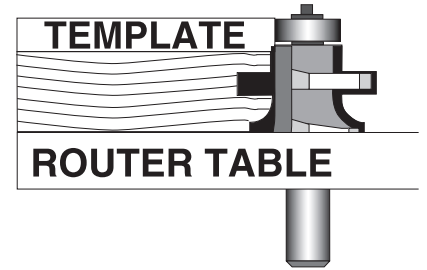

2. The curved portion of the workpiece should be rough cut so that no more than 1/8" protrudes beyond the template.
3. The fence and miter must be removed when using a template. A starting pin or block must be installed as shown in Figure 2.

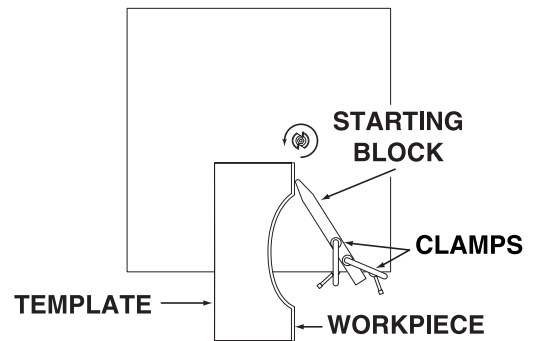

**Figure 2.** Start block for template cutting.