

# INSTRUCTIONS FOR MODELS C1407, C1408, C1409, C1410 AND C1411 3" PANEL ROUTER BITS WITH UNDERCUTTER

# Grizzly

Industrial, Inc.®

## ⚠ WARNING

- Failure to follow these guidelines will result in serious personal injury.
- ALWAYS WEAR ANSI APPROVED EYE AND EAR PROTECTION WHEN USING THIS router bit.
- These router bits should only be used on a router table, never in a handheld router.
- Never feed lumber with the rotation of the bit.
- Follow the safety guidelines set forth by the manufacturer of the router.

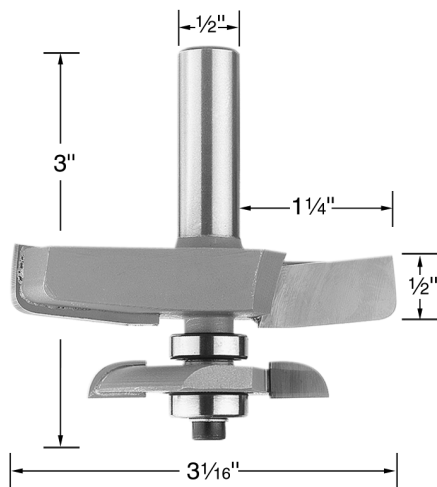

## ⚠ CAUTION

These router bits have sharp edges. Use care while removing the waxy protective coating. Never turn on the router with the protective coating still on the bit.

These panel bits can be used with  $\frac{5}{8}$ " -  $\frac{3}{4}$ " stock. The undercutter enables the cutting of the panel section of the door in one single pass. The cutter is designed to produce a  $\frac{1}{4}$ " thick tongue which can float in a  $\frac{5}{16}$ " wide by  $\frac{3}{8}$ " deep groove in the door frame. This provides an approximate 1" to  $1\frac{1}{8}$ " reveal for the door panel edge. If the door frame is being made with a standard stile and rail bit, many of these are designed with a  $\frac{1}{4}$ " wide groove.

## ⚠ WARNING

- Unplug router before installing or adjusting cutter.
- Keep all guards and anti-kick-back devices in place.
- Double check bit to insure screw is tight and bit is tightly secured in spindle.
- Always inspect lumber and other wood materials for cracks, knots, or other imperfections that could cause lumber to kick or shatter while milling.

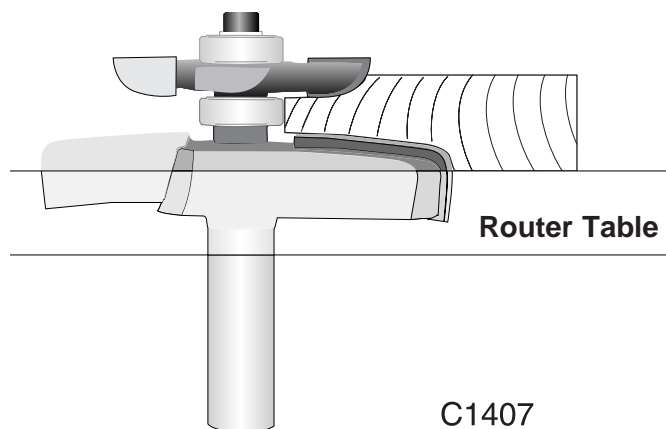

The panel can be produced so that it finishes flush with the stile and rail assembly or so that the panel is "raised". This is accomplished by raising or lowering the bit so that the tongue of the finished panel moves up or down. In the illustration above, note that the face of the panel is in the down position. If the bit is moved down, the panel will mount proud of the stile and rail. If moved up, the panel will finish closer to flush. Use scrap lumber to make a cuts until you have produced your desired height.

Shown below are other profiles that can be produced using router bits from Grizzly Industrial, Inc.

# Profile Guide

