

# INSTRUCTIONS FOR C1689, C1690, C1691, C1692 ONE PIECE STILE AND RAIL SET

# Grizzly

Industrial, Inc.®

## ⚠ WARNING

- Failure to follow these guidelines will result in serious personal injury.
- ALWAYS WEAR ANSI APPROVED EYE AND EAR PROTECTION WHEN USING THIS BIT.
- The use of a router table is strongly recommended.
- Never feed lumber with the rotation of the bit.
- Follow the safety guidelines set forth by the manufacturer of the router and router table.

## ⚠ CAUTION

These router bits have sharp edges. Use care while removing the waxy protective coating. Never turn on the router with the protective coating still on the bit.

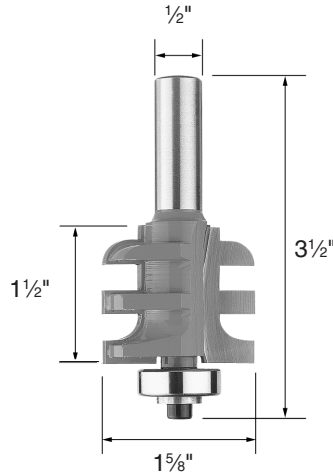

Designed to provide a convenient method for cutting both stiles and rails with just one bit, the Model C1689-92 series bits with guide bearings offer an easy and inexpensive alternative to deluxe two-piece stile and rail sets. For best results, we recommend using these bit with router tables and a router rated at 1-horsepower or larger. This bit is designed for use with 3/4" thick material.

**Note:** These instructions and drawings are intended for explanation and clarification purposes only as they relate to this particular router bit. Apply all safety rules and measures pertaining to router operations and your specific operation. Refer to the owner's manual supplied with your router and router table for specific warnings and instructions before proceeding with equipment operations.

### Step 1: Cutting Stile and Rail Edges

Make sure the router is disconnected from the power source. Attach the router and router bit to your router table and adjust the height of the bit until the top of the cutting surface matches the top of your 3/4" stile. Adjust the fence until it is flush with the groove depth. (The guide bearing is not used when the bit is in a router table. The bearing can be used when you are cutting non-linear shapes such as a curved arch door rail, however a template made from at least 3/4" thick material must be made and attached to the workpiece.) The workpiece must always be fed against the cutter rotation and the full depth of profile should be made in one pass to ensure a precise cut. Before plugging in the router, set the rail or stile on the table finished face up. Lay the edge to be cut firmly against the fence. A hold-down device such as a featherboard should be used to keep the workpiece secured against the fence. Using a spare piece of material, make a test cut to ensure that the complete profile is being cut. Adjust, if necessary, and re-test.

ADJUST SO THESE  
TWO SURFACES ARE  
EVEN

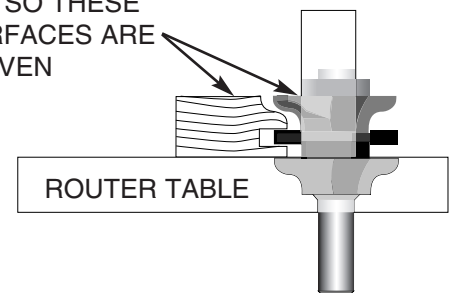

Run all of the stiles and rails for the project through the cutter before adjusting it to do the rail ends.

## ⚠ WARNING

- Unplug router before installing or adjusting cutter.
- Keep all guards and anti-kickback devices in place.
- Double check bit to insure screw is tight and bit is tightly secured in router.
- Always inspect lumber and other wood materials for cracks, knots, or other imperfections that could cause lumber to kick or shatter while milling.

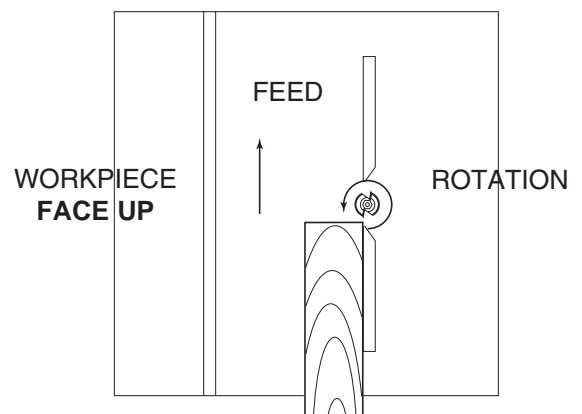

## Step 2: Cutting Rail Ends

Raise the router bit in the table until the top of the workpiece material is flush with the lower section of the cutter as shown in **Figure B**. The miter should be "faced" with a piece of stock so that the workpiece will be supported closely to the router bit. Make sure to secure this stock with screws. Run a test piece which is the exact same thickness as your actual stile and rail stock. Note: when cutting the rail ends, the workpiece should be face down on the router table. Test fit the rail and the stile to see how the joint looks. If the pieces do not fit together tightly, or if the front and back surfaces do not fit flush, it may be necessary to readjust. Make very small movements in the height of the router bit and test cut again.

When the fit is properly adjusted, position the rail against a backup piece with the miter gauge positioned as shown in **Figure A**. The workpiece must always be fed against the cutter rotation and the full depth of profile should be made in one pass to ensure a precise cut. Rotate the board end for end, maintaining the face-down position and cut the other end. A clamping device may be necessary to keep the workpiece secured against the miter gauge.

The position of the profile on the workpiece and variance in material thickness will also affect alignment. It is therefore very important that test material is milled to the same thickness as the finished material to ensure an accurate setup.

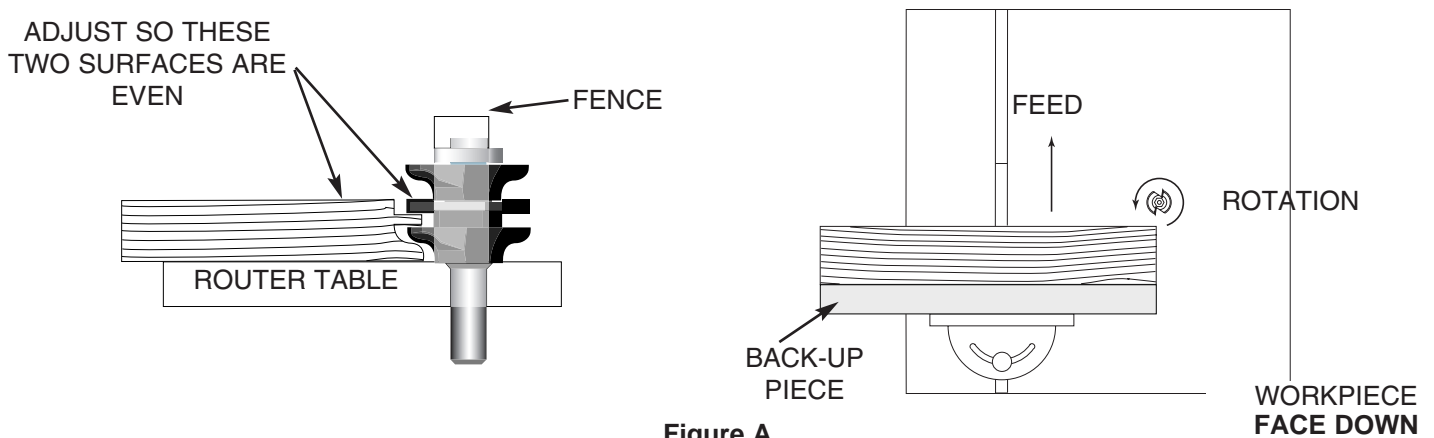

## OTHER CONSIDERATIONS

**Figure B** shows the typical stile and rail, panel door components. For router bits to make raised panels, please see our latest catalog. Doors having more intricate designs such as arched, tombstone or curved panels should only be done when you are confident of your ability. If your project requires curved pieces then freehand routing using the bearing and a template will be necessary. Remember that it is important to work with good quality material and to insure that all pieces are machined the same and that all ends and edges are cut square. Follow all recommended safety procedures and always test the setup using sample pieces.

