

Grizzly *Industrial, Inc.*®

MODEL G0621 WOOD/METAL BANDSAW OWNER'S MANUAL



COPYRIGHT © FEBRUARY, 2007 BY GRIZZLY INDUSTRIAL, INC. REVISED MAY, 2009 (TR)
**WARNING: NO PORTION OF THIS MANUAL MAY BE REPRODUCED IN ANY SHAPE
OR FORM WITHOUT THE WRITTEN APPROVAL OF GRIZZLY INDUSTRIAL, INC.**
(FOR MACHINES MFG. SINCE 10/06) #TR8986 PRINTED IN TAIWAN

 **WARNING!**

This manual provides critical safety instructions on the proper setup, operation, maintenance and service of this machine/equipment.

Failure to read, understand and follow the instructions given in this manual may result in serious personal injury, including amputation, electrocution or death.

The owner of this machine/equipment is solely responsible for its safe use. This responsibility includes but is not limited to proper installation in a safe environment, personnel training and usage authorization, proper inspection and maintenance, manual availability and comprehension, application of safety devices, blade/cutter integrity, and the usage of personal protective equipment.

The manufacturer will not be held liable for injury or property damage from negligence, improper training, machine modifications or misuse.

 **WARNING!**

Some dust created by power sanding, sawing, grinding, drilling, and other construction activities contains chemicals known to the State of California to cause cancer, birth defects or other reproductive harm. Some examples of these chemicals are:

- **Lead from lead-based paints.**
- **Crystalline silica from bricks, cement and other masonry products.**
- **Arsenic and chromium from chemically-treated lumber.**

Your risk from these exposures varies, depending on how often you do this type of work. To reduce your exposure to these chemicals: Work in a well ventilated area, and work with approved safety equipment, such as those dust masks that are specially designed to filter out microscopic particles.

Table of Contents

INTRODUCTION	2	SECTION 5: ACCESSORIES	36
Manual Accuracy	2	SECTION 6: MAINTENANCE	37
Contact Info.....	2	Schedule	37
Machine Data Sheet	3	Cleaning.....	37
Identification.....	5	Lubricating	37
SECTION 1: SAFETY	6	Redressing Rubber Tires.....	37
Safety Instructions for Machinery	6	SECTION 7: SERVICE	38
Additional Safety Instructions for Bandsaws .	8	Troubleshooting	38
SECTION 2: CIRCUIT REQUIREMENTS	9	Servicing V-Belts.....	40
220V Single-Phase Operation	9	Shimming Table	42
SECTION 3: SETUP	10	Blade Lead.....	42
Setup Safety	10	Wheel Alignment.....	43
Items Needed for Setup.....	10	SECTION 8: WIRING	45
Unpacking	10	Wiring Safety Instructions	45
Inventory	11	Electrical Component Wiring	46
Hardware Recognition Chart	12	Wiring Diagram	47
Cleanup.....	13	SECTION 9: PARTS	48
Site Considerations.....	14	Main Parts Breakdown.....	48
Assembly	15	Main Parts List	49
Dust Collection.....	18	Table/Blade Guides Parts Breakdown.....	50
Blade Tracking.....	18	Secondary Parts Breakdown	51
Test Run	19	Stand Parts Breakdown	52
Tensioning Blade	20	Fence Parts Breakdown	53
Adjusting Support Bearings	20	Safety Labels Parts Breakdown.....	54
Adjusting Blade Guides	22	WARRANTY AND RETURNS	57
Adjusting Positive Stop	23		
Setting Table.....	23		
Tilt Scale to 0°	23		
Aligning Table	24		
Aligning Fence	24		
SECTION 4: OPERATIONS	25		
Operation Safety	25		
Basic Controls.....	25		
Workpiece Inspection (Wood).....	26		
Overview	26		
Table Tilt	27		
Guide Post	27		
Ripping.....	28		
Crosscutting.....	28		
Resawing	29		
Cutting Curves	30		
Stacked Cuts.....	30		
Blade Selection (Wood Cutting).....	31		
Blade Selection (Metal Cutting)	33		
Blade Changes	34		
Scale Calibration.....	35		

INTRODUCTION

Manual Accuracy

We are proud to offer this manual with your new machine! We've made every effort to be exact with the instructions, specifications, drawings, and photographs of the machine we used when writing this manual. However, sometimes errors do happen and we apologize for them.

Also, owing to our policy of continuous improvement, **your machine may not exactly match the manual**. If you find this to be the case, and the difference between the manual and machine leaves you in doubt, check our website for the latest manual update or call technical support for help.

Before calling, find the manufacture date of your machine by looking at the date stamped into the machine ID label (see below). This will help us determine if the manual version you received matches the manufacture date of your machine.

		MODEL GXXXX MACHINE NAME	
SPECIFICATIONS		▲ WARNING!	
Motor:		Manufacture Date of Your Machine ing this machine: operation. s and respirator. sted/setup and suit before starting.	
Specification:			
Specification:			
Specification:			
Weight:			
<input type="text"/>	Date	<ol style="list-style-type: none">4. Make sure the motor has stopped and disconnect power before adjustments, maintenance, or service.5. DO NOT expose to rain or dampness.6. DO NOT modify this machine in any way.7. DO NOT remove safety guards.8. Never leave machine running unattended.9. DO NOT operate under the influence of drugs or alcohol.10. Maintain machine carefully to prevent accidents.	
<input type="text"/>	Serial Number		
Manufactured for Grizzly in Taiwan			

For your convenience, we post all available manuals and manual updates for free on our website at www.grizzly.com. Any updates to your model of machine will be reflected in these documents as soon as they are complete.

Contact Info

We stand behind our machines. If you have any service questions, parts requests or general questions about the machine, please call or write us at the location listed below.

Grizzly Industrial, Inc.
1203 Lycoming Mall Circle
Muncy, PA 17756
Phone: (570) 546-9663
Fax: (800) 438-5901
E-Mail: techsupport@grizzly.com

If you have any comments regarding this manual, please write to us at the address below:

Grizzly Industrial, Inc.
c/o Technical Documentation Manager
P.O. Box 2069
Bellingham, WA 98227-2069
Email: manuals@grizzly.com





MACHINE DATA SHEET

Customer Service #: (570) 546-9663 • To Order Call: (800) 523-4777 • Fax #: (800) 438-5901

MODEL G0621 WOOD/METAL CUTTING BANDSAW

Product Dimensions:

Weight	236 lbs.
Length/Width/Height	30" x 30" x 72½"
Footprint (Length/Width)	27" x 15"

Shipping Dimensions:

Type	Cardboard
Content.....	Machine
Weight.....	246 lbs.
Length/Width/Height.....	56" x 27" x 16"

Electrical:

Required Power Source.....	220V, Single-Phase
Switch.....	ON/OFF Push Button w/Large STOP Paddle
Cord Length	6 ft.
Cord Gauge	16 gauge
Recommended Circuit Size	15 amp
Plug Included	No
Recommended Plug	6-15

Motor:

Horsepower.....	1.25 HP
Voltage.....	220V
Phase.....	3-Phase
Cycle	60 Hz
Type	Induction
Amps.....	4.8
Speed.....	1725 RPM
Bearings.....	Sealed and Lubricated
Power Transfer	Belt Drive

Main Specifications:

Throat Capacity Left-of-Blade	13½"
Maximum Resaw Height.....	10"
Blade Speeds.....	Variable 150-3000 FPM
Blade Length.....	108"
Blade Width Range	1/8"-1"
Table Size (Length, Width, Thickness).....	16" x 20" x 1¾"
Table Tilt	-5° to 45°
Table Height from Floor	38½"
Wheel Diameter	14"
Number of Dust Ports	1
Dust Port Size.....	2.5"
Fence Locking Location.....	Front



Construction Materials:

Wheels Fully Balanced Aluminum
Wheel Covers Steel
Table Precision Ground Cast Iron
Fence Aluminum
Base Steel
Body Steel
Paint Powder Coated

Other Specifications:

Compatible Shop Fox Mobile Base Available from Grizzly G7315
Country Of Origin Taiwan
Sound Rating 74 dB
Warranty 1 Year
Serial Number Location ID Label on Center of Upper Wheel Cover
Approximate Assembly & Setup Time 1.5 Hours



Identification

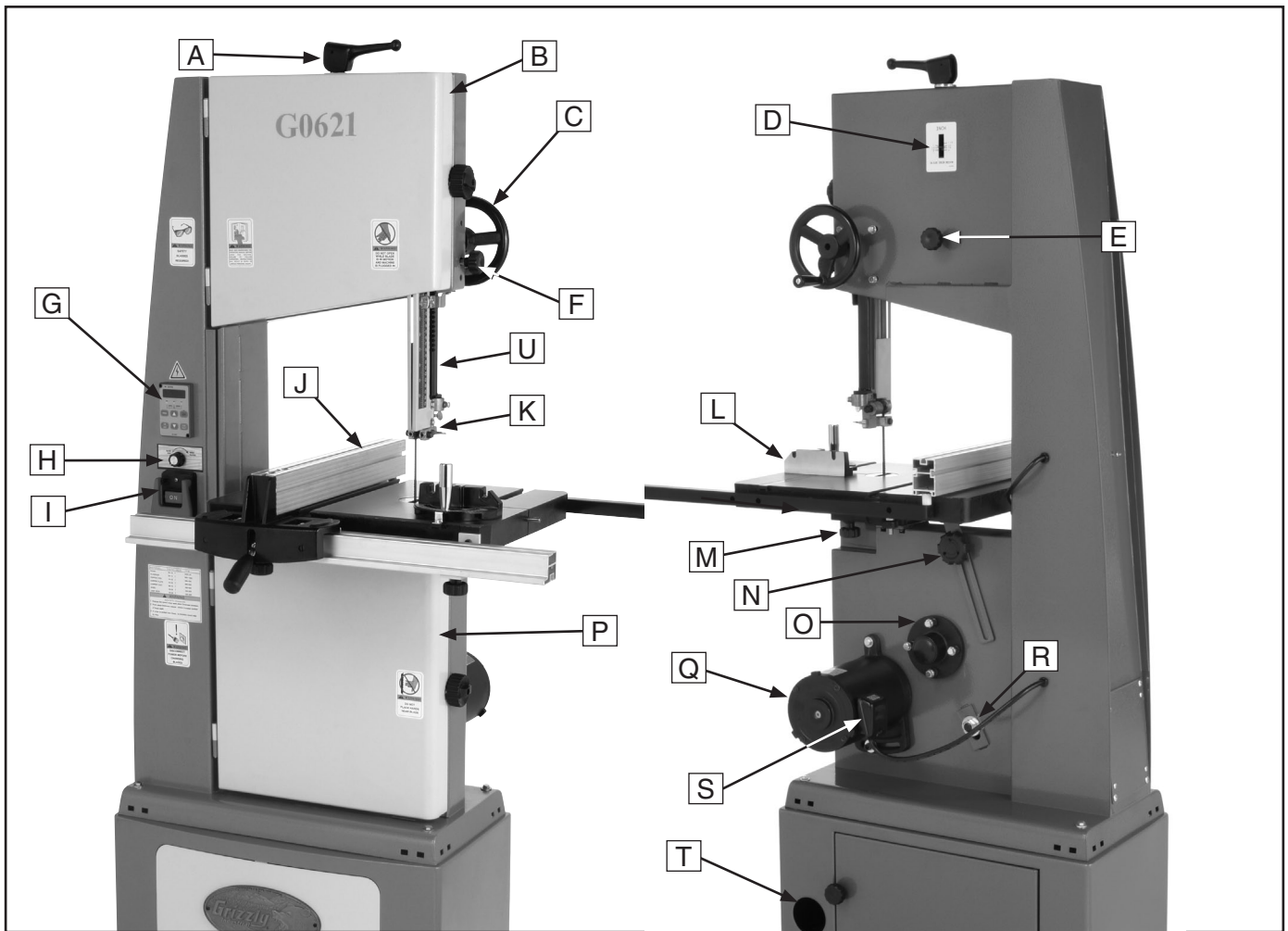

- | | |
|---|---|
| A. Blade Tension Handle | L. Miter Gauge |
| B. Upper Wheel Cover | M. Table Tilt Lock Knob (1 of 2) |
| C. Blade Guide Elevation Handwheel | N. Rear Table Support Lock Knob |
| D. Blade Tension Scale | O. Lower Wheel Adjustment Hub |
| E. Blade Tracking Knob | P. Lower Wheel Cover |
| F. Blade Guide Elevation Lock Knob | Q. Motor |
| G. Motor Switch | R. Belt Tension Lock Nut |
| H. Speed Dial | S. Motor Junction Box |
| I. Power Switch | T. Dust Hose Access Hole |
| J. Fence | U. Blade Guard |
| K. Upper Blade Guide Assembly | |



SECTION 1: SAFETY

WARNING

For Your Own Safety, Read Instruction Manual Before Operating this Machine

The purpose of safety symbols is to attract your attention to possible hazardous conditions. This manual uses a series of symbols and signal words intended to convey the level of importance of the safety messages. The progression of symbols is described below. Remember that safety messages by themselves do not eliminate danger and are not a substitute for proper accident prevention measures.



Indicates an imminently hazardous situation which, if not avoided, **WILL** result in death or serious injury.



Indicates a potentially hazardous situation which, if not avoided, **COULD** result in death or serious injury.



Indicates a potentially hazardous situation which, if not avoided, **MAY** result in minor or moderate injury. It may also be used to alert against unsafe practices.

NOTICE

This symbol is used to alert the user to useful information about proper operation of the machine.

WARNING

Safety Instructions for Machinery

- 1. READ ENTIRE MANUAL BEFORE STARTING.** Operating machine before reading the manual greatly increases the risk of injury.
- 2. ALWAYS USE ANSI APPROVED SAFETY GLASSES WHEN OPERATING MACHINERY.** Everyday eyeglasses only have impact resistant lenses—they are NOT safety glasses.
- 3. ALWAYS WEAR A NIOSH APPROVED RESPIRATOR WHEN OPERATING MACHINERY THAT PRODUCES DUST.** Most types of dust (wood, metal, etc.) can cause severe respiratory illnesses.
- 4. ALWAYS USE HEARING PROTECTION WHEN OPERATING MACHINERY.** Machinery noise can cause permanent hearing loss.
- 5. WEAR PROPER APPAREL. DO NOT** wear loose clothing, gloves, neckties, rings, or jewelry that can catch in moving parts. Wear protective hair covering to contain long hair and wear non-slip footwear.
- 6. NEVER OPERATE MACHINERY WHEN TIRED OR UNDER THE INFLUENCE OF DRUGS OR ALCOHOL.** Be mentally alert at all times when running machinery.



WARNING

Safety Instructions for Machinery

7. **ONLY ALLOW TRAINED AND PROPERLY SUPERVISED PERSONNEL TO OPERATE MACHINERY.** Make sure operation instructions are safe and clearly understood.
8. **KEEP CHILDREN/VISITORS AWAY.** Keep all children and visitors away from machinery. When machine is not in use, disconnect it from power, lock it out, or disable the switch to make it difficult for unauthorized people to start the machine.
9. **UNATTENDED OPERATION.** Leaving machine unattended while its running greatly increases the risk of an accident or property damage. Turn machine **OFF** and allow all moving parts to come to a complete stop before walking away.
10. **DO NOT USE IN DANGEROUS ENVIRONMENTS.** DO NOT use machinery in damp, wet locations, or where any flammable or noxious fumes may exist.
11. **KEEP WORK AREA CLEAN AND WELL LIGHTED.** Clutter and dark shadows may cause accidents.
12. **USE A GROUNDED POWER SUPPLY RATED FOR THE MACHINE AMPERAGE.** Grounded cords minimize shock hazards. Operating machine on an incorrect size of circuit increases risk of fire.
13. **ALWAYS DISCONNECT FROM POWER SOURCE BEFORE SERVICING MACHINERY.** Make sure switch is in OFF position before reconnecting.
14. **MAINTAIN MACHINERY WITH CARE.** Keep blades sharp and clean for best and safest performance. Follow instructions for lubricating and changing accessories.
15. **MAKE SURE GUARDS ARE IN PLACE AND WORK CORRECTLY BEFORE USING MACHINERY.**
16. **REMOVE CHUCK KEYS OR ADJUSTING TOOLS.** Make a habit of never leaving chuck keys or other adjustment tools in/on the machine—especially near spindles!
17. **DAMAGED MACHINERY.** Check for binding or misaligned parts, broken parts, loose bolts, other conditions that may impair machine operation. Always repair or replace damaged parts before operation.
18. **DO NOT FORCE MACHINERY.** Work at the speed for which the machine or accessory was designed.
19. **SECURE WORKPIECE.** Use clamps or a vise to hold the workpiece when practical. A secured workpiece protects your hands and frees both hands to operate the machine.
20. **DO NOT OVERREACH.** Maintain stability and balance at all times when operating machine.
21. **MANY MACHINES CAN EJECT WORKPIECES TOWARD OPERATOR.** Know and avoid conditions that cause the workpiece to "kickback."
22. **STABLE MACHINE.** Machines that move during operations greatly increase the risk of injury and loss of control. Verify machines are stable/secure and mobile bases (if used) are locked before starting.
23. **CERTAIN DUST MAY BE HAZARDOUS** to the respiratory systems of people and animals, especially fine dust. Be aware of the type of dust you are exposed to and always wear a respirator designed to filter that type of dust.
24. **EXPERIENCING DIFFICULTIES.** If at any time you are experiencing difficulties performing the intended operation, stop using the machine! Contact our Technical Support Department at (570) 546-9663.



WARNING

Additional Safety Instructions for Bandsaws

1. **BLADE CONDITION.** Do not operate with a dull, cracked, or badly worn blade. Dull blades require more effort to use and are difficult to control. Inspect blades for cracks and missing teeth before each use.
2. **HAND PLACEMENT.** Never position fingers or thumbs in line with the cut. Serious personal injury could occur.
3. **GUARDS.** Do not operate this bandsaw without the blade guard in place.
4. **BLADE REPLACEMENT.** When replacing blades, make sure the teeth face toward the front of the saw and the blade is properly tensioned before operating.
5. **WORKPIECE HANDLING.** Never hold small workpieces with your fingers when cutting. Always support/feed the workpiece with a push stick, table support, vise, or some type of clamping fixture.
6. **CUTTING TECHNIQUES.** Plan your cuts carefully. DO NOT back the workpiece away from the blade while the saw is running. If you need to back the work out, turn the bandsaw **OFF** and wait for the blade to come to a complete stop. DO NOT twist or put excessive stress on the blade while backing work away.
7. **BLADE SPEED.** Allow blade to reach full speed before cutting.
8. **LEAVING WORK AREA.** Never leave a machine running while unattended. Allow the bandsaw to come to a complete stop before leaving unattended.
9. **FEED RATE.** Always feed stock evenly and smoothly. DO NOT force or twist blade while cutting, especially when sawing tight curves.
10. **MAINTENANCE/SERVICE.** Do all inspections, adjustments, and maintenance with the machine turned **OFF** and disconnected from the power source.
11. **BLADE CONTROL.** Do not attempt to stop or slow the blade with your hand or a workpiece. Allow the blade to stop on its own.
12. **EXPERIENCING DIFFICULTIES.** If you experience difficulties performing the intended operation, stop using the machine and contact our Technical Support Department at (570) 546-9663.

WARNING

Like all machinery there is potential danger when operating this machine. Accidents are frequently caused by lack of familiarity or failure to pay attention. Use this machine with respect and caution to lessen the possibility of operator injury. If normal safety precautions are overlooked or ignored, serious personal injury may occur.

CAUTION

No list of safety guidelines can be complete. Every shop environment is different. Always consider safety first, as it applies to your individual working conditions. Use this and other machinery with caution and respect. Failure to do so could result in serious personal injury, damage to equipment, or poor work results.



SECTION 2: CIRCUIT REQUIREMENTS

220V Single-Phase Operation

!WARNING

Serious personal injury could occur if you connect the machine to power before completing the setup process. **DO NOT** connect the machine to the power until instructed later in this manual.



!WARNING

Electrocution or fire could result if machine is not grounded and installed in compliance with electrical codes. Compliance **MUST** be verified by a qualified electrician!

Full Load Amperage Draw

This machine draws the following amps under maximum load:

Amp Draw..... 5 Amps

Power Supply Circuit Requirements

The power supply circuit for your machine **MUST** be grounded and rated for the amperage given below. Never replace a circuit breaker on an existing circuit with one of higher amperage without consulting a qualified electrician to ensure compliance with wiring codes. **If you are unsure about the wiring codes in your area or you plan to connect your machine to a shared circuit, consult a qualified electrician.**

Minimum Circuit Size..... 15 Amps

Power Connection Device

The type of plug required to connect your machine to power depends on the type of service you currently have or plan to install. We recommend using the plug shown in **Figure 1**.

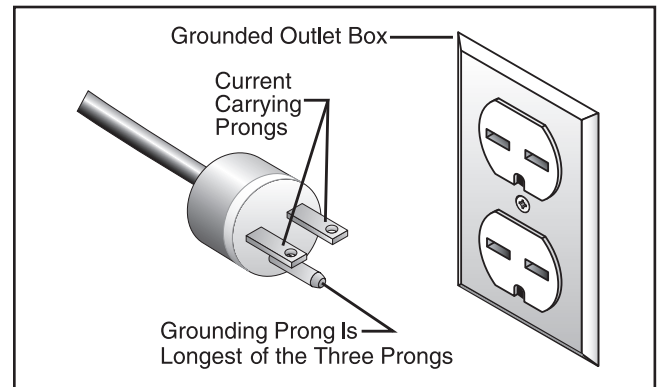

Figure 1. NEMA 6-15 plug and receptacle.

Extension Cords

Using extension cords may reduce the life of the motor. Instead, place the machine near a power source. If you must use an extension cord:

- Use at least a 14 gauge cord that does not exceed 50 feet in length!
- The extension cord must also have a ground wire and plug pin.
- A qualified electrician **MUST** size cords over 50 feet long to prevent motor damage.



SECTION 3: SETUP

Setup Safety

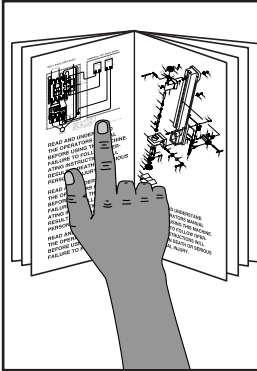

!WARNING

This machine presents serious injury hazards to untrained users. Read through this entire manual to become familiar with the controls and operations before starting the machine!

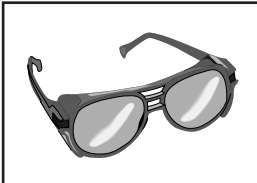

!WARNING

Wear safety glasses during the entire set up process!

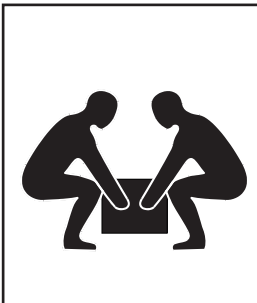

!WARNING

The Model G0621 is a heavy machine. DO NOT over-exert yourself while unpacking or moving your machine—get assistance.

Items Needed for Setup

The following items are needed to complete the setup process, but are not included with your machine:

Description	Qty
• Straightedge	1
• Level	1
• Another Person for Lifting Help	1
• Square	1
• Safety Glasses (for each person)	1
• Dust Collection System	1
• 2½" Dust Hose (length as needed)	1
• 2½" Hose Clamp	1

Unpacking

The Model G0621 was carefully packed when it left our warehouse. If you discover the machine is damaged after you have signed for delivery, *please immediately call Customer Service at (570) 546-9663 for advice.*

Save the containers and all packing materials for possible inspection by the carrier or its agent. *Otherwise, filing a freight claim can be difficult.*

When you are completely satisfied with the condition of your shipment, you should inventory the contents.



Inventory

After all parts have been removed from the two boxes, you should have the following items:

Main Components: (Figure 2)		Qty
A.	Bandsaw Unit	1
B.	6" Handwheel	1
C.	Handwheel Handle	1
D.	Miter Gauge.....	1
E.	Table	1
F.	Scale	1
G.	Table Insert	1
H.	Stand Door Knob $\frac{5}{16}$ "-18 x 1".....	1
I.	Dust Port 2½".....	1
J.	Table Trunnion Knobs $\frac{3}{8}$ "-16	2
K.	Rear Rail	1
L.	Front Rail.....	1
M.	Front Rail L-Brackets	2
N.	L-Bracket Knobs $\frac{5}{16}$ "-18 x $\frac{5}{8}$ ".....	2
O.	Fence Assembly.....	1
P.	Stand Assembly	1

Fasteners and Tools: (not shown)		Qty
•	Rubber Feet (Stand)	4
•	Hex Bolts $\frac{5}{16}$ "-18 x 1" (Feet)	4
•	Flat Washers $\frac{5}{16}$ " (Feet).....	4
•	Hex Nuts $\frac{5}{16}$ "-18 (Feet)	4
•	Hex Bolts $\frac{5}{16}$ "-18 x 3" (Stand/Bandsaw)	4
•	Flat Washers $\frac{5}{16}$ " (Stand/Bandsaw)	8
•	Hex Nuts $\frac{5}{16}$ "-18 (Stand/Bandsaw)	4
•	Hex Bolt $\frac{3}{8}$ "-16 x 3½" (Positive Stop)	1
•	Hex Nut $\frac{3}{8}$ "-16 (Positive Stop)	1
•	Cap Screws M6-1 x 16 (Front Rail).....	2
•	Front Rail T-Slot Nuts (Front Rail)	2
•	Cap Screws M6-1 x 16 (Rear Rail)	2
•	Guide Blocks (Blade Guides)	4
•	Thumbscrews ¼"-20 x ½" (Blade Guides) .	4
•	Phlp Hd Screws 10-24 x ¼" (Dust Port).....	4
•	Hex Wrenches 3, 5, 8mm	1 each
•	Flat Wrench 12/14mm.....	1

If any nonproprietary parts are missing (e.g. a nut or a washer), we will gladly replace them, or for the sake of expediency, replacements can be obtained at your local hardware store.

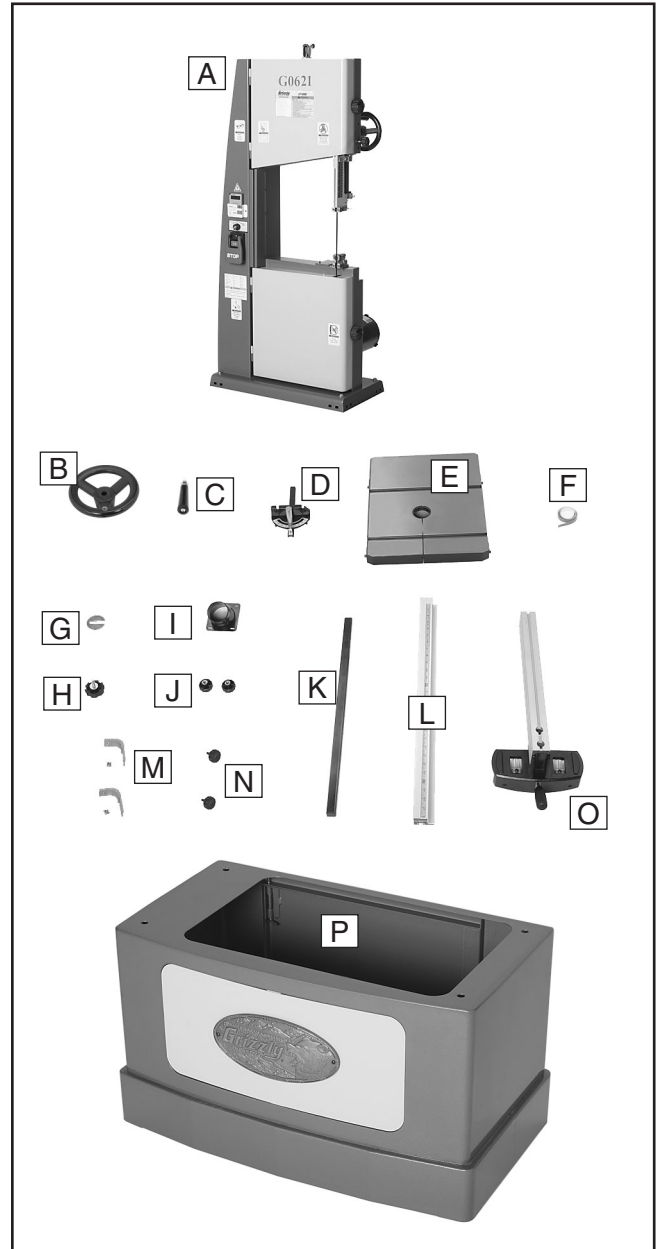

Figure 2. Main components inventory.

NOTICE

Some hardware/fasteners on the inventory list may arrive pre-installed on the machine. Check these locations before assuming that any items from the inventory list are missing.



Hardware Recognition Chart

USE THIS CHART TO MATCH UP HARDWARE DURING THE ASSEMBLY PROCESS.

MEASURE BOLT DIAMETER BY PLACING INSIDE CIRCLE

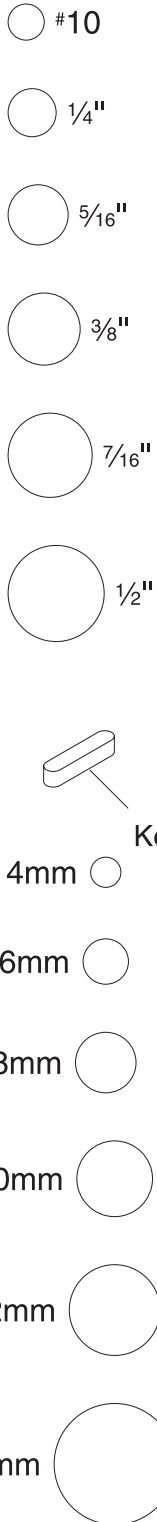

LINES ARE 1MM APART

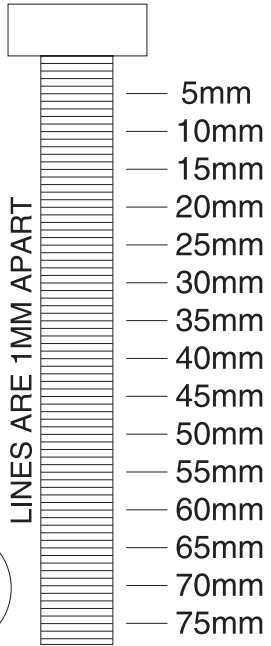

LINES ARE 1/16" INCH APART

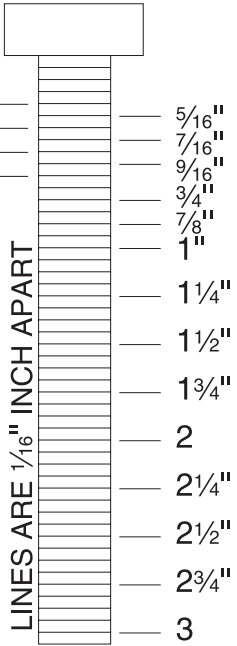

WASHERS ARE MEASURED BY THE INSIDE DIAMETER

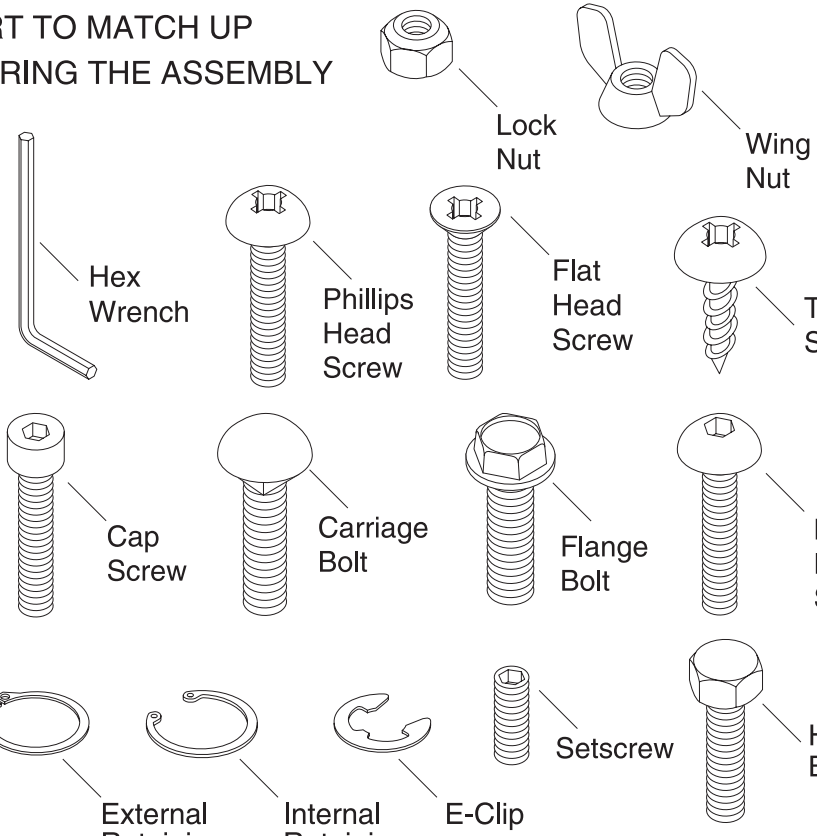
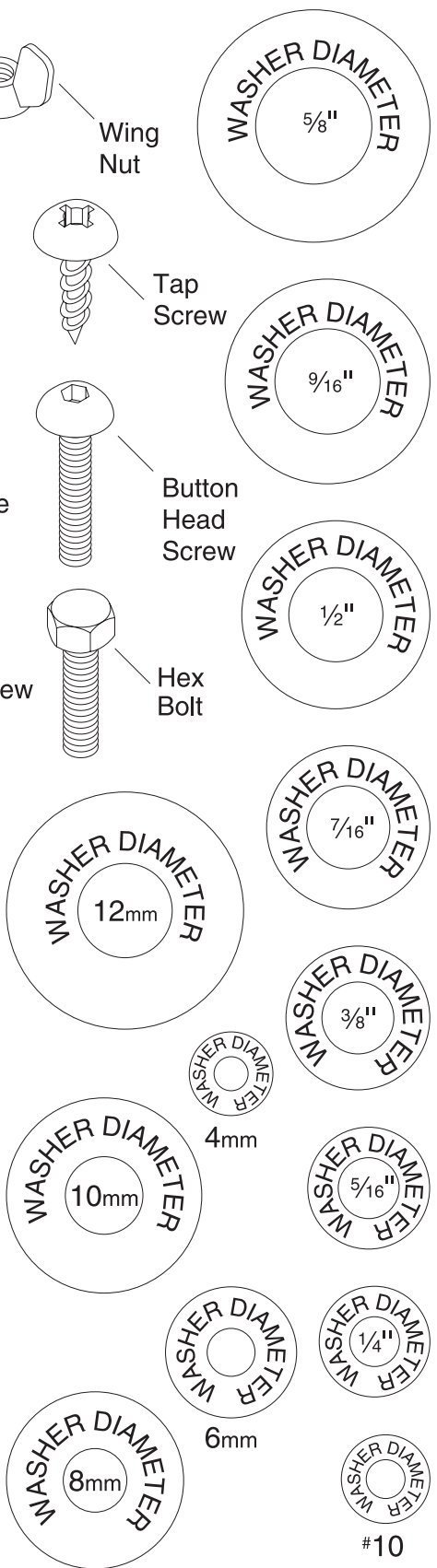

Cleanup

The unpainted surfaces of your machine are coated with a heavy-duty rust preventative that prevents corrosion during shipment and storage.

This rust preventative has been your machine's close ally and guardian since it left the factory. If your machine arrived to you free of rust, then be thankful that the rust preventative protected it during its journey...and try to stay thankful as you clean it off, because it can be challenging to remove if you are unprepared and impatient.

Plan on spending some time cleaning your machine. The time you spend doing this will reward you with smooth sliding parts and a better appreciation for the proper care of your machine's unpainted surfaces.

Although there are many ways to successfully remove the rust preventative, these instructions walk you through what works well for us.

Before cleaning, gather the following:

- Disposable Rags
- Cleaner/degreaser (see below)
- Safety glasses & disposable gloves

H9692—Orange Power Cleaner & Degreaser

One of the best cleaners we've found for quickly and easily removing rust preventative.

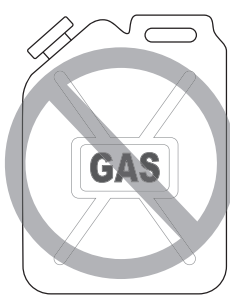

Figure 3. Model H9692 Industrial Orange Power Cleaner/Degreaser (99.9% biodegradable).

Note: *In a pinch, automotive degreasers, mineral spirits or WD•40 can be used to remove rust preventative. Before using these products, though, test them on an unnoticeable area of your paint to make sure they will not damage it.*

Model G0621 (Mfg. since 10/06)

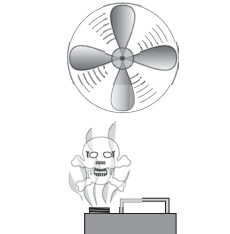

	⚠ WARNING Gasoline and petroleum products have low flash points and can explode or cause fire if used to clean machinery. Avoid using these products to clean machinery.
--	--

	⚠ CAUTION Many cleaning solvents are toxic if inhaled. Minimize your risk by only using these products in a well ventilated area.
--	---

NOTICE Avoid chlorine-based solvents, such as acetone or brake parts cleaner that may damage painted surfaces. Always follow the manufacturer's instructions when using any type of cleaning product.

Basic steps for removing rust preventative:

1. Put on safety glasses and disposable gloves.
2. Coat all surfaces that have rust preventative with a liberal amount of your cleaner/degreaser and let them soak for few minutes.
3. Wipe off the surfaces. If your cleaner/degreaser is effective, the rust preventative will wipe off easily.

Note: *To clean off thick coats of rust preventative on flat surfaces, such as tables, use a PLASTIC paint scraper to scrape off the majority of the coating before wiping it off with your rag. (Do not use a metal scraper or you may scratch your machine.)*

4. Repeat **Steps 2–3** as necessary until clean, then coat all unpainted surfaces with a quality metal protectant to prevent rust.

Site Considerations

Weight Load

Refer to the **Machine Data Sheet** for the weight of your machine. Make sure that the surface upon which the machine is placed will bear the weight of the machine, additional equipment that may be installed on the machine, and the heaviest workpiece that will be used. Additionally, consider the weight of the operator and any dynamic loading that may occur when operating the machine.

Space Allocation

Consider the largest size of workpiece that will be processed through this machine and provide enough space around the machine for adequate operator material handling or the installation of auxiliary equipment. With permanent installations, leave enough space around the machine to open or remove doors/covers as required by the maintenance and service described in this manual. **See below for working clearances.**

Physical Environment

The physical environment where your machine is operated is important for safe operation and the longevity of its components. For best results, operate this machine in a dry environment that is free from excessive moisture, hazardous chemicals, airborne abrasives, or extreme conditions. Extreme conditions for this type of machinery are generally those where the ambient temperature range exceeds 41°–104°F; the relative humidity range exceeds 20–95% (non-condensing); or the environment is subject to vibration, shocks, or bumps.

Electrical Installation

Place this machine near an existing power source. Make sure all power cords are protected from traffic, material handling, moisture, chemicals, or other hazards. Make sure to leave access to a means of disconnecting the power source or engaging a lockout/tagout device.

Lighting

Lighting around the machine must be adequate enough that operations can be performed safely. Shadows, glare, or strobe effects that may distract or impede the operator must be eliminated.

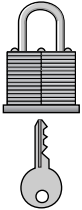
	<p>CAUTION Children or untrained people may be seriously injured by this machine. Only install in an access restricted location.</p>
---	---

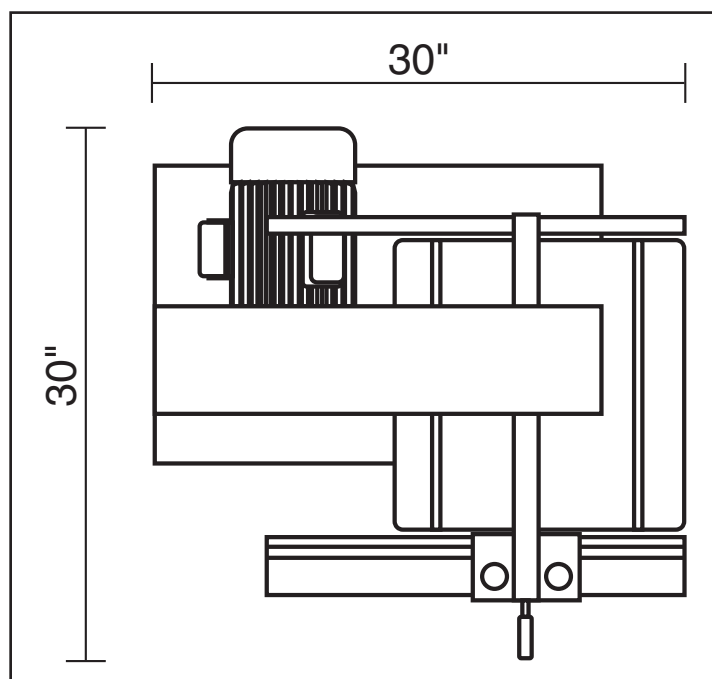

Figure 4. Minimum working clearances.



Assembly

To assemble the bandsaw:

1. Install the rubber feet into the bottom of the cabinet stand, as shown in **Figure 5**, with the four $\frac{5}{16}$ "-18 x 1" hex bolts, four $\frac{5}{16}$ " flat washers, and four $\frac{5}{16}$ "-18 hex nuts.

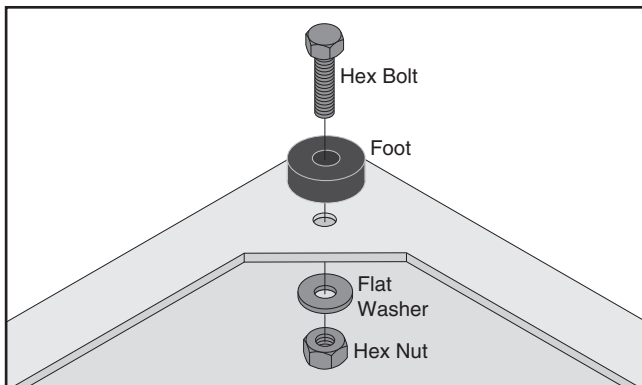
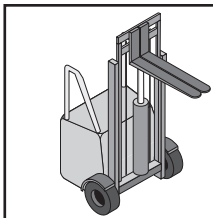

Figure 5. Rubber foot order of installation.



CAUTION
The bandsaw is heavy and awkward to lift. Use a forklift or other powered lifting aid.

2. Using a forklift or other powered lifting aid, place the bandsaw on top of the stand.
3. Align the mounting holes on the bandsaw base with those in the stand.
4. Secure the bandsaw to the stand with the four $\frac{5}{16}$ "-18 x 3" hex bolts, eight $\frac{5}{16}$ " flat washers, and four $\frac{5}{16}$ "-18 hex nuts (**Figure 6**).



Figure 6. Bandsaw mounted to stand.

5. Thread a $\frac{3}{8}$ "-16 hex nut half way up the positive stop bolt (Hex Bolt $\frac{3}{8}$ "-16 x $3\frac{1}{2}$ ").
6. Thread the positive stop bolt into the trunnion base so it is installed as shown in **Figure 7**.

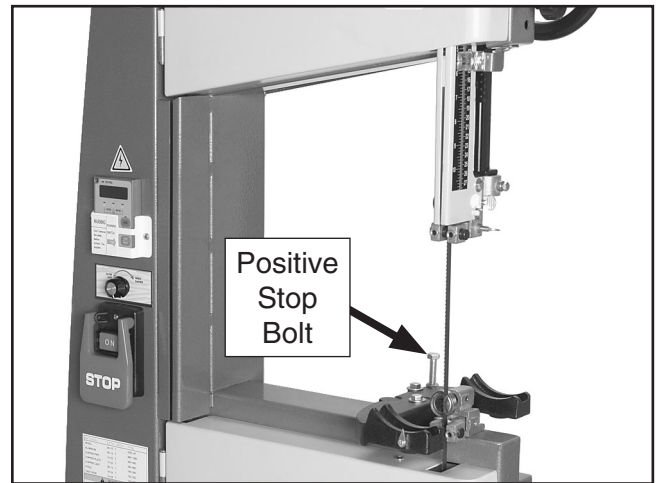

Figure 7. Positive stop bolt installed.

7. Remove the table pin from the table.
8. Fit the table around the blade and rest the table trunnions on the trunnion base, making sure the trunnion bolts extend through the bottom of the trunnion base.
9. Thread the two table trunnion knobs onto the trunnion bolts, as illustrated in **Figure 8**.

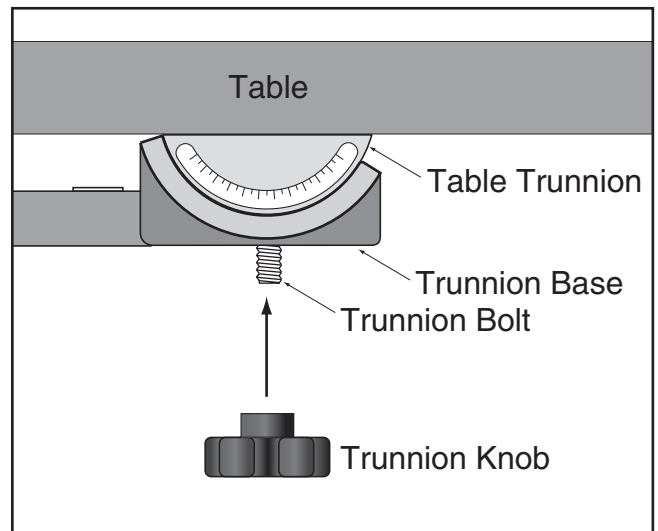

Figure 8. Table installation on trunnion base.



10. Place the table insert in the center of the table, so it sits flush with the table top surface.
11. Insert the pin into the end of the table slot.
12. Attach the rail brackets to the front of the table with the two M6-1 x 16 cap screws, as shown in **Figure 9**.

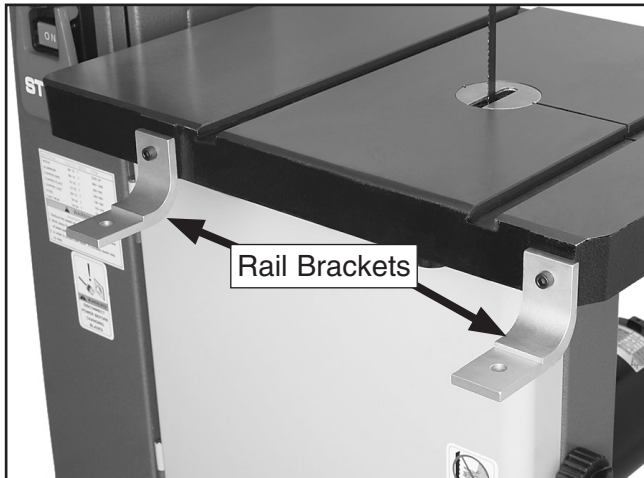

Figure 9. Rail brackets attached to table.

13. Slide the front rail nuts into the T-slot on the underside of the front rail.
14. Fasten the front fence rail to the rail brackets with the two rail bracket knobs, as shown in **Figure 10**, going into the front rail nuts.



Figure 10. Fastening front fence rail.

15. Fasten the rear fence rail to the back of the bandsaw with two M6-1 x 16 cap screws, as shown in **Figure 11**.

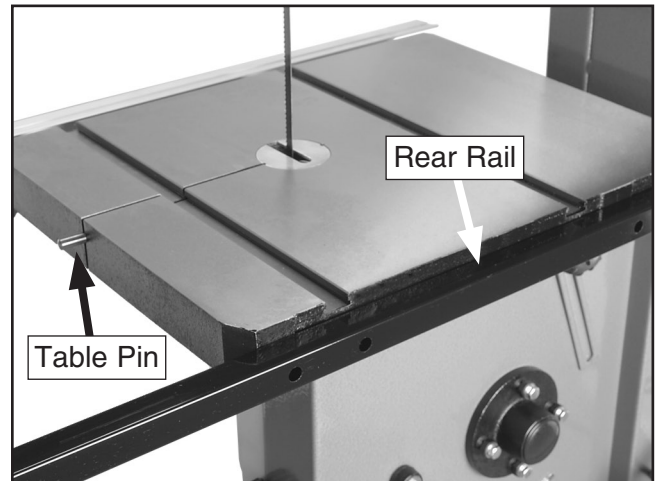

Figure 11. Rear fence rail attached to table.

16. Pull the fence handle up and place the fence on the front fence rail, as shown in **Figure 12**.

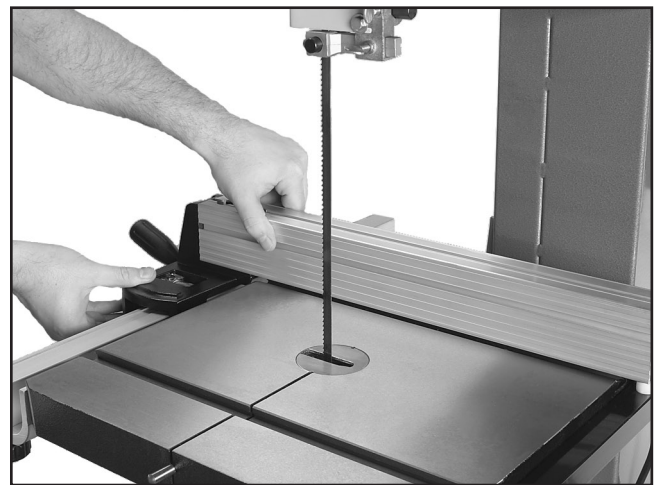

Figure 12. Installing fence onto rails.

17. Push the fence handle down to lock the fence in position.



- Use the tilt bracket knob to secure the table tilt bracket to the bandsaw body, as shown in **Figure 13**. Tighten the hex nut on the tilt bracket knob against the tilt bracket to secure it in place.

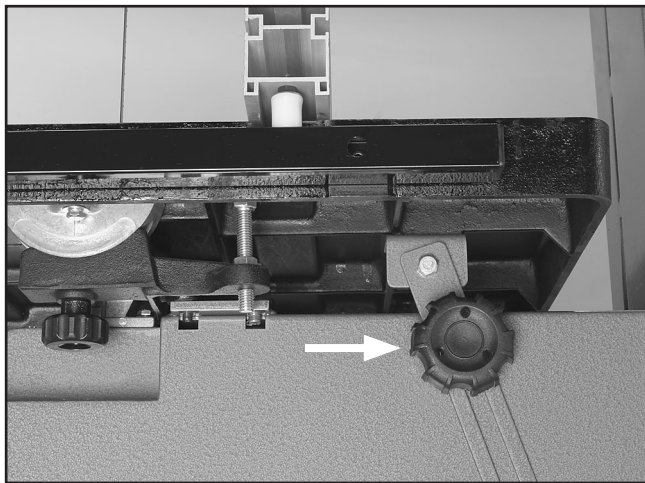

Figure 13. Knob securing table tilt bracket.

- Thread the handle into the handwheel, then tighten the hex nut against the handwheel to secure it in place.
- Install the 6" handwheel, as shown in **Figure 14**, by placing it on the shaft and tightening the set screw in the handwheel.

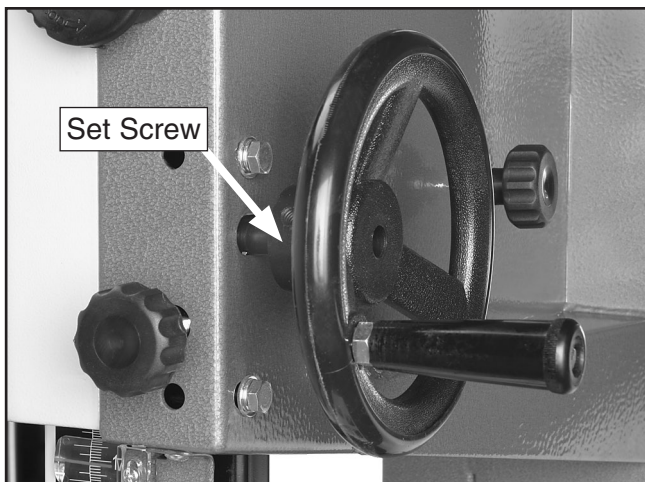

Figure 14. 6" Handwheel installed.

- Slide the fence against the blade.
- Use a sharp pencil to mark the fence rail where the fence scale indicator is pointing. This mark will indicate where to align the 0" mark when you install the scale.
- Remove the fence from the front rail.

Model G0621 (Mfg. since 10/06)

- Carefully install the scale on the front fence rail, as shown in **Figure 15**, so the 0" mark on the scale lines up with the pencil mark made in **Step 22**.



Figure 15. Scale installed on front fence rail.

- Insert the guide blocks into the upper and lower blade guide assemblies, then secure them with the 1/4"-20 x 1/2" thumbscrews, as shown in **Figure 16**.

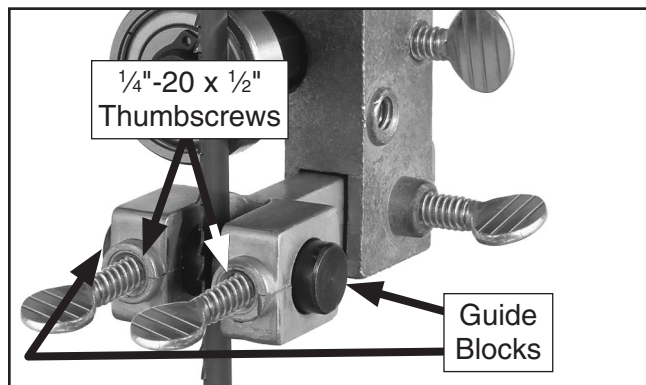

Figure 16. Blade guide installation.

- Install the dust port, as shown in **Figure 17**, with the four 10-24 x 1/4" Phillips head screws.

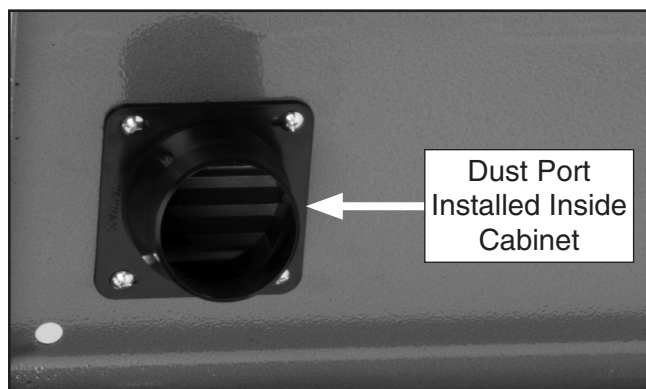

Figure 17. Dust port installation.



Dust Collection

⚠ CAUTION

This saw creates substantial amounts of fine dust while operating. Failure to use a vacuum system can result in respiratory illness.

Connect this machine to a shop vacuum rather than a dust collector. Most dust collectors are not designed to capture metal shavings and doing so may lead to a fire. If you are in doubt about the capabilities of your shop vacuum or dust collector, refer the owner's manual before connecting it to this machine.

To connect a vacuum hose:

1. Fit the 2½" dust hose over the dust port, as shown in **Figure 18**, and secure in place with a hose clamp.
2. Tug the hose to make sure it is snug.

Note: *A tight fit is necessary for proper performance.*

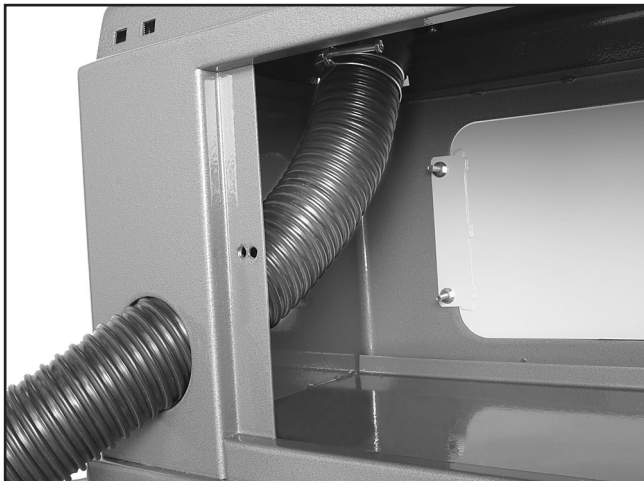

Figure 18. Dust hose attached to dust port.

3. Close stand door and fasten it shut with the stand door knob.

Blade Tracking

"Blade Tracking" refers to how the blade rides on the wheels. When tracking correctly, the blade rides in the center of the rim part of the wheels.

Blade tracking is primarily controlled by adjusting the upper wheel tilt. Tracking the blade in this manner is referred to as "Center Tracking," because you tilt the wheel until the blade rides in the center.

Another way to track the blade is known as "Coplanar Tracking." Coplanar tracking involves aligning the wheels so they are parallel and aligned (see **Wheel Alignment** on **Page 43**). When wheels are coplanar, vibration and heat are reduced during operation.

The wheels on the Model G0621 are factory aligned, so center tracking is the only adjustment that needs to be performed during setup.

To center track the blade:

1. DISCONNECT BANDSAW FROM POWER!
2. Adjust the upper/lower blade guides and support bearings away from the blade.
3. Open the upper wheel cover.
4. Adjust the blade tension by matching the size of the installed blade with the equivalent mark on the blade tension scale (located on the back of the bandsaw).
5. Spin the upper wheel by hand at least three times and watch how the blade rides on the crown of the wheel. Refer to **Figure 19** for an illustration of this concept.

—If the blade rides on the peak of the upper wheel crown, then the bandsaw is already tracked properly and no additional adjustments are needed. Skip to **Step 9**.

—If the blade does not ride in the peak of the upper wheel crown, then continue with the next step.



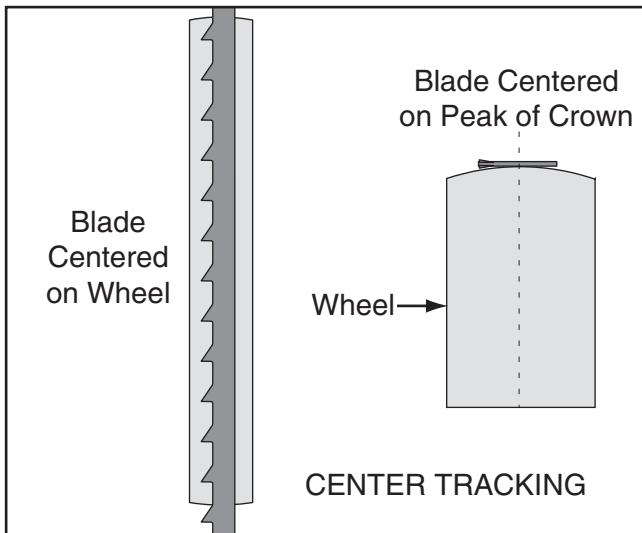

Figure 19. Center tracking profiles.

6. Loosen the lock nut on the blade tracking knob threads so the blade tracking knob will rotate for adjustments.
7. Spin the upper wheel with one hand and rotate the blade tracking knob with the other hand to make the blade ride in the center of the bandsaw wheel tire.
8. When the blade consistently rides in the center of the wheel, tighten the tracking control lock nut.
9. Close the upper wheel cover.

Note: For the best performance from your saw, regularly maintain proper blade tracking.

NOTICE

Changes in the blade tension may change the blade tracking.

Test Run

Once assembly is complete and you have performed the **Blade Tracking** steps on **Page 18**, test run the machine before continuing with the remainder of the adjustments.

If, during the test run, you cannot easily locate the source of an unusual noise or vibration, stop the machine immediately, then review **Troubleshooting** on **Page 38**.

If you still cannot remedy a problem, contact our Tech Support at (570) 546-9663 for assistance.

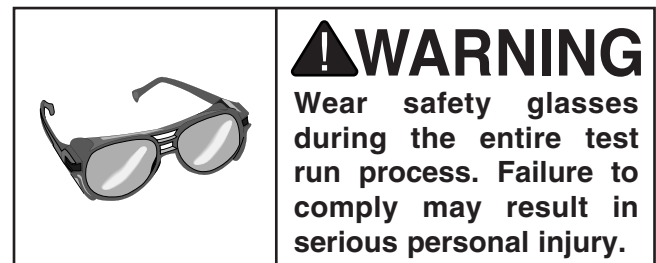

To test run the machine:

1. Read the **Safety** section beginning on **Page 6** and read **Basic Controls** on **Page 25**.
2. Connect the machine to the power source.
3. Turn the speed dial counterclockwise as far as it will go.
4. Lift the STOP paddle on the power switch and press the STOP button all the way in (this resets the safety mechanism on the STOP switch).
5. Turn the power **ON** by pressing the green ON button above the STOP paddle. The digital display should light up. If not, make sure the power STOP switch has been reset; otherwise, check the electrical connections and power source.
6. Press the ON button located on the motor control switch, then slowly turn the speed dial clockwise.
7. Listen to and watch for abnormal noises or actions. The machine should run smoothly with little or no vibration or rubbing noises.

—Strange or unusual noises must be investigated and corrected before operating the machine further. Always turn **OFF** the machine and disconnect it from power before investigating or correcting potential problems.



Tensioning Blade

A properly tensioned blade is essential for making accurate cuts and is a prerequisite for making many bandsaw adjustments. The blade tension is adjusted by rotating the blade tension lever.

To tension the bandsaw blade:

1. Make sure you have performed the **Test Run** instructions on the previous page and you are certain that the blade is tracking properly.
2. With the blade tension lever in the down (engaged) position, adjust the blade tension until the mark on the blade tension scale matches the size of blade installed on the bandsaw.

Note: *Because each blade is different and all blades stretch, this scale can only be considered as a general guide.*

3. Turn the bandsaw **ON**.
4. Release the tension one quarter of a turn at a time. When the bandsaw blade starts to flutter, stop decreasing the tension.
5. Now, slowly increase the tension until the blade stops fluttering, then tighten the tension one more quarter of a turn.
6. Turn the bandsaw **OFF** and read the tension gauge. Use the reading as a guide when tensioning that blade in the future.

Note: *Do not rely on this measurement for long periods of time because the blade will stretch with use.*

NOTICE

To reduce blade stretching, remove the tension from the blade when not in use.

NOTICE

After blade tension and tracking are set correctly, properly adjust the upper/lower support bearings and guide-block assemblies into position before operating machine.

Adjusting Support Bearings

The support bearings are positioned behind the blade to support it during cutting operations. Proper adjustment of the support bearings is an important part of making accurate cuts and also keeps the blade teeth from hitting the blade guides during cuts.

To adjust the support bearings:

1. Make sure that the blade is tracking properly and that it is correctly tensioned.
2. **DISCONNECT BANDSAW FROM POWER!**
3. Familiarize yourself with the support bearing controls shown in **Figure 20**.

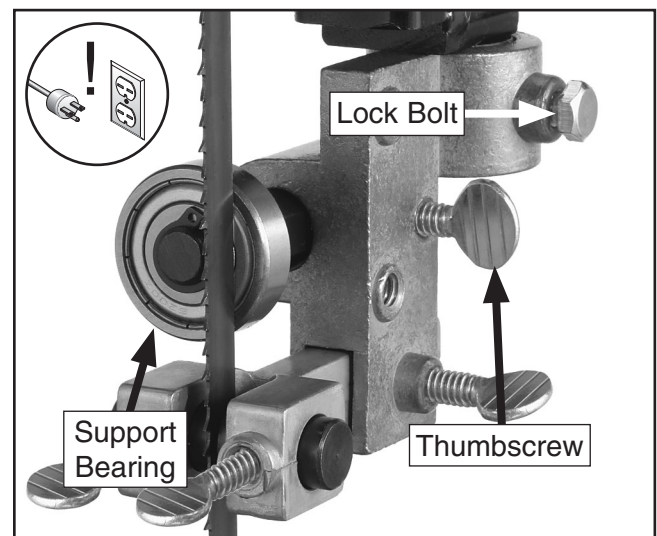

Figure 20. Support bearing controls.

4. Remove the blade guard.
5. Loosen the lock bolt shown in **Figure 20**.



- Look at the face of the support bearing and rotate the blade guide assembly side-to-side, until the blade is perpendicular with the face of the support bearing, as illustrated in **Figure 21**.

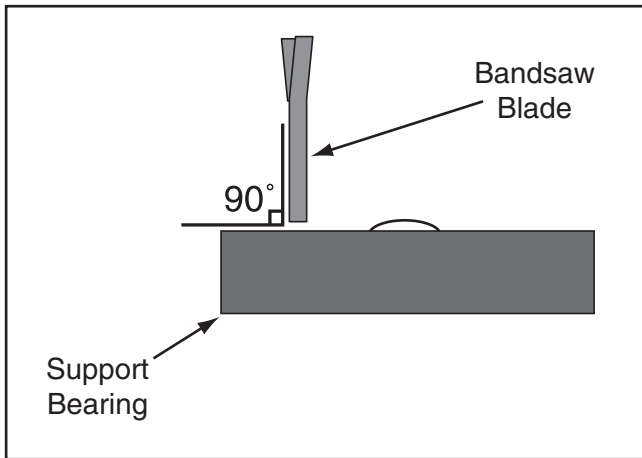

Figure 21. Blade should be perpendicular (90°) to the face of the support bearing.

- Tighten the lock bolt.
- Loosen the thumbscrew on the support bearing adjustment shaft.
- Position the support bearing approximately 0.016" away from the back of the blade as illustrated in **Figure 22**.

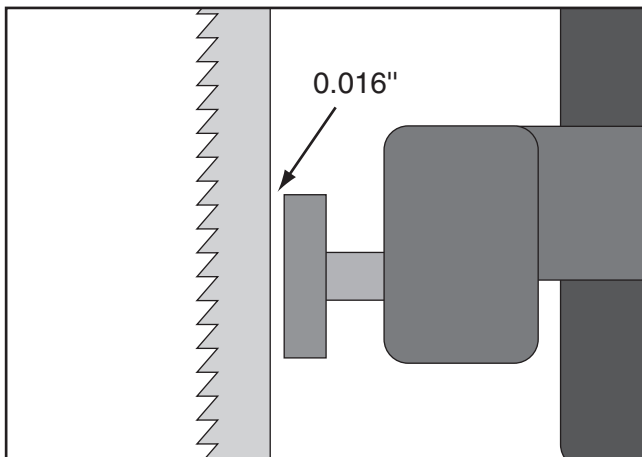

Figure 22. Blade should be aligned approximately 0.016" away from the bearing edge.

- To quickly gauge this setting, fold a dollar bill in half twice (when folded tightly, four thicknesses of a dollar bill is approximately 0.016"). Place the folded dollar bill between the support bearing and the blade as shown in **Figure 23**.

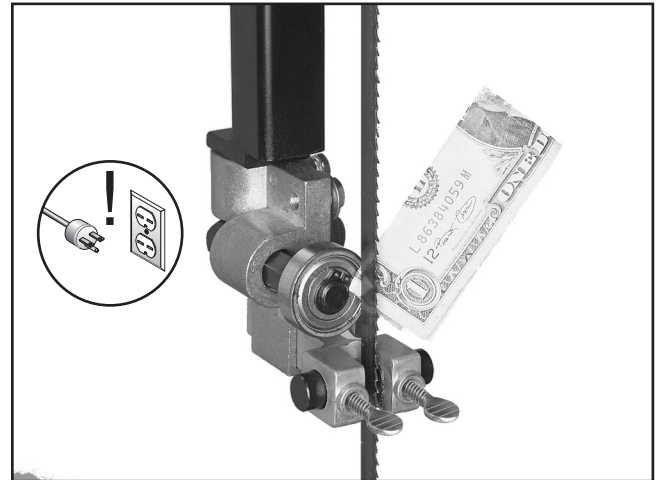

Figure 23. Dollar bill folded twice to make a quick 0.016" gauge.

- Tighten the thumbscrew to lock the support bearing in place.

NOTICE

Whenever changing a blade or adjusting tension and tracking, the upper and lower blade support bearings and guide-blocks must be re-adjusted before cutting operations.



Adjusting Blade Guides

The blade guides provide side-to-side support to help keep the blade straight while cutting. The blade guides adjust in two ways—forward/backward and side-to-side. Properly adjusted blade guides are essential to making accurate cuts.

To adjust the upper and lower blade guides:

1. Make sure the blade tracks properly and is correctly tensioned.
2. DISCONNECT BANDSAW FROM POWER!
3. Familiarize yourself with the blade guide controls shown in **Figure 24**.

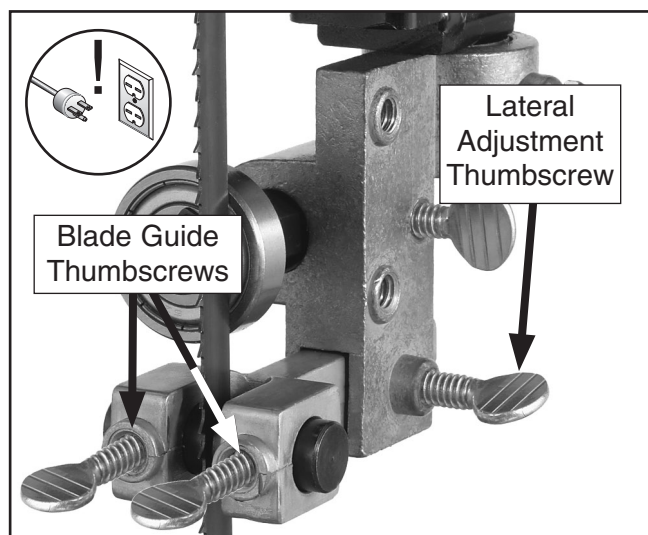

Figure 24. Blade guide controls.

4. Loosen the lateral adjustment thumbscrew.
5. Slide the guide assembly so the front edges of the blade guides are just behind the blade gullets as illustrated in **Figure 25**.

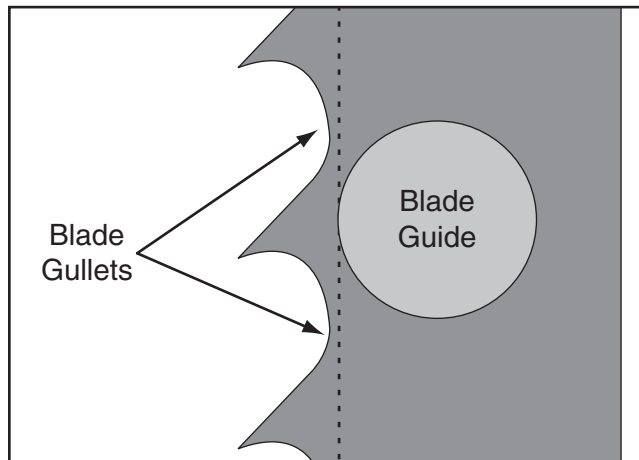

Figure 25. Lateral adjustment of blade guides.

NOTICE

Make sure the blade teeth will not contact the blade guides during operations or the tooth set on the blade will be ruined.

6. Tighten the lateral adjustment thumbscrew.
7. Loosen the blade guide thumbscrews.
8. Fold a crisp dollar bill in half and place it over the blade (between the blade guides and the blade), as shown in **Figure 26**.

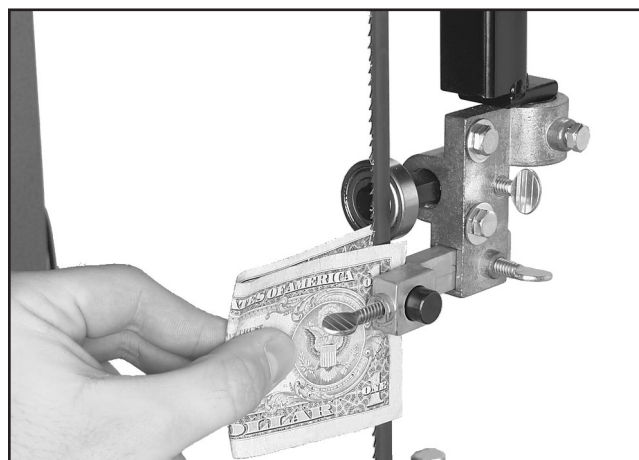

Figure 26. Blade guides against both sides of blade.

9. Lightly pinch the dollar bill against the blade with the blade guides, then tighten the blade guide thumbscrews.
10. Remove the dollar bill, then re-install the blade guard.



NOTICE

The blade guides should not touch the blade after the dollar bill is removed.

NOTICE

Whenever changing a blade or adjusting tension and tracking, the upper and lower blade guides and guide-blocks must be re-adjusted before cutting operations.

Adjusting Positive Stop

An adjustable positive stop allows the table to easily return to 90° after tilting.

To set the positive stop 90° to the blade:

1. Make sure the blade is correctly tensioned as described in the **Tensioning Blade** instructions on **Page 20**.
2. **DISCONNECT BANDSAW FROM POWER!**
3. Loosen the two plastic knobs that secure the table to the trunnions.
4. Loosen the hex nut that locks the positive stop bolt in place.
5. Raise the upper blade guide assembly and place a 6" machinist's square or try-square on the table next to the side of the blade as illustrated in **Figure 27**. Adjust the positive stop bolt to raise or lower the table until the table is 90° to the blade.

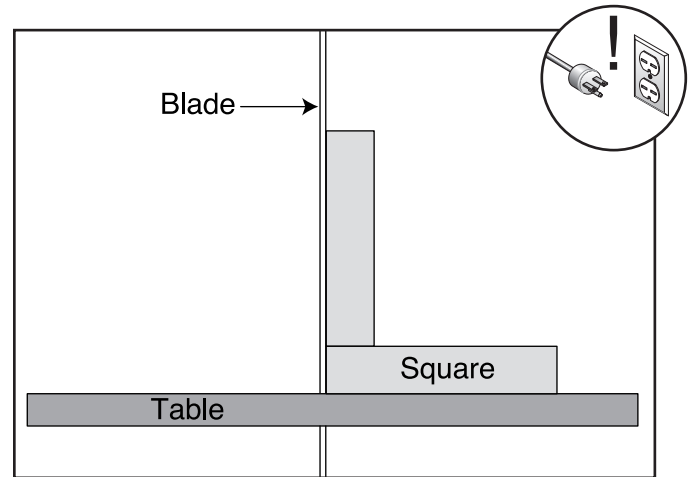

Figure 27. Squaring table to blade.

6. Secure the plastic knobs and lock the positive stop bolt by tightening the hex nut against the casting. *Ensure that the bolt does not turn by holding it with another wrench while tightening the hex nut.*

Setting Table Tilt Scale to 0°

The pointer on the table tilt scale must be calibrated in order for the scale reading to be accurate.

To calibrate the pointer on the table tilt scale:

1. Make sure the blade is tensioned/tracking correctly and that the table is 90° to the blade (this procedure should be already completed with the **Adjusting Positive Stop** instructions).
2. Loosen the pointer screw.
3. Align the tip of the pointer with the 0° mark on the table tilt scale.
4. Tighten the pointer screw.



Aligning Table

To ensure cutting accuracy when the table is first installed, the table should be aligned so the miter slot is parallel to the bandsaw blade. *This procedure works best with a 3/4" blade.*

To align the miter slot parallel to the bandsaw blade:

1. Make sure the blade is tracking properly and that it is correctly tensioned.
2. DISCONNECT BANDSAW FROM POWER!
3. Loosen the trunnion bolts that secure the trunnions to the table.
4. Place an accurate straightedge along the blade. The straightedge should lightly touch both the front and back of the blade (the flat part only) without touching the blade teeth.
5. Use a fine ruler to gauge the distance between the straightedge and the miter slot. The distance you measure should be the same at both the front and back ends of the miter slot.
6. Adjust the table as needed until the distance between the blade and miter slot is equal at both ends.
7. Tighten the trunnion bolts.

Aligning Fence

To ensure cutting accuracy, the fence must be parallel with the miter slot.

To align the fence parallel with the miter slot:

1. If the fence is mounted on the left-hand side of the blade, remove it and remount it on the right-hand side of the blade.
2. Adjust the fence face parallel with the edge of the miter slot.
3. Loosen the two cap screws that mount the front rail to the table.
4. Place shims between the front rail and the table as necessary to make the fence parallel with the miter slot.

Note: *Shim stock works well for this, but small pieces of paper can also work in a pinch.*
5. Tighten the front rail mounting bolts.

NOTICE

Adjusting the fence parallel to the miter slot does not guarantee straight cuts. The miter slot may need to be adjusted parallel to the side of the blade. Refer to the Aligning Table instructions.



SECTION 4: OPERATIONS

Operation Safety

! WARNING

Damage to your eyes, lungs, and ears could result from using this machine without proper protective gear. Always wear safety glasses, a respirator, and hearing protection when operating this machine.

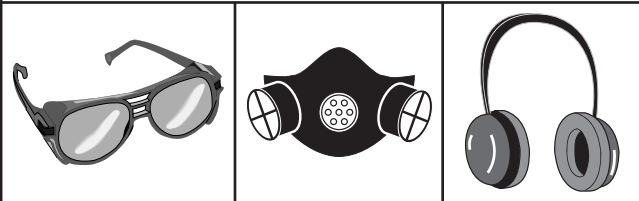

! WARNING

Loose hair and clothing could get caught in machinery and cause serious personal injury. Keep loose clothing and long hair away from moving machinery.

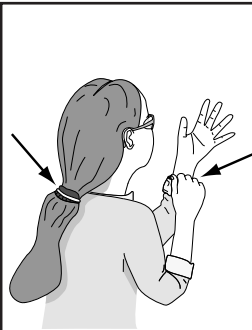

NOTICE

If you have never used this type of machine or equipment before, WE STRONGLY RECOMMEND that you read books, trade magazines, or get formal training before beginning any projects. Regardless of the content in this section, Grizzly Industrial will not be held liable for accidents caused by lack of training.

Basic Controls

Motor Switch: Starts and stops the motor. Only works after the power switch has been reset and turned **ON**.

Speed Dial: Adjusts the speed of the motor, which is displayed in RPM on the digital display.

Power Switch: Turns power ON/OFF to the motor switch. OFF button must be reset (by pushing it all the way in) before power will turn **ON** again.

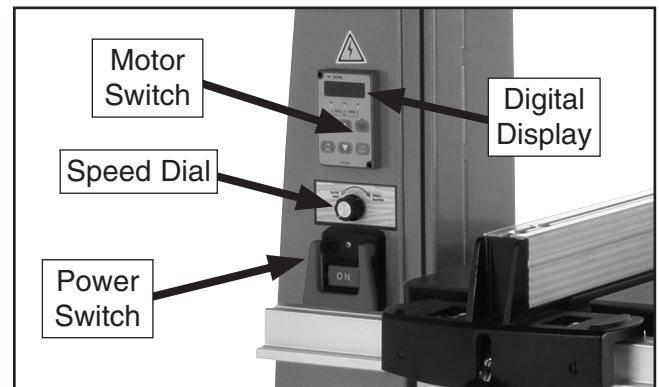

Figure 28. Motor, speed, and power controls.

Blade Tension Handle: Increases/decreases blade tension when rotated. Quickly releases blade tension when pivoted up.

Blade Guide Elevation Handwheel: Raises/lowers the upper blade guide assembly when rotated. The blade guide assembly should always be within 1" of the workpiece when cutting.

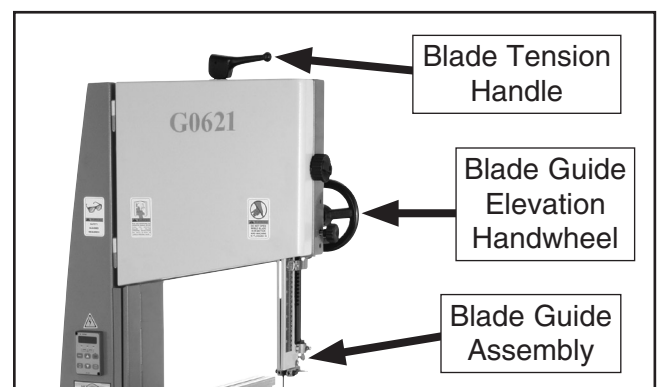

Figure 29. Blade tension/guide post controls.



Workpiece Inspection (Wood)

Some wood workpieces are not safe to cut or may require modification before they are safe to cut.

Before cutting wood, get in the habit of inspecting all workpieces for the following:

- **Foreign Objects:** Nails, staples, dirt, rocks and other foreign objects are often embedded in wood. While cutting, these objects can become dislodged and hit the operator or break the blade, which might then fly apart. Always visually inspect your workpiece for these items. If they can't be removed, do NOT cut the workpiece.
- **Large/Loose Knots:** Loose knots can become dislodged during the cutting operation. Large knots can cause blade damage. Choose workpieces that do not have large/loose knots or plan ahead to avoid cutting through them.
- **Wet or "Green" Stock:** Cutting wood with a moisture content over 20% causes unnecessary wear on the blade and yields poor results.
- **Excessive Warping:** Workpieces with excessive cupping, bowing, or twisting are dangerous to cut because they are unstable and can move unpredictably when being cut. DO NOT use workpieces with these characteristics!
- **Minor Warping:** Workpieces with slight cupping can be safely supported if the cupped side faces the table or fence. On the contrary, a workpiece supported on the bowed side will rock during a cut, leading to loss of control.

Overview

The bandsaw is one of the most versatile wood cutting tools in the shop. It is capable of performing the following types of cuts:

Straight Cuts

- Mitters
- Angles
- Compound Angles
- Resawing
- Ripping
- Crosscutting

Irregular Cuts

- Simple and Complex Curves
- Duplicate Parts
- Circles
- Beveled Curves

Basic Cutting Tips

Follow these basic tips when operating the bandsaw:

- Keep the upper blade guide assembly adjusted to within 1" of the workpiece.
- Replace, sharpen, and clean blades as necessary. Make adjustments periodically to keep the saw running in top condition.
- Use light and even pressure while cutting. Light contact with the blade makes it easier to follow lines and prevents extra friction.
- Avoid twisting the blade when cutting around tight corners. Allow the blade to saw around the corners.
- Misusing the saw or using incorrect techniques is unsafe and results in poor cuts. Remember—the blade does the cutting with the operator's guidance.
- Never start a cut with the blade in contact with the workpiece, and do not start a cut on a sharp edge.



- When cutting metal, pay attention to the characteristics of the chips when cutting—they are good indicators of proper blade speed and feed rate. **Figure 30** shows the basic chip characteristics and what they mean.

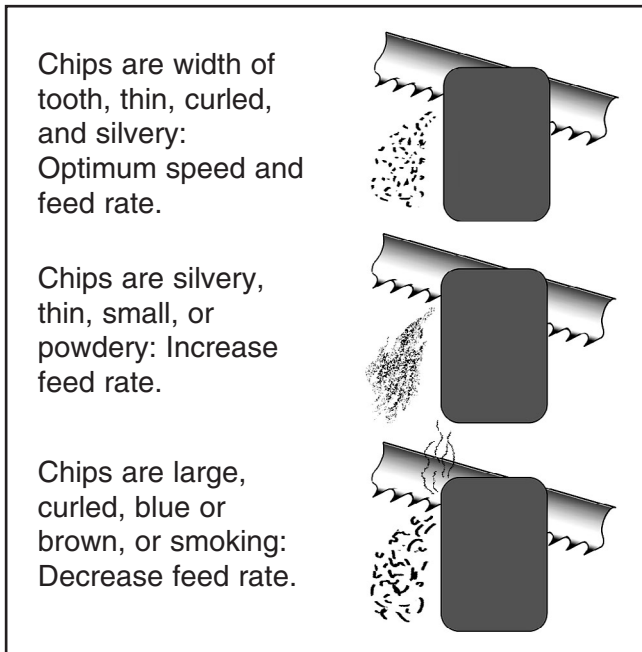

Figure 30. Reading chip characteristics.

Table Tilt

The bandsaw table tilts from -5° left to 45° right.

To tilt the table:

- Loosen the two trunnion knobs underneath the table.
- Tilt the table to the desired angle. (Refer to the angle gauge on the front table trunnion.)
- Retighten both table-trunnion knobs.

NOTICE

The positive stop must be removed to move the table to the left.

Guide Post

The guide post (shown in **Figure 31**) connects the upper blade guide assembly to the bandsaw. The guidepost allows the blade guide assembly to move up or down to be as close to the workpiece as possible. In order to cut accurately and safely, the bottom of the blade guide assembly must be no more than 1" from the workpiece at all times—this positioning provides the greatest blade support and minimizes the amount of moving blade exposed to the operator.

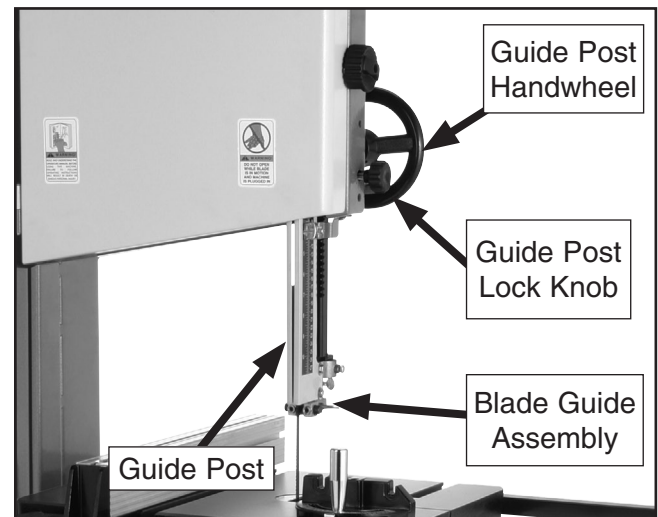

Figure 31. Guide post controls.

To adjust the blade guide assembly on the guide post (the bandsaw must be turned OFF):

- Make sure that the blade tension, blade tracking, support bearing, and blade guides are adjusted correctly.
- Loosen the guide post lock knob shown in **Figure 31**.
- Raise/lower the guide post so the bottom of the blade guide assembly is less than 1" from the top of the workpiece.
- Lock the guide post with the lock knob.



Ripping

When cutting wood, "Ripping" means cutting with the grain. For plywood or metal, ripping simply means cutting down the length of the workpiece.

To make a rip cut:

1. Adjust the fence to match the width of the cut on your workpiece, then lock the fence in place.
2. Adjust the blade guide assembly to less than 1" away from the workpiece.
3. After all safety precautions have been met, turn the bandsaw **ON**. Slowly feed the workpiece into the blade and continue with the cut until the blade is completely through the workpiece. **Figure 32** shows a typical ripping operation.

Note: *If you cut narrow pieces, use a push stick to protect your fingers.*



Figure 32. Typical ripping operation.

⚠️ WARNING

NEVER place fingers or hands in the line of cut. If you slip, your hands or fingers may go into the blade. **ALWAYS** use a push stick when ripping narrow pieces. Failure to follow these warnings may result in serious personal injury!

Crosscutting

"Crosscutting" means cutting across the grain of wood. For plywood or metal, crosscutting simply means cutting across the width of the workpiece.

To make a 90° crosscut:

1. Mark the workpiece on the edge where you want to begin the cut.
2. Adjust the blade guide assembly to to less than 1" away from the workpiece and make sure the miter gauge is set to 90°.
3. Move the fence out of the way. Place the workpiece evenly against the miter gauge.
4. Hold the workpiece against the miter gauge and align the mark with the blade.
5. After all safety precautions have been met, turn the bandsaw **ON**. Slowly feed the workpiece into the blade and continue the cut until the blade is all the way through the workpiece. **Figure 33** shows a typical crosscutting operation.



Figure 33. Typical crosscutting operation.



Resawing

"Resawing" (**Figure 34**) means cutting the workpiece into two or more thinner workpieces.

One of the most important considerations for resawing is blade selection—a wide blade cuts straighter and is less prone to blade lead (see **Page 42** for more info on blade lead).

For most applications, use a blade with a hook or a skip tooth style. Choose blades with fewer teeth-per-inch (from 3 to 6), because they offer larger gullet capacities for clearing sawdust, reducing heat buildup and reducing strain on the motor.



Figure 34. Typical resawing operation.

!WARNING

When resawing thin pieces, a wandering blade (blade lead) can tear through the side of the workpiece, exposing your hands to the blade teeth. Always use push blocks when resawing and keep your hands clear of the blade.

To resaw a workpiece:

1. Verify that the bandsaw is setup properly and that the table is perpendicular to the blade.
2. Use the widest blade your bandsaw will accept. **Note:** *The blade must also be sharp and clean.*
3. Adjust the fence to the desired width of cut, and lock it in place.

NOTICE

The scale on the front rail will NOT be accurate when using the resaw fence.

4. Support the ends of the board if necessary.
5. Turn the bandsaw **ON**.
6. Using push paddles and a push stick, maintain workpiece pressure against the fence and table, and slowly feed the workpiece into the moving blade until the blade is completely through the workpiece (see **Figure 34**).



Cutting Curves

When cutting curves, simultaneously feed and turn the stock carefully so the blade follows the layout line without twisting. If a curve is so abrupt that it is necessary to repeatedly back up and cut a new kerf, use a narrower blade, a blade with more TPI (teeth per inch), or make more relief cuts.

Relief cuts are made through the waste portion of the workpiece and stop at the layout line. Relief cuts reduce the chance that the blade will be pinched or twisted during the cut.

The list below shows the minimum radius that can be cut by common blade widths.

Width	Radius
1/8"	1/8"
3/16"	3/8"
1/4"	5/8"
3/8"	1 1/4"
1/2"	2 1/2"
5/8"	3 3/4"
3/4"	5 1/2"

Figure 35. Blade width radii.

Stacked Cuts

One of the benefits of a bandsaw is its ability to cut multiple copies of a particular shape by stacking workpieces together and cutting them as one. Before making stacked cuts, ensure that both the table and the blade are properly adjusted to 90°; otherwise, any error will be compounded.

To complete a stacked cut:

1. Align your pieces from top-to-bottom to ensure that each piece has adequate scrap to provide a clean, unhampered cut.
2. Secure all the pieces together in a manner that will not interfere with the cutting. For wood, hot glue on the edges works well, as do brad nails through the waste portion. (Be careful not to cut into the brads or you may break the blade!)
3. On the face of the top piece, mark the shape you intend to cut.
4. Make relief cuts perpendicular to the outline of your intended shape in areas where changes in blade direction could cause the blade to bind.
5. Cut the stack of pieces as though you were cutting a single piece. Follow your layout line with the blade kerf on the waste side of your line as shown in **Figure 36**.

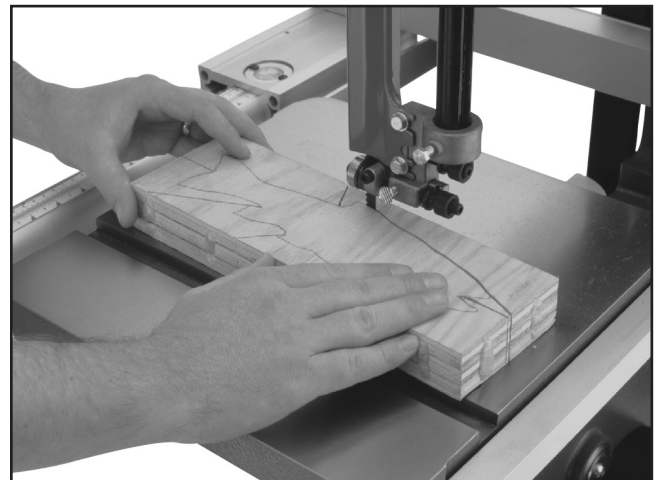

Figure 36. Typical stacked cut.



Blade Selection (Wood Cutting)

Selecting the right blade for the cut requires a knowledge of various blade characteristics.

Blade Length

Measured by the circumference, blade lengths are usually unique to the brand of your bandsaw and the distance between wheels. The Model G0621 uses 108" long blades. Refer to **Page 36** for blade replacements.

Blade Width

Measured from the back of the blade to the tip of the blade tooth (the widest point), blade width is often the first consideration given to blade selection. Blade width dictates the largest and smallest curve that can be cut, as well as how accurately it can cut a straight line.

The Model G0621 uses blades from 1/8" to 1" in width. Always pick the size of blade that best suits your application.

- **Curve Cutting:** Use the chart in **Figure 35** to determine the correct blade for curve cutting. Determine the smallest radius curve that will be cut on your workpiece and use the corresponding blade width.
- **Straight Cutting:** Use the largest width blade that you own. Narrow blades can cut tight curves (a small radius) but are not very good at cutting straight lines because they naturally wander (blade lead). Large blades excel at cutting straight lines and are less prone to wander.

Tooth Style

When selecting blades, another option to consider is the shape, gullet size, teeth set and teeth angle—otherwise known as “Tooth Style.”

Figure 37 illustrates the three main categories of tooth style:

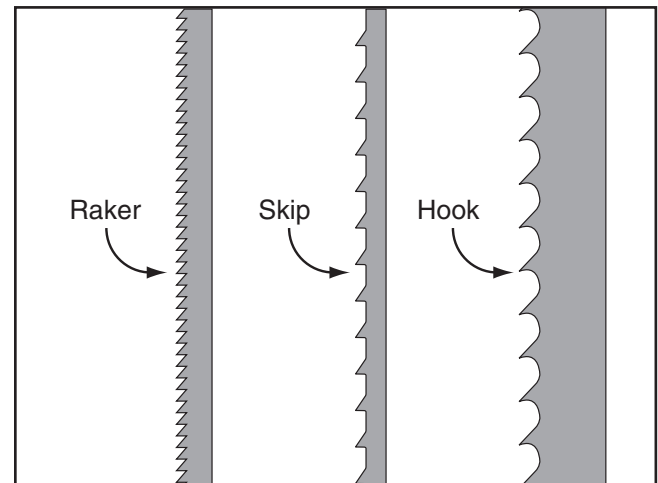

Figure 37. Raker, Skip & Hook tooth styles.

- **Raker:** This style is considered to be the standard because the tooth size and shape are the same as the tooth gullet. The teeth on raker blades usually are very numerous, have no angle, and produce cuts by scraping the material; these characteristics result in very smooth cuts, but do not cut fast and generate more heat than other types while cutting.
- **Skip:** This style is similar to a raker blade that is missing every other tooth. Because of the design, skip toothed blades have a much larger gullet than raker blades, and therefore, cut faster and generate less heat. However, these blades also leave a rougher cut than raker blades.
- **Hook:** The teeth on this style have a positive angle (downward) which makes them dig into the material, and the gullets are usually rounded for easier waste removal. These blades are excellent for the tough demands of resawing and ripping thick material.



Tooth Pitch

Usually measured as TPI (teeth per inch), tooth pitch determines the size/number of the teeth. More teeth per inch (fine pitch) will cut slower, but smoother; while fewer teeth per inch (coarse pitch) will cut rougher, but faster. As a general rule, choose blades that will have at least three teeth in the material at all times. Use fine pitched blades on harder woods and coarse pitched blades on softer woods.

Blade Care

A bandsaw blade is a delicate piece of steel that is subjected to tremendous strain. You can obtain longer use from a bandsaw blade if you give it fair treatment and always use the appropriate feed rate for your operation.

Be sure to select blades with the proper width, style, and pitch for each application. The wrong choice of blades will often produce unnecessary heat which will shorten the life of your blade.

A clean blade will perform much better than a dirty blade. Dirty or gummed up blades pass through the cutting material with much more resistance than clean blades. This extra resistance also causes unnecessary heat. Grizzly sells resin/pitch dissolving cleaners that are excellent for cleaning dirty blades.

Blade Breakage

Many conditions may cause a bandsaw blade to break. Blade breakage is unavoidable, in some cases, since it is the natural result of the peculiar stresses that bandsaw blades must endure. Blade breakage is also due to avoidable circumstances. Avoidable breakage is most often the result of poor care or judgement on the part of the operator when mounting or adjusting the blade or support guides.

The most common causes of blade breakage are:

- Faulty alignment/adjustment of the guides.
- Forcing or twisting a wide blade around a short radius.
- Feeding the workpiece too fast.
- Dull teeth or damaged tooth sufficient set.
- Overtensioned blade.
- Top blade guide assembly set too high above the workpiece.
- Using a blade with a lumpy or improperly finished braze or weld.
- Continuously running the bandsaw when not in use.
- Leaving blade tensioned when not in use.
- Using the wrong TPI for the workpiece thickness. (The general rule of thumb is 3 teeth in the workpiece at all times.)



Blade Selection (Metal Cutting)

Selecting the right blade for the job depends on a variety of factors, such as the type of material being cut, hardness of the material, material shape machine capability, and operator technique.

The chart below is a basic starting point for choosing blade type based on teeth per inch (TPI) for variable tooth pitch blades and for standard raker type bi-metal blades/HSS blades. However, for exact specifications of bandsaw blades, contact the blade manufacturer.

To select the correct blade TPI:

1. Measure the material thickness. This measurement is the length of cut taken from where the tooth enters the workpiece, sweeps through, and exits the workpiece.

2. Refer to the "Material Width/Diameter" row of the blade selection chart in **Figure 38** and read across to find the workpiece thickness you need to cut.
3. Refer to the "Material Shapes" row and find the shape and material to be cut.
4. In the applicable row, read across to the right and find the box where the row and column intersect. Listed in the box is the minimum TPI recommended for the variable tooth pitch blades.
5. The "Cutting Speed Rate Recommendation" section of the charts offers guidelines for various metals, given in feet per minute (speed FPM) and meters per minute in parenthesis.

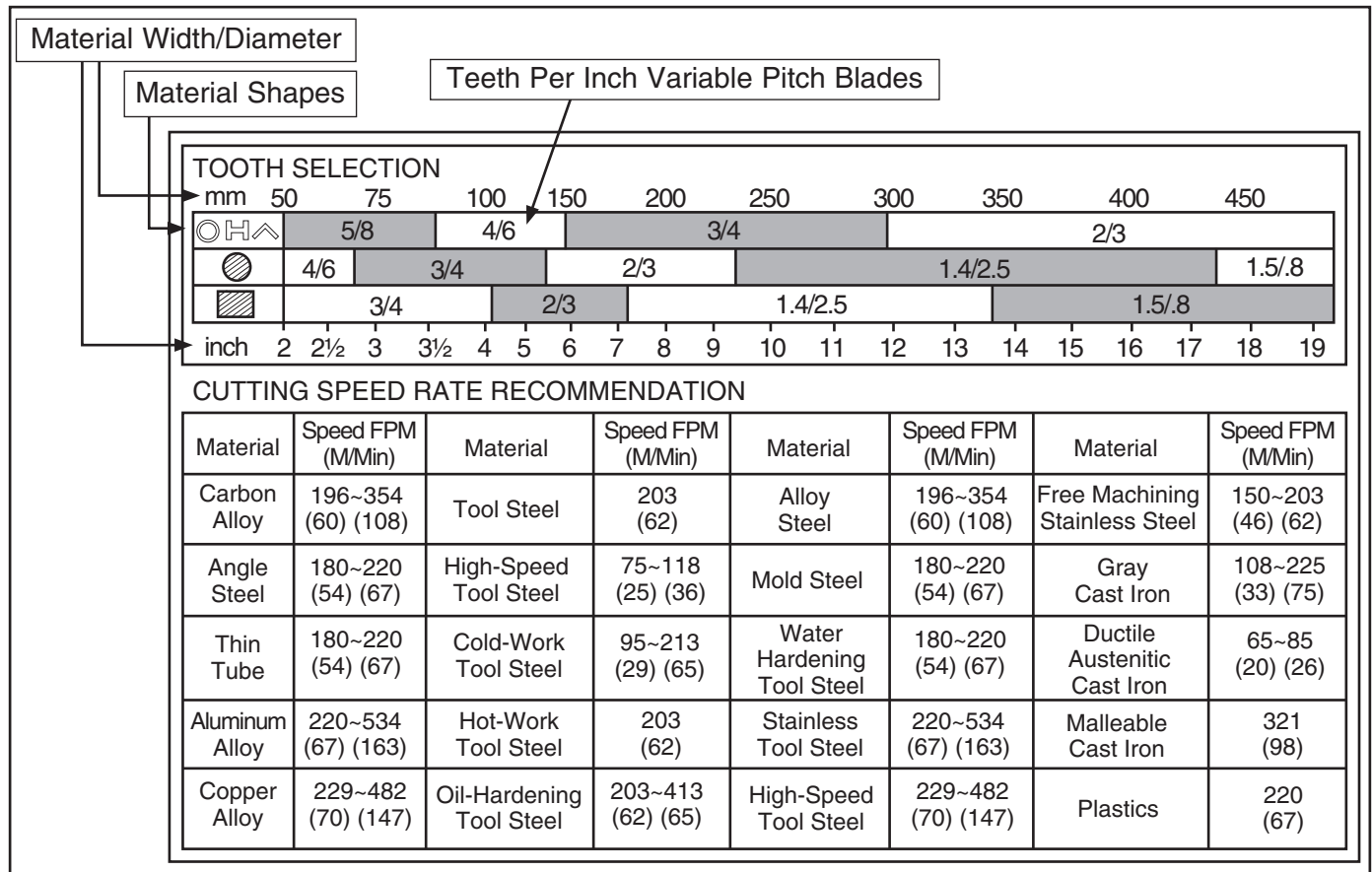
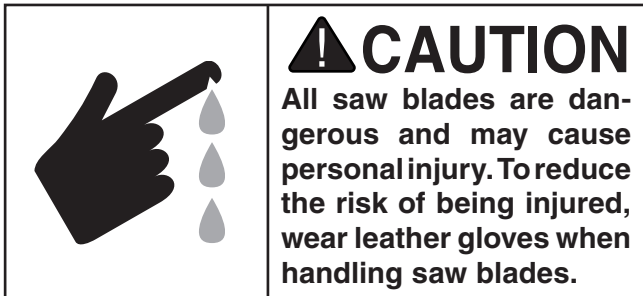
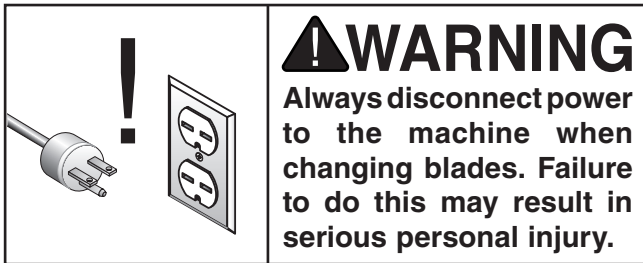

Figure 38. Blade selection and speed chart.



Blade Changes



To replace the blade:

1. DISCONNECT BANDSAW FROM POWER!
2. Release the tension lever.
3. Remove the table insert and the table pin. Adjust the upper and lower guide blocks away from the blade.
4. Open the upper and lower wheel covers and slide the blade off both wheels.
5. Rotate the blade 90° and slide it through the slot in the table.
6. Slide the blade through the table slot, ensuring that the teeth are pointing down toward the table. *If the teeth will not point downward in any orientation, the blade is inside-out. Put on heavy gloves, remove the blade, and twist it rightside-out.*
7. Slip the blade through the guides, and mount it over the upper and lower wheels.
8. Apply tension.

9. Turn the tension knob until proper blade tension has been reached according to the blade thickness scale shown in **Figure 39**.



Figure 39. Tensioner adjustment.

10. Check and adjust the tracking (**Page 18**).
11. Adjust the upper/lower guide blocks and the support bearings (**Pages 20 and 22**).
12. Close the wheel covers.
13. Replace the table insert and table pin, being sure not to use excessive force when inserting the table pin.



Scale Calibration

You may need to recalibrate the fence scale after changing or adjusting the blade, or if the scale is not producing accurate cuts. Recalibrate the fence scale by adjusting the hairline indicator on the fence and testing your adjustment by cutting a piece of scrap wood.

To calibrate the scale:

1. Set the fence anywhere along the scale and locate a piece of scrap wood with at least one straight edge. *Joint the edge with a jointer (if needed) to make the edge straight.*
2. Hold the straight edge of the workpiece firmly against the fence, and feed the workpiece through the saw blade with a push stick.
3. Measure the width of the cut workpiece. The width of the workpiece should match the reading on the fence scale.

4. If the reading on the scale is not the same as the width of the cut workpiece, loosen the screws on the magnifying window (**Figure 40**) and adjust it to match the width of the cut workpiece.
5. Tighten the screws; the scale is now correctly calibrated.

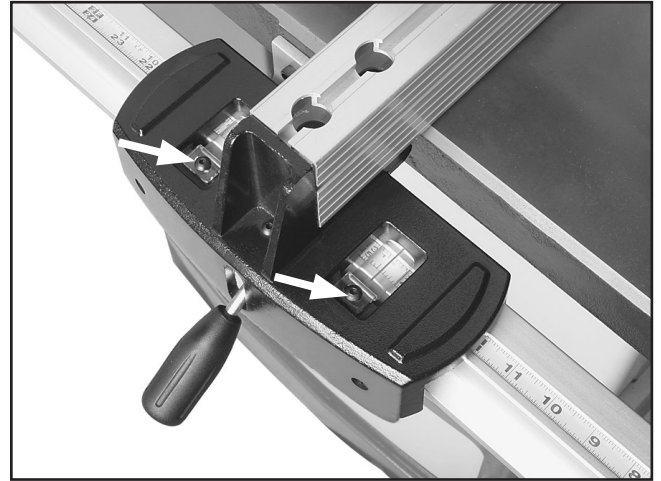

Figure 40. Scale calibration screws.



SECTION 5: ACCESSORIES

G7315Z—Super Heavy-Duty Mobile Base

Mobilize your machine with this popular patented mobile base. The unique outrigger-type supports increase stability and lower machine height. This heavy duty mobile base is rated for up to a 1300 lb. capacity.

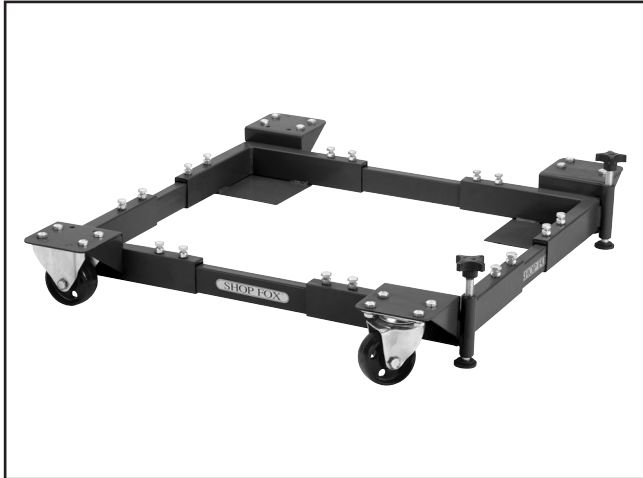

Figure 41. G7315Z SHOP FOX® Mobile Base.

G1928—Bandsaw Handbook

This is the bandsaw bible. Covers step-by-step instructions for basic/advanced cutting techniques. Also includes advanced maintenance, service and troubleshooting procedures, as well as information on bandsaw history/design and blade metallurgy. 320 pages.

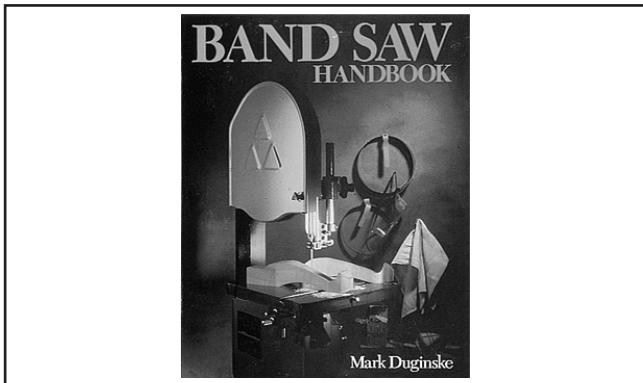

Figure 42. Bandsaw handbook.

Grizzly Bandsaw Blades

MODEL	LENGTH	WIDTH	TPI	GAUGE
H9736	108 $\frac{1}{8}$ "	1"	3-4 VP	0.032
H9737	108 $\frac{1}{8}$ "	1"	4-6 VP	0.032
H9738	108 $\frac{1}{8}$ "	1"	5-8 VP	0.032
H9739	108 $\frac{1}{8}$ "	1"	6-10 VP	0.032
H9740	108 $\frac{1}{8}$ "	1"	8-12 VP	0.032
H9741	108 $\frac{1}{8}$ "	1"	10-14 VP	0.032
H9956	108"	$\frac{1}{8}$ "	14 Raker	0.025
H9957	108"	$\frac{1}{8}$ "	18 Raker	0.025
H9958	108"	$\frac{3}{16}$ "	4 Skip	0.025
H9959	108"	$\frac{3}{16}$ "	10 Raker	0.025
H9960	108"	$\frac{3}{16}$ "	14 Raker	0.025
H9961	108"	$\frac{1}{4}$ "	4 Hook	0.025
H9962	108"	$\frac{1}{4}$ "	6 Hook	0.025
H9963	108"	$\frac{1}{4}$ "	10 Raker	0.025
H9964	108"	$\frac{1}{4}$ "	14 Raker	0.025
H9965	108"	$\frac{1}{4}$ "	18 Raker	0.025
H9966	108"	$\frac{3}{8}$ "	4 Hook	0.025
H9967	108"	$\frac{3}{8}$ "	6 Hook	0.025
H9968	108"	$\frac{3}{8}$ "	10 Raker	0.025
H9969	108"	$\frac{3}{8}$ "	14 Raker	0.025
H9970	108"	$\frac{1}{2}$ "	3 Hook	0.025
H9971	108"	$\frac{1}{2}$ "	4 Hook	0.025
H9972	108"	$\frac{1}{2}$ "	6 Hook	0.025
H9973	108"	$\frac{1}{2}$ "	10 Raker	0.025
H9974	108"	$\frac{1}{2}$ "	14 Raker	0.025
H9975	108"	$\frac{3}{4}$ "	3 Hook	0.032
H9976	108"	$\frac{3}{4}$ "	6 Hook	0.032
H9977	108"	$\frac{3}{4}$ "	10 Raker	0.032
H9978	108"	1"	2 Hook	0.035
H9979	108"	1"	6 Hook	0.035

Call 1-800-523-4777 To Order



SECTION 6: MAINTENANCE

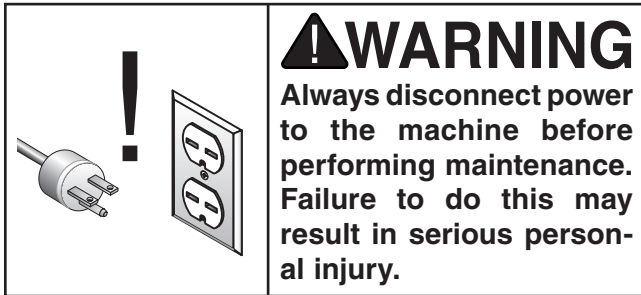

Schedule

For optimum performance from your machine, follow this maintenance schedule:

Daily

- Check/correct loose mounting bolts.
- Check/correct damaged saw blade.
- Check/correct worn or damaged wires.
- Correct any other unsafe condition.

Monthly

- Check for V-belt tension, damage, or wear.
- Remove blade and thoroughly clean all built-up sawdust from the rubber tires on the wheels.
- Clean/vacuum dust buildup from inside cabinet and off motor.

Cleaning

Vacuum excess wood chips and sawdust, and wipe off the remaining dust with a dry cloth. If resin has built up, use a resin dissolving cleaner to remove it.

Once a month, remove the blade and thoroughly clean all built-up sawdust from the rubber tires on the wheels.



Lubricating

Protect the unpainted cast iron surfaces on the table by wiping the table clean after every use—this ensures moisture from wood dust does not remain on bare metal surfaces. Keep tables rust-free with regular applications of general lubricants such as G96® Gun Treatment, SLIPIT®, or Boeshield® T-9.

If the table becomes difficult to tilt, remove it and lubricate the trunnions and the slides in the trunnion base with a general lubricant.

Redressing Rubber Tires

As the bandsaw ages, the rubber tires on the wheels may need to be redressed if they harden or glaze over. Redressing the rubber tires improves blade tracking and reduces vibration/blade lead.

If the rubber tires become too worn, then blade tracking will become extremely difficult. At that point, redressing will no longer be effective and the rubber tires must be replaced.

To redress the rubber tires:

1. DISCONNECT BANDSAW FROM POWER!
2. Put on heavy leather gloves.
3. Remove the blade.
4. Clean any built-up sawdust from the rubber tires.
5. Hold 100 grit sandpaper against the rubber tire and rotate the wheel by hand. Only redress the rubber enough to expose a fresh rubber surface.

SECTION 7: SERVICE

Review the troubleshooting and procedures in this section to fix or adjust your machine if a problem develops. If you need replacement parts or you are unsure of your repair skills, then feel free to call our Technical Support at (570) 546-9663.

Troubleshooting

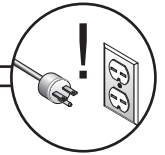

Motor & Electrical

Symptom	Possible Cause	Possible Solution
Machine does not start or a breaker trips.	<ol style="list-style-type: none"> 1. OFF button has not been reset. 2. Plug/receptacle is at fault or wired incorrectly. 3. Motor connection wired incorrectly. 4. Wall fuse/circuit breaker is blown/tripped. 5. Power supply switched OFF or is at fault. 6. Wiring is open/has high resistance. 7. Motor ON button or ON/OFF switch is at fault. 8. Inverter/Controller box is at fault. 9. Motor is at fault. 	<ol style="list-style-type: none"> 1. Lift paddle and press OFF button down completely until it clicks. 2. Test for good contacts; correct the wiring. 3. Correct motor wiring connections. 4. Ensure circuit size is suitable for this machine; replace weak breaker. 5. Ensure power supply is switch on; ensure power supply has the correct voltage. 6. Check for broken wires or disconnected/corroded connections, and repair/replace as necessary. 7. Replace faulty ON button or ON/OFF switch. 8. Inspect inverter/controller box; replace if faulty. 9. Test/repair/replace.
Machine stalls or is underpowered.	<ol style="list-style-type: none"> 1. Feed rate/cutting speed too fast for task. 2. Machine is undersized for the task. 3. Blade is slipping on wheels. 4. Motor connection is wired incorrectly. 5. Plug/receptacle is at fault. 6. Pulley/sprocket slipping on shaft. 7. Motor is at fault. 	<ol style="list-style-type: none"> 1. Decrease feed rate/cutting speed. 2. Use sharp blade with lower TPI; reduce the feed rate/depth of cut. 3. Adjust blade tracking and tension to factory specifications. 4. Correct motor wiring connections. 5. Test for good contacts; correct the wiring. 6. Replace loose pulley/shaft. 7. Test/repair/replace.
Machine has vibration or noisy operation.	<ol style="list-style-type: none"> 1. Motor or component is loose. 2. Blade weld is at fault or teeth are broken. 3. Blade is at fault. 4. V-belt worn or loose. 5. Pulley is loose. 6. Motor mount loose/broken. 7. Machine is incorrectly mounted or sits unevenly. 8. Motor fan is rubbing on fan cover. 9. Motor bearings are at fault. 	<ol style="list-style-type: none"> 1. Inspect/replace stripped or damaged bolts/nuts, and re-tighten with thread locking fluid. 2. Replace blade. 3. Replace warped, bent, or twisted blade; sharpen dull blade. 4. Inspect/replace belt. 5. Realign/replace shaft, pulley, setscrew, and key as required. 6. Tighten/replace. 7. Tighten/replace anchor studs in floor; relocate/shim machine. 8. Replace dented fan cover; replace loose/damaged fan. 9. Test by rotating shaft; rotational grinding/loose shaft requires bearing replacement.



Cutting Operations

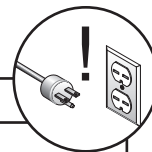

Symptom	Possible Cause	Possible Solution
Machine slows when operating.	<ol style="list-style-type: none"> 1. Feeding workpiece too fast. 2. Blade is dull. 	<ol style="list-style-type: none"> 1. Reduce feed rate. 2. Replace blade (Page 34).
Ticking sound when the saw is running.	<ol style="list-style-type: none"> 1. Blade weld contacting guide/support bearings (a light tick is normal). 2. Blade weld may be failing. 	<ol style="list-style-type: none"> 1. Use file or stone to smooth and round the back of the blade; slightly loosen the blade guides. 2. Inspect and replace blade if necessary (Page 34).
Blade contacting table insert.	<ol style="list-style-type: none"> 1. Insert installed upside down or backwards. 2. Table improperly mounted or aligned. 	<ol style="list-style-type: none"> 1. Re-install insert a different way. 2. Align table (Page 24).
Vibration when cutting.	<ol style="list-style-type: none"> 1. Loose or damaged blade. 2. Sawdust buildup on wheels. 	<ol style="list-style-type: none"> 1. Tighten or replace blade (Page 34). 2. Clean all sawdust from rubber tires on wheels.
Burn marks on the edge of the cut.	<ol style="list-style-type: none"> 1. Too much side pressure when feeding workpiece; blade is binding. 2. Blade too wide for size of radius being cut. 	<ol style="list-style-type: none"> 1. Feed workpiece straight into the blade. See Basic Cutting Tips on Page 26. 2. Install a smaller width blade/increase blade tension. See Page 34 or 20.
Rough or poor quality cuts.	<ol style="list-style-type: none"> 1. Feeding workpiece too fast. 2. Blade guides adjusted incorrectly. 	<ol style="list-style-type: none"> 1. Reduce feed rate. 2. Re-adjust all blade guides and support bearings.
Sawdust buildup inside cabinet.	<ol style="list-style-type: none"> 1. Clogged dust port. 2. Low CFM (airflow) from the shop vacuum. 	<ol style="list-style-type: none"> 1. Clean out dust port. 2. Three options: —Check dust hoses for leaks or clogs. —Connect saw to a more powerful shop vacuum.
Blade wanders or doesn't cut straight.	<ol style="list-style-type: none"> 1. Blade lead. 2. Sawdust buildup on wheels. 	<ol style="list-style-type: none"> 1. Refer to Blade Lead on Page 42. 2. Clean all sawdust from rubber tires on wheels.
Cuts are not square (vertically).	<ol style="list-style-type: none"> 1. Table tilt is not adjusted to 0° or positive stop has moved out of adjustment. 2. Table tilt scale pointer is not calibrated. 3. Table is not square to the blade. 	<ol style="list-style-type: none"> 1. Adjust table tilt to 0°; readjust positive stop if necessary (Page 23). 2. Calibrate table tilt scale pointer to 0° (Page 23). 3. Shim table (Page 42).

Miscellaneous

Symptom	Possible Cause	Possible Solution
Blade tension scale is grossly inaccurate.	<ol style="list-style-type: none"> 1. The spring in the blade tension mechanism has lost its "spring." This is caused by not releasing the blade tension when not in use or frequently over-tensioning the bandsaw. 	<ol style="list-style-type: none"> 1. Replace spring in the blade tension mechanism, then take better care of the bandsaw by releasing tension when not in use and not over-tensioning the blade.
Wheel is noisy.	<ol style="list-style-type: none"> 1. Wheel bearing is worn out. 2. Belt is too tight (lower wheel). 	<ol style="list-style-type: none"> 1. Replace the wheel bearing. 2. Check/loosen the belt tension (Page 40).
Blade does not track consistently, correctly, or at all.	<ol style="list-style-type: none"> 1. Wheels are not coplanar or aligned with each other. 2. Rubber tires on wheels are worn out. 	<ol style="list-style-type: none"> 1. Adjust wheels to be coplanar/aligned with each other (Page 43). 2. Redress the rubber tires on the wheels (Page 37); replace the rubber tires on the wheels.



Servicing V-Belts

To ensure optimum power transfer from the motor to the blade, the V-belts must be in good condition and operate under proper tension. Check belt tension at least every 3 months—more often if the bandsaw is used daily. V-belts stretch with use and must be periodically re-tensioned.

Replace the V-belts if they are cracked, frayed, or excessively worn.

Accessing V-Belts

1. DISCONNECT BANDSAW FROM POWER!
2. Open the lower wheel cover.
3. Remove the bandsaw blade.
4. Remove the lower wheel by removing the hex bolt at the center of the wheel, then sliding the wheel off the shaft. (The hex nut has left handed threads, so you must turn it clockwise to loosen it.)
5. Take off the pulley cover plate by removing the six Phillips head screws. You now have access to the V-belts for inspection or service (see **Figure 43**).

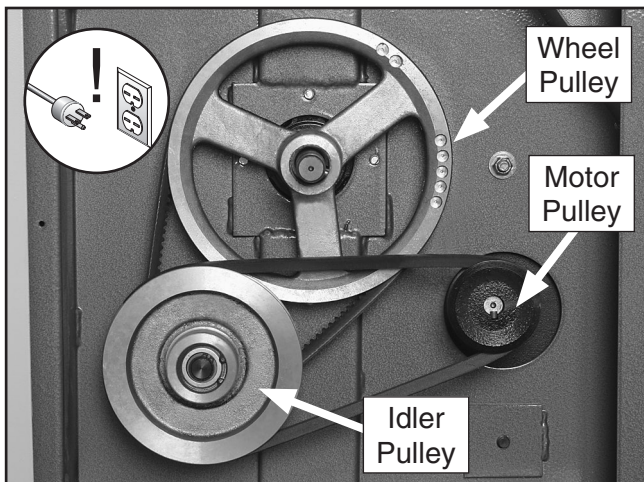

Figure 43. Pulleys and V-belts.

Checking V-Belts

1. Follow all previous instructions for **Accessing V-Belts**.
2. Push the center of each V-belt as illustrated in **Figure 44**, using moderate force. When tensioned correctly, the deflection should be about 1/4".

—If the deflection is more than 1/4", then tension that V-belt (see **Page 41**) before doing **Step 4**.

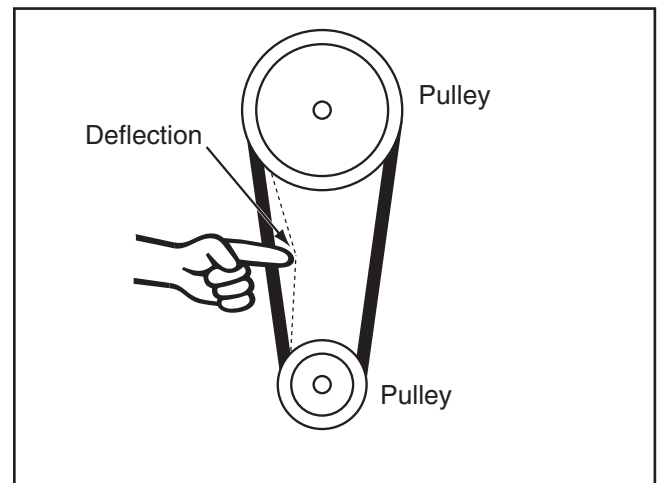

Figure 44. Belt deflection.

3. Use a flashlight to inspect the belt.
—If a V-belt is cracked, frayed, or glazed, replace it as soon as convenient.
4. Replace the pulley cover, lower wheel, and blade; then close the lower wheel cover.



Tensioning/Replacing V-Belts

1. Follow all previous instructions for **Accessing V-Belts**.
2. Loosen the motor mount bolts shown in **Figure 45**.

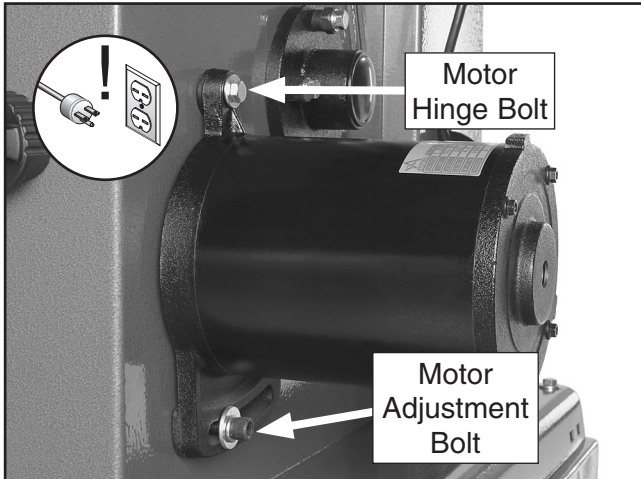

Figure 45. Motor mount bolts.

3. Loosen the idler pulley mounting nut behind the cap shown in **Figure 46**.

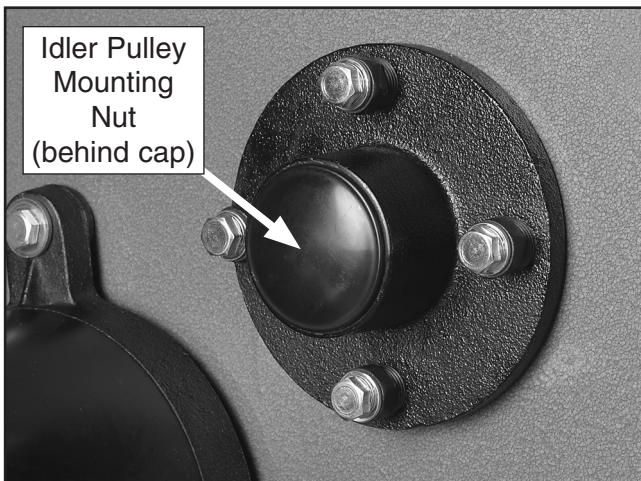

Figure 46. Location of idler pulley mounting nut.

—If you only need to retension the V-belts, skip to **Step 6**.

—If you need to replace the V-belts, continue with **Step 4**.

4. Pivot the motor and slide the idler pulley to loosen the V-belts.
5. Remove old V-belts and install the new V-belts.
6. Slide the idler pulley down to tighten the lower wheel V-belt, hold pressure on the idler pulley, then tighten the mounting nut.
7. Check the wheel pulley V-belt for correct tension. Retension if necessary before continuing.
8. Pivot the motor to tighten the motor V-belt, hold pressure on the motor, then tighten the motor adjustment bolt.
9. Check the motor V-belt for correct tension. Retension if necessary before continuing.
10. When the belt tension is correct, tighten the motor hinge bolt.
11. Replace the pulley cover, lower wheel, and blade; then close the lower wheel cover.



Shimming Table

To ensure accuracy when cutting stacked workpieces, the table should be 90° to the back of the blade as shown in **Figure 47**. If the table is not perpendicular to the back of the blade, the table needs to be shimmed.

Shims can be made of any durable object that can be sandwiched between the table and the trunnions. We recommend using shim washers or shim stock because of the wide range of available thicknesses. These items can be purchased at your local hardware store.

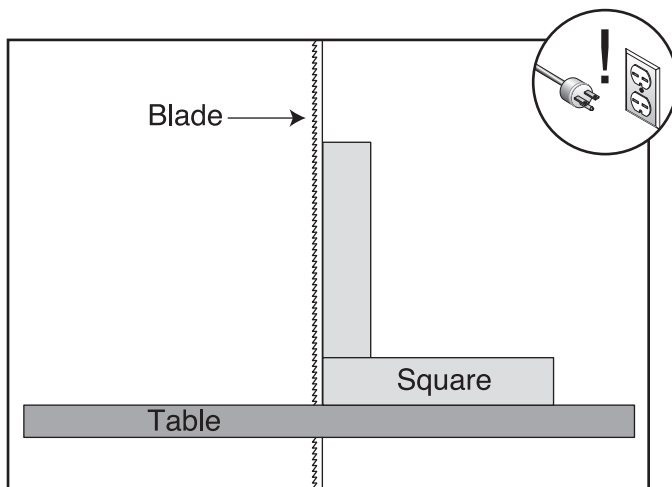

Figure 47. Squaring table to blade back.

To shim the table:

1. Make sure that the blade is tracking properly and that it is correctly tensioned.
2. DISCONNECT BANDSAW FROM POWER!
3. Loosen the trunnion bolts that secure the trunnions to the table.
4. Place shim stock between the table and the two trunnions to shim the table in the desired direction.

Note: Another way to shim the table is to add washers between the table and the trunnion.

5. Follow the **Aligning Table** instructions on **Page 24** to complete this procedure.

Blade Lead

"Blade Lead" means that the blade does not cut straight when using the fence or miter gauge (see **Figure 48**). This is a common condition with all bandsaws. Worn or damaged blades may cause lead and replacing them will fix the problem. Still, if your bandsaw is setup correctly and lead occurs, compensate for it by skewing the fence.

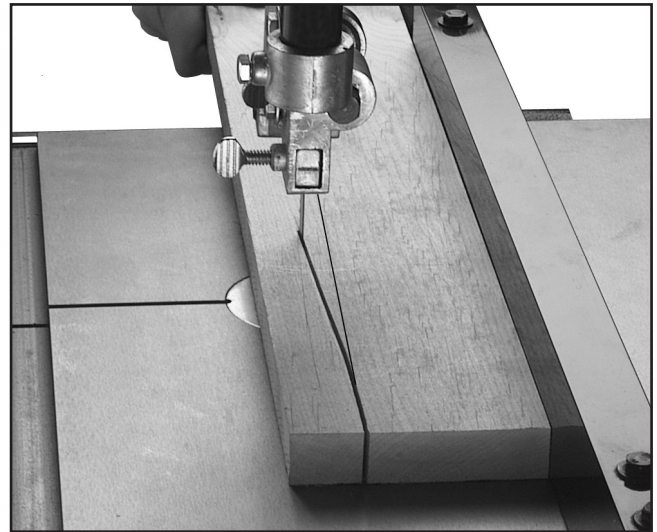

Figure 48. Blade leading away from line of cut.

To correct blade lead, do the following steps and make a test cut before skewing the fence:

1. Ensure that you have proper blade tension (refer to **Page 20**).
2. Ensure that the blade guides are adjusted correctly (refer to **Pages 20 & 22**).
3. Ensure that the miter slot or fence is parallel to the blade (refer to **Page 24**).

To skew your fence:

1. Cut a piece of scrap wood approximately $\frac{3}{4}$ " thick x 3" wide x 17" long. On a wide face of the board, draw a straight line parallel to the long edge.
2. Slide the fence out of the way and cut free-hand along the line. Stop at the halfway point. Turn the bandsaw **OFF** and wait for the blade to stop.



3. Clamp the board to the bandsaw table without moving it. Now slide the fence over to the board so it barely touches one end of the board.
4. Loosen the two cap screws that mount the front rail to the table.
5. Place shims between the front rail and the table as necessary to make the fence parallel to the edge of the scrap piece.

Note: *Shim stock works well for this, but small pieces of paper can also work in a pinch.*

To compensate for lead when making straight crosscuts with the miter gauge, you will need to shift the table:

1. Set the miter gauge to 90° and verify that the gauge body is square to the miter bar, using a 90° square.
2. On a scrap piece of wood, mark a line that is perpendicular to the front edge of the workpiece.
3. Starting where the line begins, cut the board by pushing it through the blade with the miter gauge.
4. Loosen the table mounting bolts, and shift the table to compensate for the blade lead.
5. Repeat **Steps 1 & 2** until the blade cuts straight when wood is pushed through with the miter gauge.

NOTICE

If the table is shifted, the fence will be affected since it is attached.

NOTICE

Lead adjustments will change when new blades are mounted on the saw.

Wheel Alignment

Wheel alignment, or "Coplanar Tracking," is one of the easiest ways to ensure you get optimal performance from your bandsaw. When wheels are aligned, or coplanar, the bandsaw cuts straighter. Vibration, heat, and blade wear are also considerably decreased because the blade is automatically balanced on the wheel.

Verifying Upper/Lower Wheels are Coplanar

1. DISCONNECT BANDSAW FROM POWER!
2. With the blade on and properly tensioned, hold a straightedge close to the center of both wheels. Make sure the straightedge fully extends across the wheels as shown in **Figure 49**.

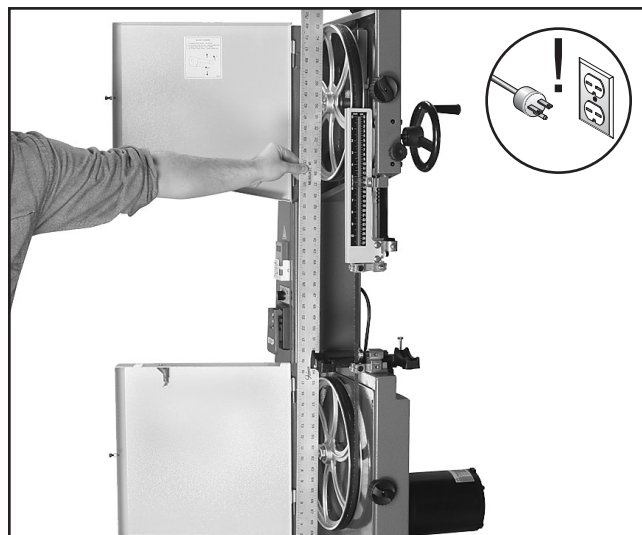

Figure 49. Checking wheel alignment with a straightedge.

—If the wheels are coplanar, the straightedge will touch the top and bottom of the outside rims on each wheel.

—If the wheels are not coplanar, place the straightedge on the lower wheel first (ensuring that it touches both the top and bottom rim), then adjust the tracking knob to see how the upper wheel lines up with the straightedge.



—If the straightedge does not touch both wheels evenly, the upper wheel needs to be shimmed or the lower wheel needs to be adjusted.

Shimming Upper Wheel

1. DISCONNECT BANDSAW FROM POWER!
2. Adjust the tracking knob so the top wheel is parallel with the bottom wheel.
3. With the straightedge touching both points of the wheel that does not need to be adjusted, measure the distance away from the incorrect wheel with a fine ruler (see **Figure 50**). The distance measured with the ruler is the distance the wheel must be corrected.



Figure 50. Measuring wheel difference.

4. Remove the blade from the saw, then remove the wheel that needs to be shimmed.
5. Determine how many shim washers you need and place them on the wheel shaft.
6. Replace the wheel, the original washers, and the securing nut.
7. Tighten the blade, then check the wheels. (Coplanar wheels may pull out of alignment when the blade is tightened.)
8. When the wheels are coplanar, place a mark on each wheel where you held the straightedge. This assures repeated accuracy every time you adjust your wheels.

Note: When wheels are properly coplanar, the blade may not be centered on the crown of the wheel, but it will be balanced. See **Figure 51** to better understand coplanarity.

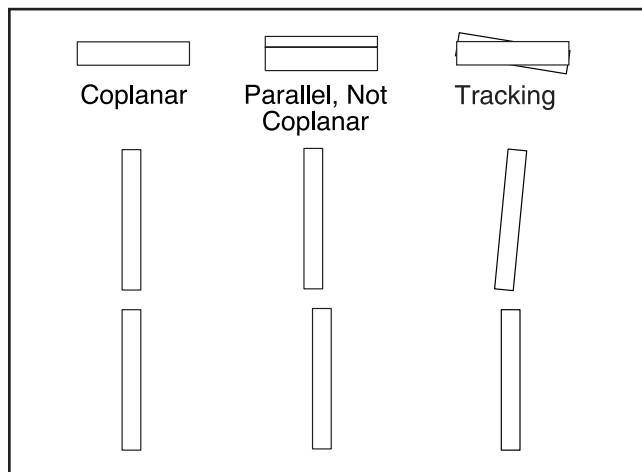

Figure 51. Coplanar diagram.

Adjusting Lower Wheel

Only do this procedure if you cannot make the wheels coplanar with the tracking knob or by shimming the upper wheel. Make sure the upper wheel is adjusted as close as possible to being coplanar with the lower wheel before beginning. Do this procedure with the blade fully tensioned.

To adjust the lower wheel:

1. DISCONNECT BANDSAW FROM POWER!
2. Loosen the four hex bolts on the lower wheel adjustment hub (**Figure 52**). These secure the wheel adjustment sleeves.

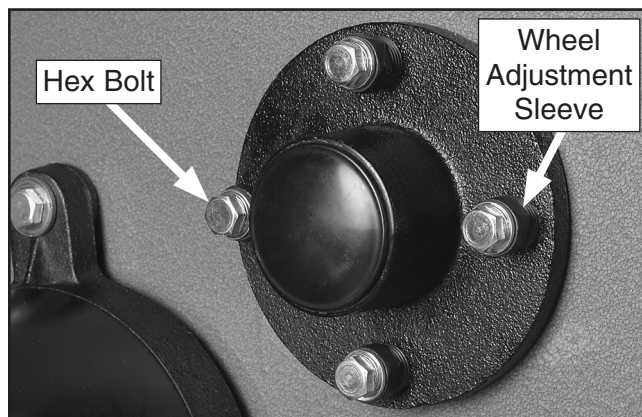

Figure 52. Wheel adjustment hub.

3. Rotate the wheel adjustment sleeves to move the lower wheel as necessary to make it coplanar with the upper wheel.
4. Tighten the hex bolts to secure the wheel adjustment sleeves in position.



SECTION 8: WIRING

These pages are current at the time of printing. However, in the spirit of improvement, we may make changes to the electrical systems of future machines. Study this section carefully. If there are differences between your machine and what is shown in this section, call Technical Support at (570) 546-9663 for assistance BEFORE making any changes to the wiring on your machine.

WARNING

Wiring Safety Instructions

- 1. SHOCK HAZARD.** Working on wiring that is connected to a power source is extremely dangerous. Touching electrified parts will result in personal injury including but not limited to severe burns, electrocution, or death. Disconnect the power from the machine before servicing electrical components!
- 2. QUALIFIED ELECTRICIAN.** Due to the inherent hazards of electricity, only a qualified electrician should perform wiring tasks on this machine. If you are not a qualified electrician, get help from one before attempting any kind of wiring job.
- 3. WIRE CONNECTIONS.** All connections must be tight to prevent wires from loosening during machine operation. Double-check all wires disconnected or connected during any wiring task to ensure tight connections.
- 4. WIRE/COMPONENT DAMAGE.** Damaged wires or components increase the risk of serious personal injury, fire, or machine damage. If you notice that any wires or components are damaged while performing a wiring task, replace those wires or components before completing the task.
- 5. MODIFICATIONS.** Using aftermarket parts or modifying the wiring beyond what is shown in the diagram may lead to unpredictable results, including serious injury or fire.
- 6. MOTOR WIRING.** The motor wiring shown in these diagrams is current at the time of printing, but it may not match your machine. Always use the wiring diagram inside the motor junction box.
- 7. CAPACITORS/INVERTERS.** Some capacitors and power inverters store an electrical charge for up to five minutes after being disconnected from the power source. To avoid being shocked, wait at least this long before working on capacitors.
- 8. CIRCUIT REQUIREMENTS.** You MUST follow the requirements at the beginning of this manual when connecting your machine to a power source.
- 9. EXPERIENCING DIFFICULTIES.** If you are experiencing difficulties understanding the information included in this section, contact our Technical Support at (570) 546-9663.



Electrical Component Wiring

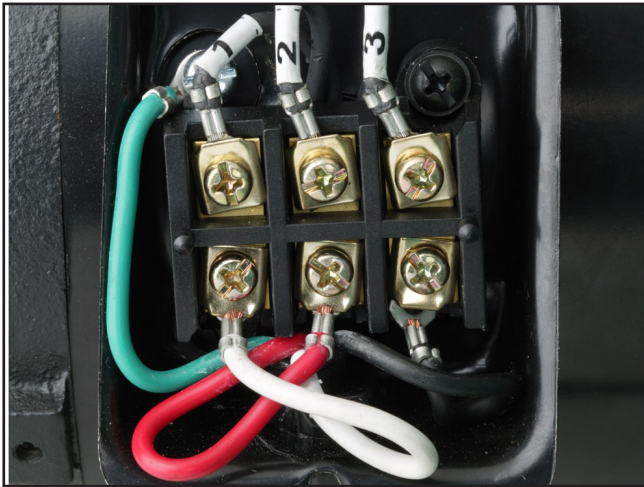

Figure 53. Motor junction box wiring.

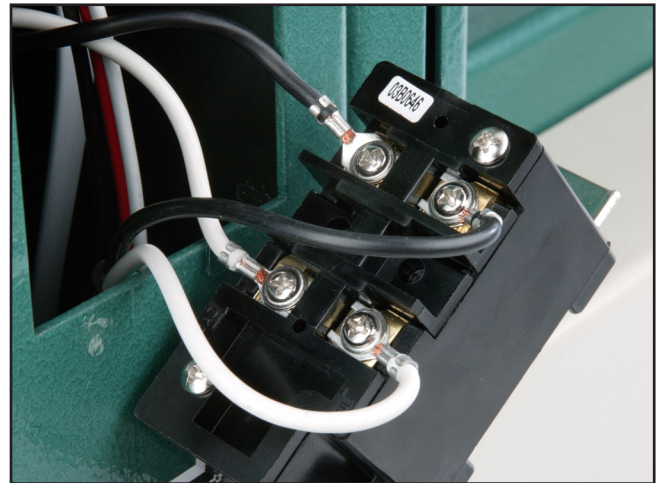

Figure 55. Power switch.



Figure 54. Motor switch.

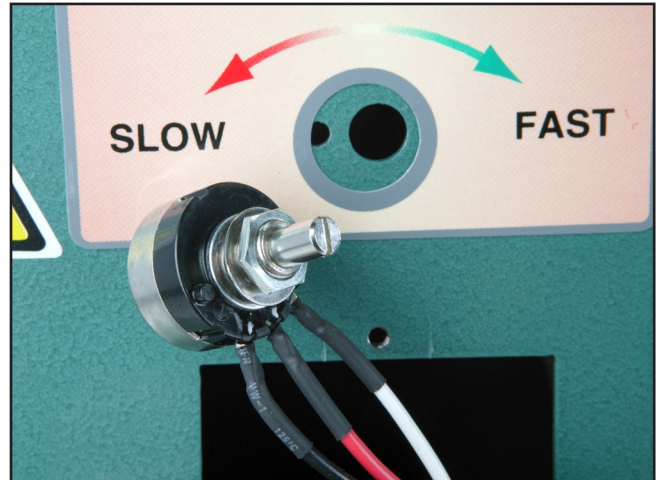

Figure 56. Variable speed dial.

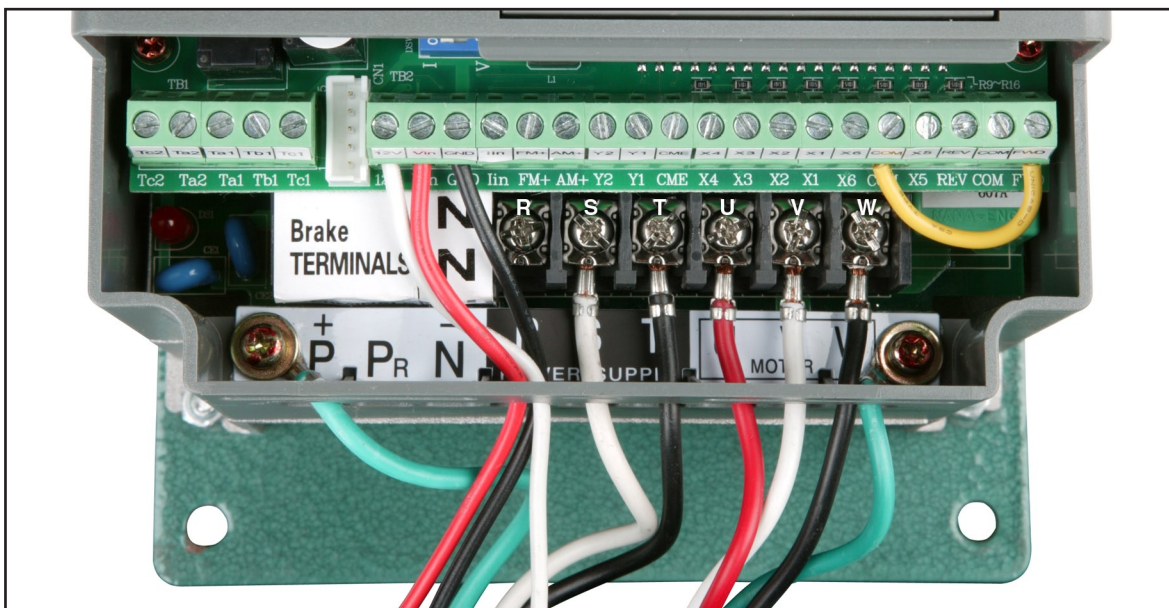
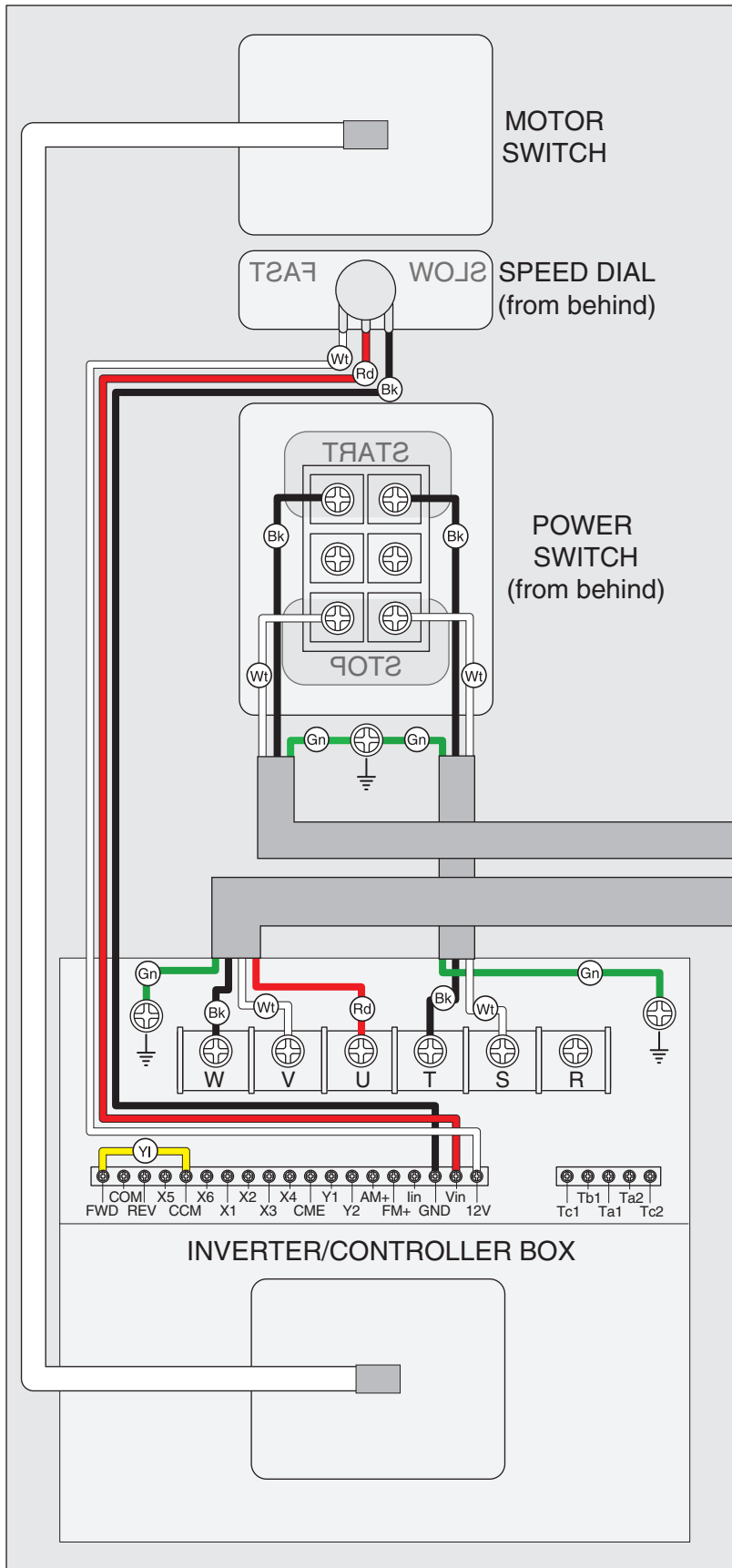

Figure 57. Inverter/controller box terminal blocks.



Wiring Diagram



WARNING!

SHOCK HAZARD!
Disconnect power before working on wiring.

View this wiring diagram in color at www.grizzly.com.



COLOR KEY

BLACK	Bk
WHITE	Wt
GREEN	Gn
RED	Rd
YELLOW	Yl

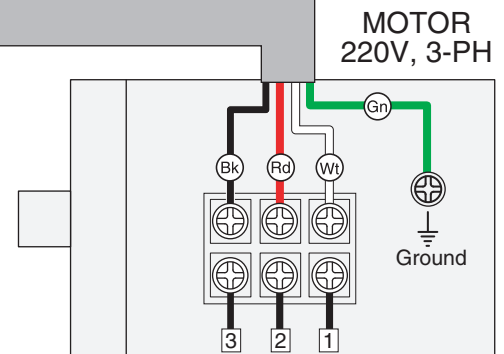
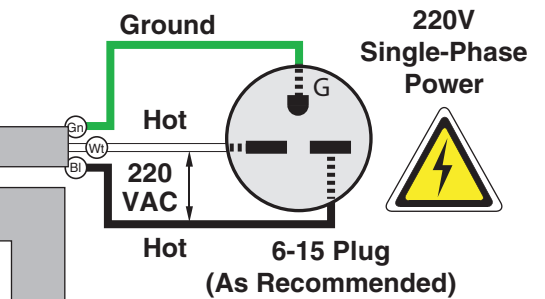

NOTICE

The motor wiring shown here is current at the time of printing; however, always use the diagram on the inside of junction box cover when rewiring your motor.



SECTION 9: PARTS

Main Parts Breakdown

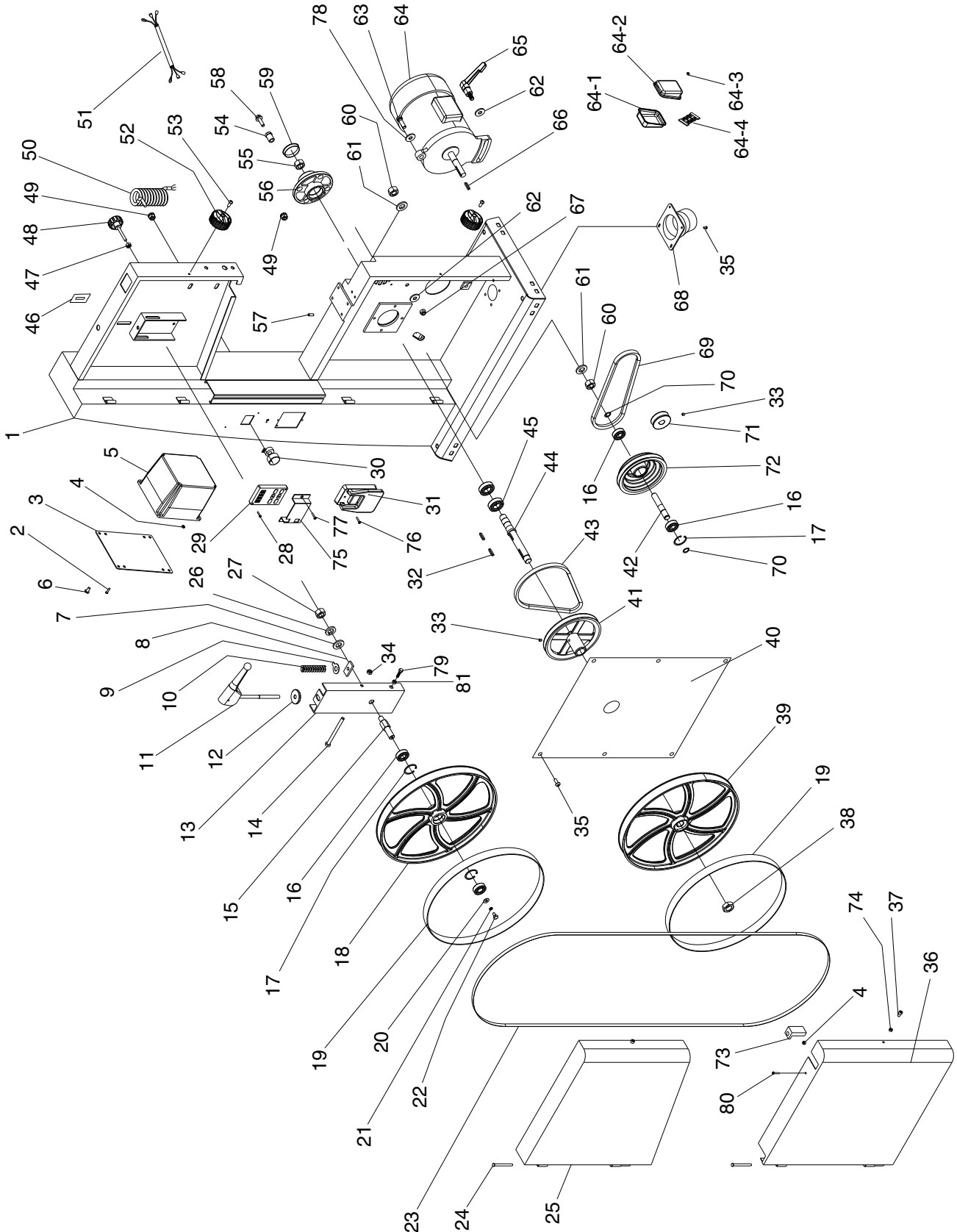

Main Parts List

REF	PART #	DESCRIPTION
1	P0621001	BODY
2	PS08	PHLP HD SCR 10-24 X 3/4
3	P0621003	CONTROLLER COVER PLATE
4	PN07	HEX NUT 10-24
5	P0621005	AC MOTOR CONTROLLER
6	P0621006	PHLP HD SCR 1/4-20 X 1/2
7	PW01	FLAT WASHER 1/2
8	P0621008	TENSION NUT
9	P0621009	BLADE TENSION POINTER
10	P0621010	COMPRESSION SPRING
11	P0621011	BLADE TENSION HANDLE
12	P0621012	SPECIAL WASHER
13	P0621013	UPPER WHEEL BRACKET
14	P0621014	HEX BOLT M8-1.25 x 110
15	P0621015	UPPER WHEEL SHAFT
16	P6202	BALL BEARING 6202ZZ
17	PR21M	INT RETAINING RING 35MM
18	P0621018	UPPER WHEEL
19	P0621019	TIRE
20	PW06	FLAT WASHER 1/4
21	PLW02	LOCK WASHER 1/4
22	PB51	HEX BOLT 1/4-20 X 3/8
23	P0621023	BLADE 0.65"T X 3/8"W X 108"
24	P0621024	HINGE PIN
25	P0621025	UPPER WHEEL COVER
26	PLW07	LOCK WASHER 1/2
27	PN01	HEX NUT 1/2-20
28	P0621028	PHLP HD SCR M3-.5 X 18
29	P0621029	MANIPULATOR
30	P0621030	SPEED DIAL
31	P0621031	SWITCH W/LARGE STOP
32	PK23M	KEY 5 X 5 X 25
33	PSS03	SET SCREW 1/4-20 X 3/8
34	PN03M	HEX NUT M8-1.25
35	PS01	PHLP HD SCR 10-24 x 1/2
36	P0621036	LOWER WHEEL COVER
37	PSB05	CAP SCREW 1/4-20 X 3/4
38	PN03-1	HEX NUT 3/4-16 (LH)
39	P0621039	LOWER WHEEL
40	P0621040	PULLEY COVER PLATE
41	P0621041	PULLEY
42	P0621042	SHAFT
43	PVA30	V-BELT A-30 4L300

REF	PART #	DESCRIPTION
44	P0621044	SHAFT
45	P6004	BALL BEARING 6004ZZ
46	P0621046	BLADE TENSION SCALE
47	PN02	HEX NUT 5/16-18
48	P0621048	KNOB 5/16-18 X 2
49	P0621049	STRAIN RELIEF
50	P0621050	POWER CORD
51	P0621051	MOTOR CORD
52	P0621052	KNOB
53	PSB05	CAP SCREW 1/4-20 X 3/4
54	P0621054	ADJUSTMENT SLEEVE
55	PN03	HEX NUT 3/4-16
56	P0621056	BEARING HOUSING
57	P0621057	PIN 6MM
58	P0621058	FLANGE BOLT 5/16-18 X 1-1/2
59	P0621059	COVER
60	PN04	HEX NUT 5/8-11
61	PW14	FLAT WASHER 5/8
62	PW02	FLAT WASHER 3/8
63	PB35	HEX BOLT 3/8-16 X 2-1/2
64	P0621064	MOTOR 1.25HP, 220V, 3-PHASE
64-1	P0621064-1	JUNCTION BOX REAR COVER
64-2	P0621064-2	JUNCTION BOX FRONT COVER
64-3	PS18	PHLP HD SCR 10-24 X 1/4
64-4	P0621064-4	3-CIRCUIT TERMINAL BLOCK
65	P0621065	ADJ HANDLE 3/8-16 X 1
66	PK12M	KEY 5 X 5 X 30
67	P0621067	HEX NUT 3/8-16
68	P0621068	DUST PORT 2.5"
69	PVA28	V-BELT A-28 4L280
70	PR05M	EXT RETAINING RING 15MM
71	P0621071	MOTOR PULLEY
72	P0621072	PULLEY
73	PF1005041	BRUSH
74	PN05	HEX NUT 1/4-20
75	P0621075	SWITCH COVER
76	PS01M	PHLP HD SCR M4-.7 x 18
77	PS17M	PHLP HD SCR M4-.7 X 6
78	PW02	FLAT WASHER 3/8
79	PB05	HEX BOLT 1/4-20 X 3/4
80	PS18	PHLP HD SCR 10-24 X 1/4
81	PN05	HEX NUT 1/4-20



Table/Blade Guides Parts Breakdown

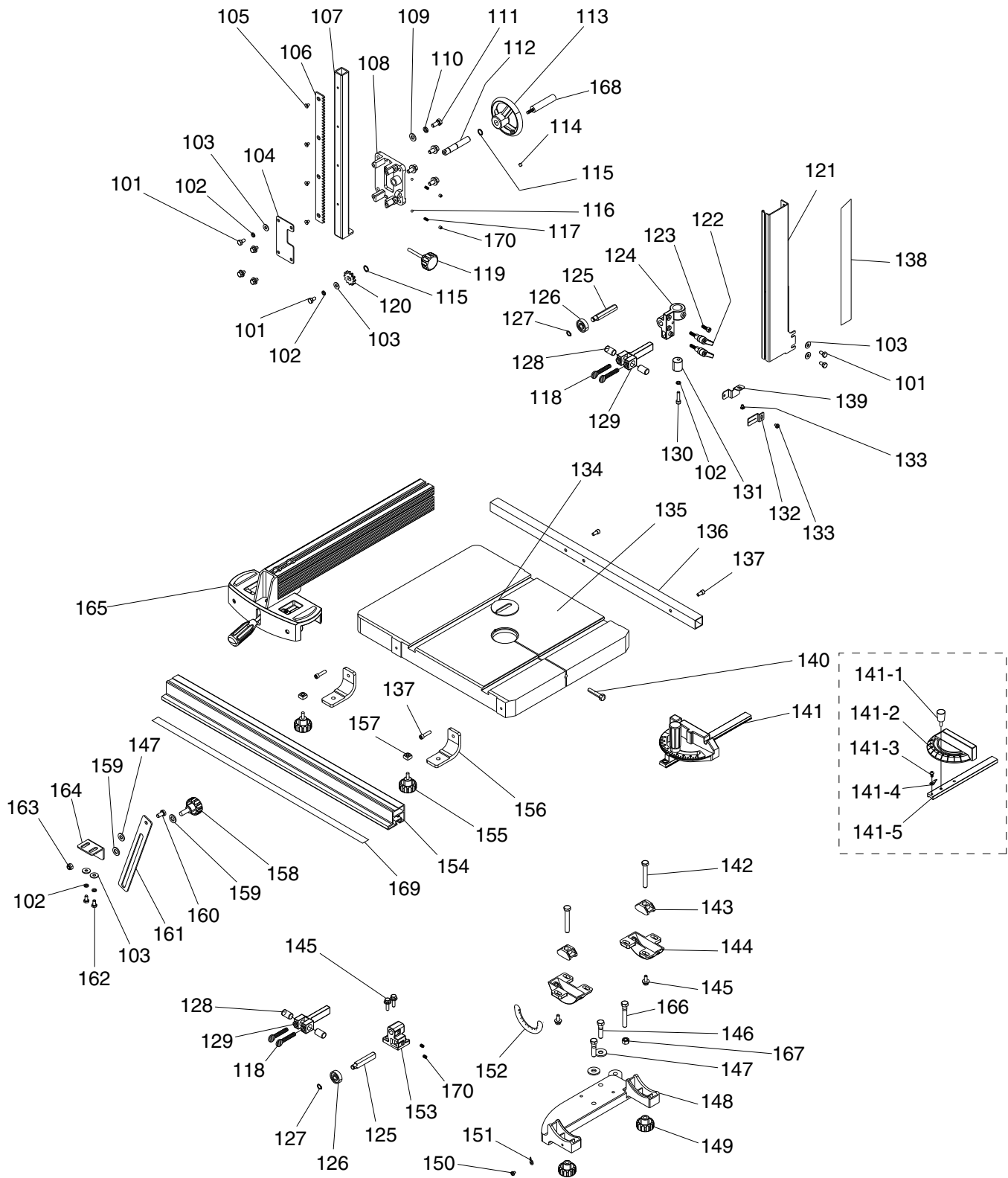

Secondary Parts Breakdown

REF	PART #	DESCRIPTION
101	PB51	HEX BOLT 1/4-20 X 3/8
102	PLW02	LOCK WASHER 1/4
103	PW06	FLAT WASHER 1/4
104	P0621104	GUIDE BAR COVER
105	P0621105	FLAT HD CAP SCR M5-.8 X 8
106	P0621106	RACK
107	P0621107	GUIDE BAR
108	P0621108	BRACKET
109	PW07	FLAT WASHER 5/16
110	PLW01	LOCK WASHER 5/16
111	PB32	HEX BOLT 5/16-18 X 5/8
112	P0621112	PINION SHAFT
113	P0621113	HANDWHEEL
114	PSS02	SET SCREW 5/16-18 X 3/8
115	PR47M	EXT RETAINING RING 13MM
116	P0621116	BALL
117	P0621117	COMPRESSION SPRING
118	P0621118	THUMB SCREW 1/4-20 X 1/2
119	P0621119	KNOB 5/16-18 X 2
120	P0621120	PINION GEAR
121	P0621121	BLADE GUARD
122	P0621122	THUMB SCREW 1/4-20 X 3/4
123	PSB05	CAP SCREW 1/4-20 X 3/4
124	P0621124	UPPER GUIDE BRACKET
125	P0621125	SUPPORT BEARING SHAFT
126	P6200	BALL BEARING 6200ZZ
127	PR01M	EXT RETAINING RING 10MM
128	P0621128	BLADE GUIDE BLOCK
129	P0621129	BLADE GUIDE HOLDER
130	P0621130	CAP SCREW 1/4-20 X 7/8
131	P0621131	ECCENTRIC GUIDE POST
132	P0621132	GUIDE POST POINTER
133	PS01	PHLP HD SCR 10-24 X 1/2
134	P0621134	TABLE INSERT
135	P0621135	TABLE
136	P0621136	REAR FENCE RAIL
137	PSB06	CAP SCREW 1/4-20 X 1
138	P0621138	GUIDE POST SCALE

REF	PART #	DESCRIPTION
139	P0621139	POINTER PLATE
140	P0621140	TABLE PIN
141	P0621141	MITER GAUGE ASSY
141-1	P0621141-1	MITER GAUGE HANDLE 5/16"
141-2	P0621141-2	MITER GAUGE BODY
141-3	PS18	PHLP HD SCR 10-24 X 1/4
141-4	P0621141-4	MITER GAUGE POINTER
141-5	P0621141-5	MITER GAUGE BAR
142	PB35	HEX BOLT 3/8-16 X 2-1/2
143	P0621143	CLAMP SHOE
144	P0621144	TRUNNION
145	PFB15	FLANGE BOLT 1/4-20 X 3/4
146	PB12	HEX BOLT 5/16-18 X 1-1/4
147	PW07	FLAT WASHER 5/16
148	P0621148	TRUNNION BASE
149	P0621149	KNOB 3/8-16
150	PS18	PHLP HD SCR 10-24 X 1/4
151	P0621151	TABLE TILT POINTER
152	P0621152	TABLE TILT SCALE
153	P0621153	LOWER GUIDE BRACKET
154	P0621154	FRONT FENCE RAIL
155	P0621155	KNOB 5/16-18 X 5/8
156	P0621156	RAIL BRACKET
157	P0621157	SQUARE NUT
158	P0621158	KNOB 3/8-16 X 1
159	PW02	FLAT WASHER 3/8
160	PB03	HEX BOLT 5/16-18 X 1
161	P0621161	ANGLE ADJUSTMENT BAR
162	PB19	HEX BOLT 1/4-20 X 1/2
163	PLN03	LOCK NUT 5/16-18
164	P0621164	ADJUSTMENT BAR BRACKET
165	P0621165	COMPLETE FENCE ASSY
166	PB16	HEX BOLT 3/8-16 X 1-1/2
167	PN08	HEX NUT 3/8-16
168	P0621168	HANDWHEEL HANDLE
169	P0621169	FENCE SCALE
170	PSS03	SET SCREW 1/4-20 X 3/8



Stand Parts Breakdown

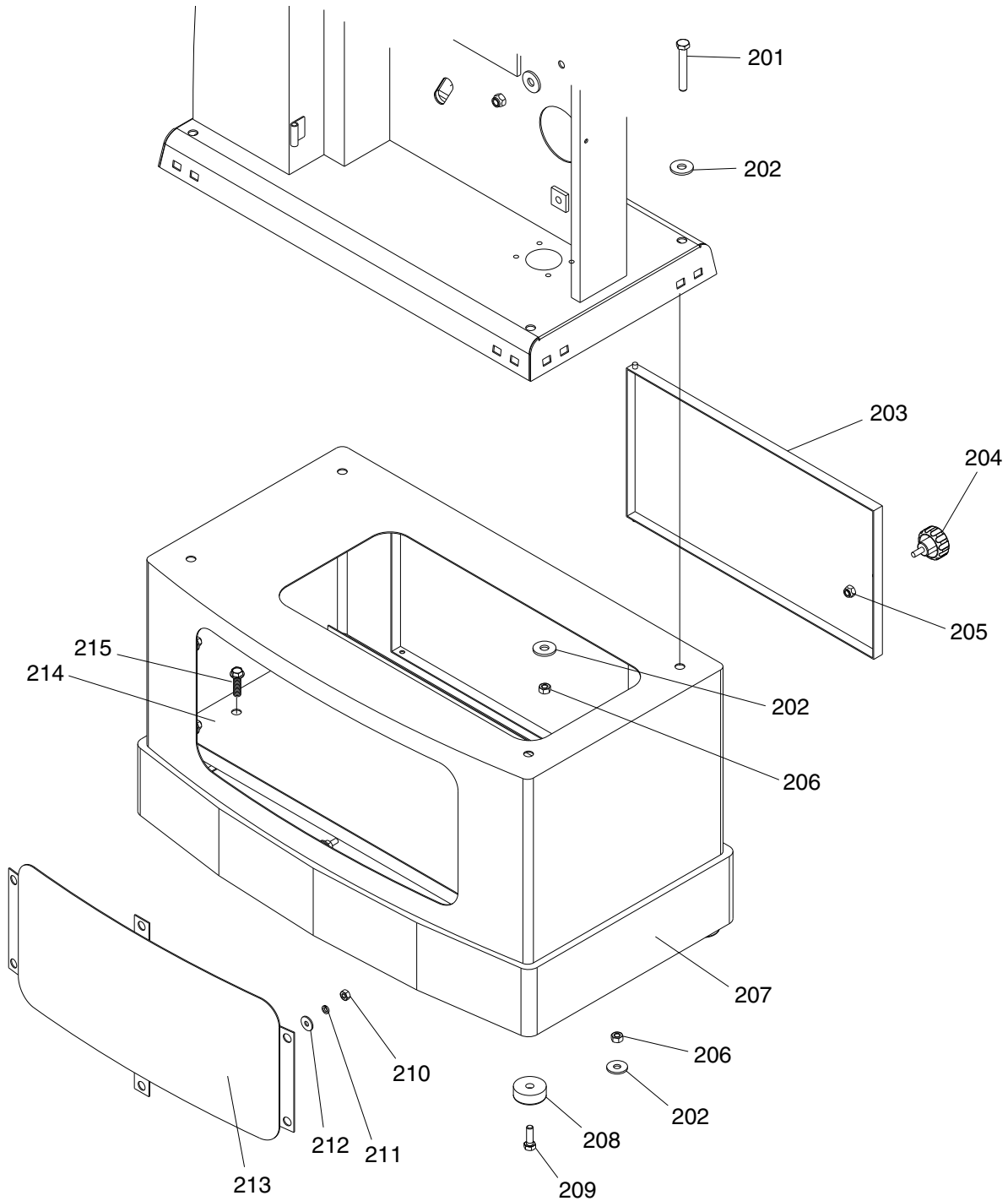

REF	PART #	DESCRIPTION
201	PB04	HEX BOLT 5/16-18 X 3
202	PW07	FLAT WASHER 5/16
203	P0621203	STAND GUARD
204	P0621204	KNOB 5/16-18 X 3/4
205	PLN03	LOCK NUT 5/16-18
206	PN02	HEX NUT 5/16-18
207	P0621207	STAND
208	P0621208	FOOT

REF	PART #	DESCRIPTION
209	PB03	HEX BOLT 5/16-18 X 1
210	PN05	HEX NUT 1/4-20
211	PLW02	LOCK WASHER 1/4
212	PW06	FLAT WASHER 1/4
213	P0621213	STAND INSET PLATE
214	P0621214	CABINET BOTTOM PLATE
215	PFB15	FLANGE BOLT 1/4-20 X 3/4



Fence Parts Breakdown

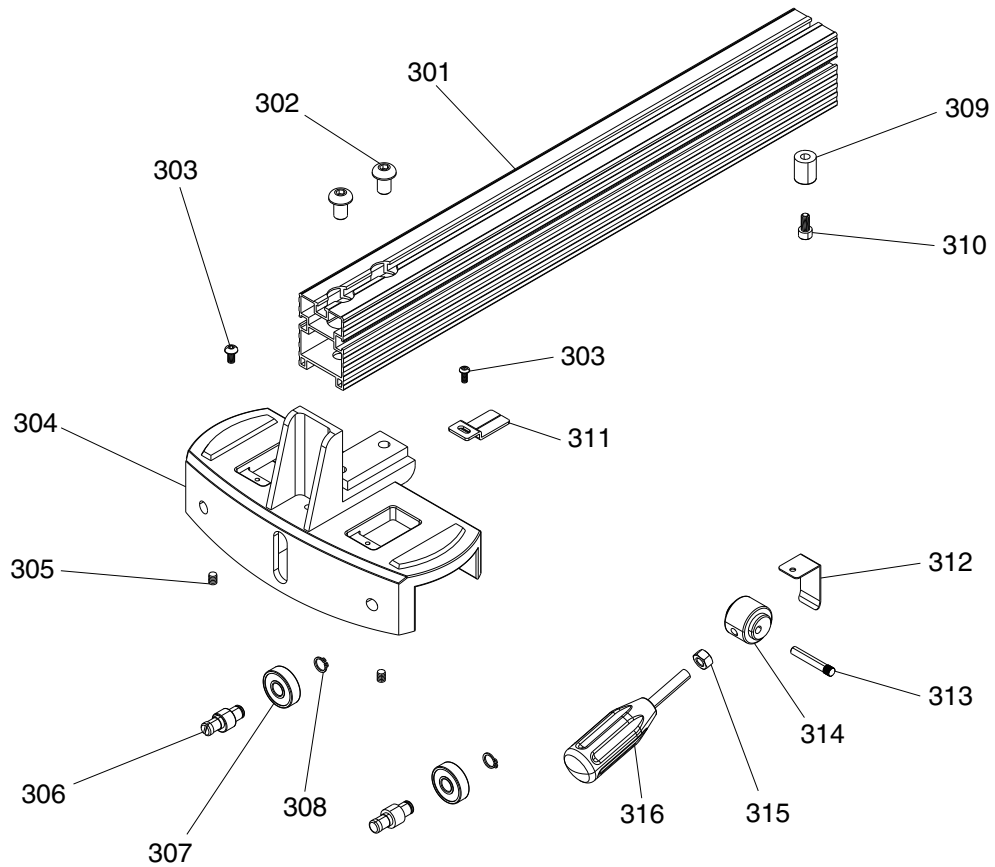

REF	PART #	DESCRIPTION
300	P0621300	COMPLETE FENCE ASSY
301	P0621301	FENCE BODY
302	P0621302	BUTTON HD CAP SCR M10-1.5 X 16
303	PS09M	PHLP HD SCR M5-.8 X 10
304	P0621304	FENCE BASE
305	PSS03	SET SCREW 1/4-20 X 3/8
306	P0621306	ECCENTRIC SHAFT
307	P6200	BALL BEARING 6200ZZ
308	PR45M	INT RETAINING RING 10MM

REF	PART #	DESCRIPTION
309	P0621309	RUNNER
310	PSB01M	CAP SCREW M6-1 X 16
311	P0621311	FENCE POINTER
312	P0621312	PLATE
313	P0621313	PIN
314	P0621314	LOCK MECHANISM
315	PN03M	HEX NUT M8-1.25
316	P0621316	FENCE HANDLE M8-1.25



Safety Labels Parts Breakdown

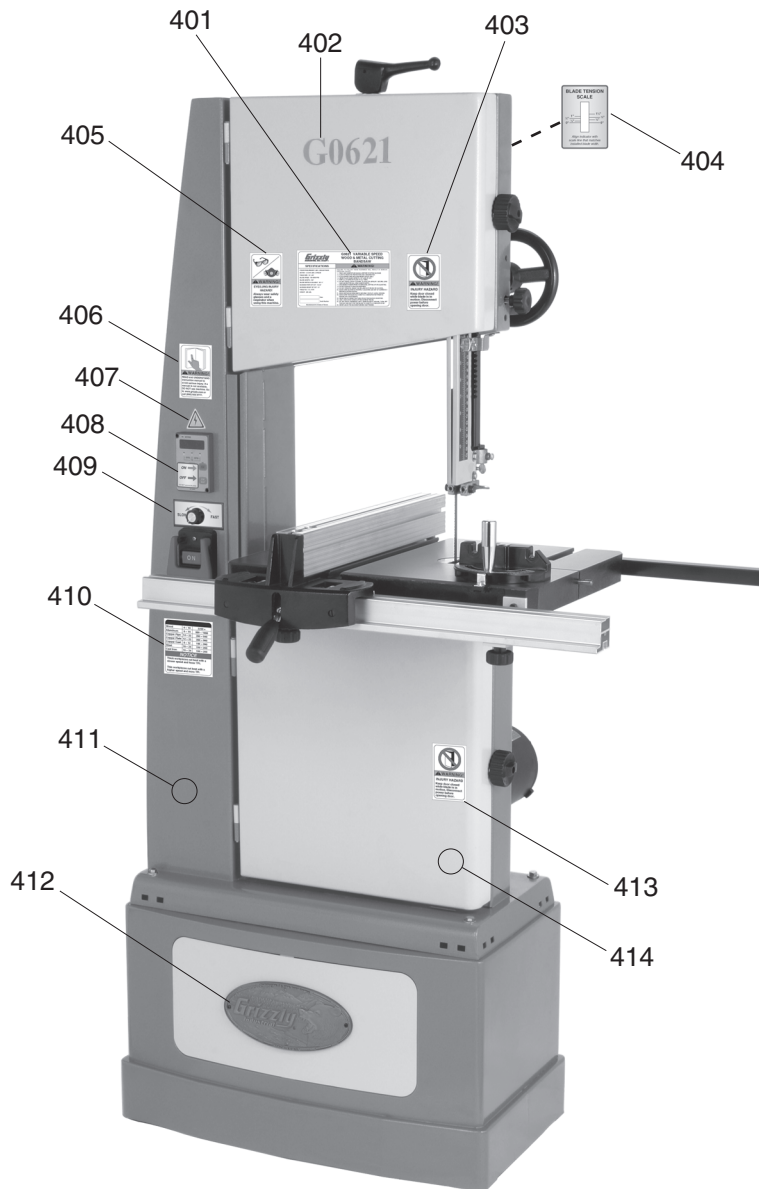

REF	PART #	DESCRIPTION
401	P0621401	MACHINE ID LABEL
402	P0621402	G0621 MODEL # LABEL
403	P0621403	DOOR CLOSED LABEL
404	P0621404	BLADE TENSION LABEL
405	P0621405	GLASSES/RESPIRATOR LABEL
406	PLABEL-12A	READ MANUAL LABEL
407	PLABEL-14	ELECTRICITY LABEL

REF	PART #	DESCRIPTION
408	P0621408	MOTOR SWITCH ON/OFF LABEL
409	P0621409	SPEED DIAL LABEL
410	P0621410	CUTTING CHART LABEL
411	PPAINT-1	"GRIZZLY GREEN" TOUCH-UP PAINT
412	P0621412	GRIZZLY LOGO PLATE
413	P0621403	DOOR CLOSED LABEL
414	PPAINT-14	"PUTTY" TOUCH-UP PAINT

WARNING

Safety labels warn about machine hazards and ways to prevent injury. The owner of this machine **MUST** maintain the original location and readability of the labels on the machine. If any label is removed or becomes unreadable, **REPLACE** that label before using the machine again. Contact Grizzly at (800) 523-4777 or www.grizzly.com to order new labels.





WARRANTY CARD

Name _____

Street _____

City _____ State _____ Zip _____

Phone # _____ Email _____ Invoice # _____

Model # _____ Order # _____ Serial # _____

The following information is given on a voluntary basis. It will be used for marketing purposes to help us develop better products and services. **Of course, all information is strictly confidential.**

1. How did you learn about us?

- Advertisement
- Card Deck
- Friend
- Website
- Catalog
- Other:

2. Which of the following magazines do you subscribe to?

- | | | |
|---|--|---|
| <input type="checkbox"/> Cabinet Maker | <input type="checkbox"/> Popular Mechanics | <input type="checkbox"/> Today's Homeowner |
| <input type="checkbox"/> Family Handyman | <input type="checkbox"/> Popular Science | <input type="checkbox"/> Wood |
| <input type="checkbox"/> Hand Loader | <input type="checkbox"/> Popular Woodworking | <input type="checkbox"/> Wooden Boat |
| <input type="checkbox"/> Handy | <input type="checkbox"/> Practical Homeowner | <input type="checkbox"/> Woodshop News |
| <input type="checkbox"/> Home Shop Machinist | <input type="checkbox"/> Precision Shooter | <input type="checkbox"/> Woodsmith |
| <input type="checkbox"/> Journal of Light Cont. | <input type="checkbox"/> Projects in Metal | <input type="checkbox"/> Woodwork |
| <input type="checkbox"/> Live Steam | <input type="checkbox"/> RC Modeler | <input type="checkbox"/> Woodworker West |
| <input type="checkbox"/> Model Airplane News | <input type="checkbox"/> Rifle | <input type="checkbox"/> Woodworker's Journal |
| <input type="checkbox"/> Modeltec | <input type="checkbox"/> Shop Notes | <input type="checkbox"/> Other: |
| <input type="checkbox"/> Old House Journal | <input type="checkbox"/> Shotgun News | |

3. What is your annual household income?

- \$20,000-\$29,000
- \$30,000-\$39,000
- \$40,000-\$49,000
- \$50,000-\$59,000
- \$60,000-\$69,000
- \$70,000+

4. What is your age group?

- 20-29
- 30-39
- 40-49
- 50-59
- 60-69
- 70+

5. How long have you been a woodworker/metalworker?

- 0-2 Years
- 2-8 Years
- 8-20 Years
- 20+ Years

6. How many of your machines or tools are Grizzly?

- 0-2
- 3-5
- 6-9
- 10+

7. Do you think your machine represents a good value? Yes No

8. Would you recommend Grizzly Industrial to a friend? Yes No

9. Would you allow us to use your name as a reference for Grizzly customers in your area?
Note: We never use names more than 3 times. Yes No

10. Comments: _____

CUT ALONG DOTTED LINE

FOLD ALONG DOTTED LINE



Place
Stamp
Here



GRIZZLY INDUSTRIAL, INC.
P.O. BOX 2069
BELLINGHAM, WA 98227-2069



FOLD ALONG DOTTED LINE

Send a Grizzly Catalog to a friend:

Name _____
Street _____
City _____ State _____ Zip _____

TAPE ALONG EDGES--PLEASE DO NOT STAPLE

WARRANTY AND RETURNS

Grizzly Industrial, Inc. warrants every product it sells for a period of **1 year** to the original purchaser from the date of purchase. This warranty does not apply to defects due directly or indirectly to misuse, abuse, negligence, accidents, repairs or alterations or lack of maintenance. This is Grizzly's sole written warranty and any and all warranties that may be implied by law, including any merchantability or fitness, for any particular purpose, are hereby limited to the duration of this written warranty. We do not warrant or represent that the merchandise complies with the provisions of any law or acts unless the manufacturer so warrants. In no event shall Grizzly's liability under this warranty exceed the purchase price paid for the product and any legal actions brought against Grizzly shall be tried in the State of Washington, County of Whatcom.

We shall in no event be liable for death, injuries to persons or property or for incidental, contingent, special, or consequential damages arising from the use of our products.

To take advantage of this warranty, contact us by mail or phone and give us all the details. We will then issue you a "Return Number," which must be clearly posted on the outside as well as the inside of the carton. We will not accept any item back without this number. Proof of purchase must accompany the merchandise.

The manufacturers reserve the right to change specifications at any time because they constantly strive to achieve better quality equipment. We make every effort to ensure that our products meet high quality and durability standards and we hope you never need to use this warranty.

Please feel free to write or call us if you have any questions about the machine or the manual.

Thank you again for your business and continued support. We hope to serve you again soon.

grizzly.com[®]

TOOL WEBSITE

Buy Direct and Save with Grizzly[®] – Trusted, Proven and a Great Value!
~Since 1983~

*Visit Our Website Today For
Current Specials!*

**ORDER
24 HOURS A DAY!
1-800-523-4777**

