

Grizzly *Industrial, Inc.*®

MODEL G7297 12" DISC SANDER OWNER'S MANUAL

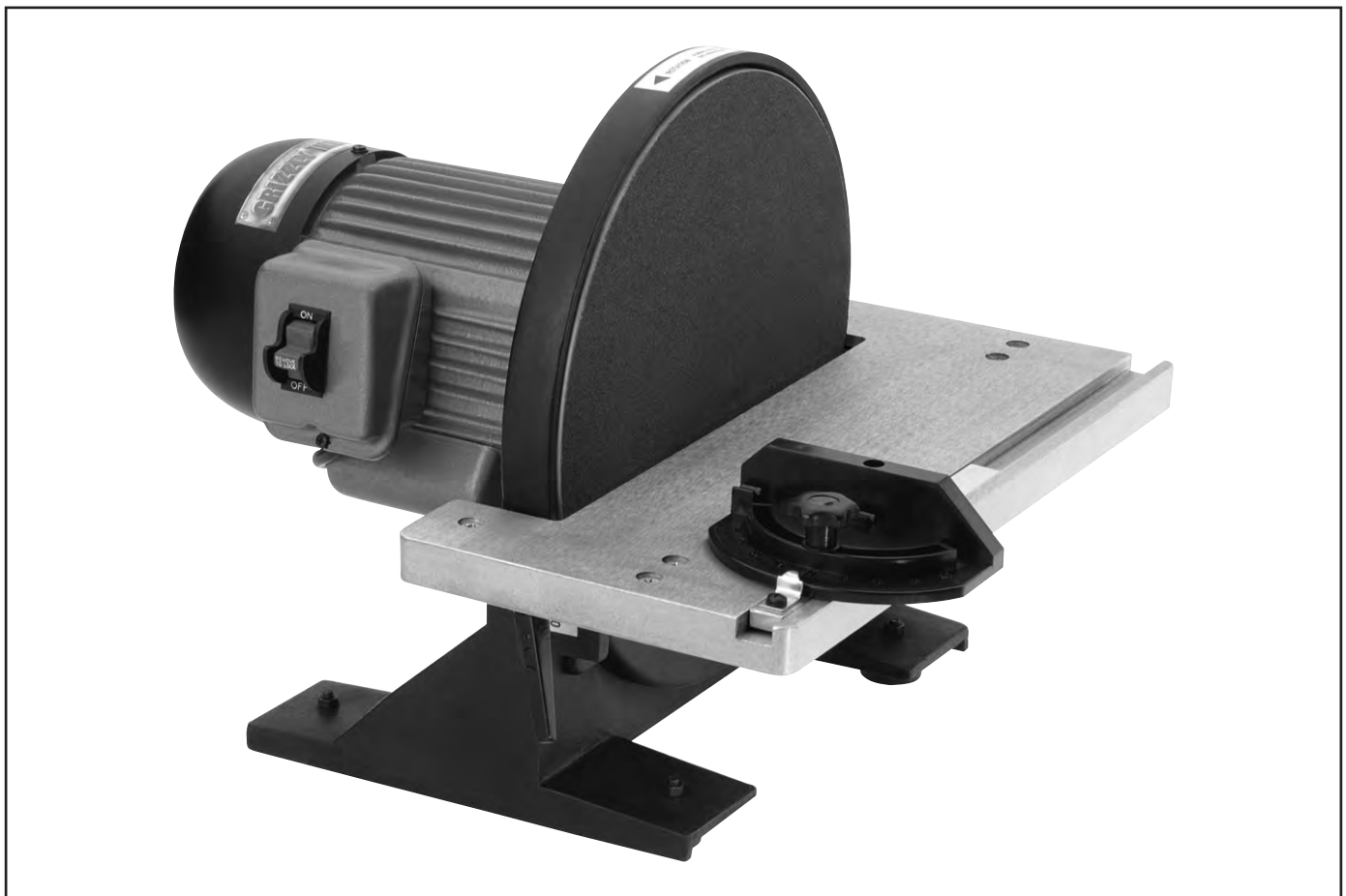

COPYRIGHT © JUNE, 2003 BY GRIZZLY INDUSTRIAL, INC. REVISED JULY, 2009 (TR)
**WARNING: NO PORTION OF THIS MANUAL MAY BE REPRODUCED IN ANY SHAPE
OR FORM WITHOUT THE WRITTEN APPROVAL OF GRIZZLY INDUSTRIAL, INC.**
(FOR MACHINES MFG. SINCE 10/98) PRINTED IN CHINA



WARNING!

This manual provides critical safety instructions on the proper setup, operation, maintenance and service of this machine/equipment.

Failure to read, understand and follow the instructions given in this manual may result in serious personal injury, including amputation, electrocution or death.

The owner of this machine/equipment is solely responsible for its safe use. This responsibility includes but is not limited to proper installation in a safe environment, personnel training and usage authorization, proper inspection and maintenance, manual availability and comprehension, application of safety devices, blade/cutter integrity, and the usage of personal protective equipment.

The manufacturer will not be held liable for injury or property damage from negligence, improper training, machine modifications or misuse.



WARNING!

Some dust created by power sanding, sawing, grinding, drilling, and other construction activities contains chemicals known to the State of California to cause cancer, birth defects or other reproductive harm. Some examples of these chemicals are:

- **Lead from lead-based paints.**
- **Crystalline silica from bricks, cement and other masonry products.**
- **Arsenic and chromium from chemically-treated lumber.**

Your risk from these exposures varies, depending on how often you do this type of work. To reduce your exposure to these chemicals: Work in a well ventilated area, and work with approved safety equipment, such as those dust masks that are specially designed to filter out microscopic particles.

TABLE OF CONTENTS

SECTION 1: SAFETY	2
Safety Instructions for Power Tools	2
Additional Safety Instructions for Sanders	4
SECTION 2: INTRODUCTION	5
SECTION 3: CIRCUIT REQUIREMENTS	6
110 Volt Operation	6
Grounding	7
Extension Cords	7
SECTION 4: IDENTIFICATION	8
SECTION 5: SET UP	9
G7297 Inventory	9
Unpacking	9
Site Considerations	10
SECTION 6: ADJUSTMENTS	11
Table Tilt	11
Miter Gauge	12
Attaching Sandpaper	12
Aligning Table	13
SECTION 7: OPERATIONS	14
Disc Sanding	14
Miter Sanding	15
Angle Sanding	15
SECTION 8: MAINTENANCE	16
Maintenance Safety	16
Schedule	16
SECTION 9: REFERENCE INFO	17
Aftermarket Accessories	17
Troubleshooting Guide	18
Machine Data Sheet	19
Parts Diagrams and Lists	20
Warranty and Returns	22

SECTION 1: SAFETY

WARNING

For Your Own Safety Read Instruction Manual Before Operating This Equipment

The purpose of safety symbols is to attract your attention to possible hazardous conditions. This manual uses a series of symbols and signal words which are intended to convey the level of importance of the safety messages. The progression of symbols is described below. Remember that safety messages by themselves do not eliminate danger and are not a substitute for proper accident prevention measures.



Indicates an imminently hazardous situation which, if not avoided, WILL result in death or serious injury.



Indicates a potentially hazardous situation which, if not avoided, COULD result in death or serious injury.



Indicates a potentially hazardous situation which, if not avoided, MAY result in minor or moderate injury. It may also be used to alert against unsafe practices.

NOTICE

This symbol is used to alert the user to useful information about proper operation of the equipment.

WARNING

Safety Instructions for Power Tools

1. **KEEP GUARDS IN PLACE** and in working order.
2. **REMOVE ADJUSTING KEYS AND WRENCHES.** Form habit of checking to see that keys and adjusting wrenches are removed from tool before turning on.
3. **KEEP WORK AREA CLEAN.** Cluttered areas and benches invite accidents.
4. **NEVER USE IN DANGEROUS ENVIRONMENT.** DO NOT use power tools in damp or wet locations, or where any flammable or noxious fumes may exist. Keep work area well lighted.
5. **KEEP CHILDREN AND VISITORS AWAY.** All children and visitors should be kept at a safe distance from work area.
6. **MAKE WORKSHOP CHILD PROOF** with padlocks, master switches, or by removing starter keys.
7. **NEVER FORCE TOOL.** It will do the job better and safer at the rate for which it was designed.
8. **USE THE RIGHT TOOL.** DO NOT force the tool or attachment to do a job for which it was not designed.

WARNING

Safety Instructions for Power Tools

- 9. USE PROPER EXTENSION CORD.** Make sure your extension cord is in good condition. Conductor size should be in accordance with the chart below. The amperage rating should be listed on the motor or tool nameplate. An undersized cord will cause a drop in line voltage resulting in loss of power and overheating. Your extension cord must also contain a ground wire and plug pin. Always repair or replace extension cords if they become damaged.

Minimum Gauge for Extension Cords

AMP RATING	LENGTH		
	25ft	50ft	100ft
0-6	16	16	16
7-10	16	16	14
11-12	16	16	14
13-16	14	12	12
17-20	12	12	10
21-30	10	10	No

- 10. WEAR PROPER APPAREL.** DO NOT wear loose clothing, gloves, neckties, rings, bracelets, or other jewelry which may get caught in moving parts. Non-slip footwear is recommended. Wear protective hair covering to contain long hair.
- 11. ALWAYS USE SAFETY GLASSES.** Also use face or dust mask if sanding operation is dusty. Everyday eyeglasses only have impact resistant lenses, they are NOT safety glasses.
- 12. SECURE WORK.** Use clamps or a vise to hold work when practical. It's safer than using your hand and frees both hands to operate tool.
- 13. DO NOT OVER-REACH.** Keep proper footing and balance at all times.
- 14. MAINTAIN TOOLS WITH CARE.** Keep tools sharp and clean for best and safest performance. Follow instructions for lubricating and changing accessories.

- 15. USE RECOMMENDED ACCESSORIES.** Consult the owner's manual for recommended accessories. The use of improper accessories may cause risk of injury.

- 16. REDUCE THE RISK OF UNINTENTIONAL STARTING.** On machines with magnetic contact starting switches there is a risk of starting if the machine is bumped or jarred. Always disconnect from power source before adjusting or servicing. Make sure switch is in OFF position before reconnecting.

- 17. CHECK DAMAGED PARTS.** Before further use of the tool, a guard or other part that is damaged should be carefully checked to determine that it will operate properly and perform its intended function. Check for alignment of moving parts, binding of moving parts, breakage of parts, mounting, and any other conditions that may affect its operation. A guard or other part that is damaged should be properly repaired or replaced.

- 18. NEVER LEAVE TOOL RUNNING UNATTENDED. TURN POWER OFF.** DO NOT leave tool until it comes to a complete stop.

- 19. NEVER OPERATE A MACHINE WHEN TIRED, OR UNDER THE INFLUENCE OF DRUGS OR ALCOHOL.** Full mental alertness is required at all times when running a machine.

- 20. NEVER ALLOW UNSUPERVISED OR UNTRAINED PERSONNEL TO OPERATE THE MACHINE.** Make sure any instructions you give in regards to machine operation are approved, correct, safe, and clearly understood.

- 21. IF AT ANY TIME YOU ARE EXPERIENCING DIFFICULTIES** performing the intended operation, stop using the machine! Then contact our service department or ask a qualified expert how the operation should be performed.

WARNING

Additional Safety Instructions for Sanders

1. **BE AWARE OF DISC ROTATION** when sanding.
2. **KEEP FINGERTIPS AWAY** from the moving disc. Serious injury could result if skin contacts abrasives or moving parts.
3. **NEVER USE EXCESSIVE FORCE** when sanding. Doing this greatly increases the chances of personal injury and motor overload.
4. **ALWAYS FEED THE WORK** against the direction of rotation.
5. **USE A DUST MASK** or respirator when sanding, as well as eye and ear protection, even if you have a reliable method of dust collection.
6. **IF THERE IS ANY DOUBT ABOUT THE STABILITY** or integrity of the material to be sanded, **do not sand it**.
7. **DO NOT OPERATE SANDER** with a damaged or badly worn disc or belt.
8. **WHEN DISC SANDING**, feed material into the portion of the disc spinning *down* toward the table.
9. **TIE BACK LONG HAIR** and remove any loose-fitting clothing or jewelry that could be caught up in the sander's disc, belt, or other moving machine parts.
10. **BE AWARE THAT CERTAIN WOODS MAY CAUSE AN ALLERGIC REACTION** in people and animals, especially when exposed to fine dust. Make sure you know what type of wood dust you will be exposed to and always wear an approved respirator.
11. **HABITS — GOOD OR BAD** — are hard to break. Develop good habits and safety will become second nature to you.

WARNING

Like all power tools, there is danger associated with the Model G7297 12" Disc Sander. Accidents are frequently caused by lack of familiarity or failure to pay attention. Use this tool with respect and caution to lessen the possibility of operator injury. If normal safety precautions are overlooked or ignored, serious personal injury may occur.

CAUTION

No list of safety guidelines can be complete. Every shop environment is different. Always consider safety first, as it applies to your individual working conditions. Use this and other machinery with caution and respect. Failure to do so could result in serious personal injury, damage to equipment or poor work results.

SECTION 2: INTRODUCTION

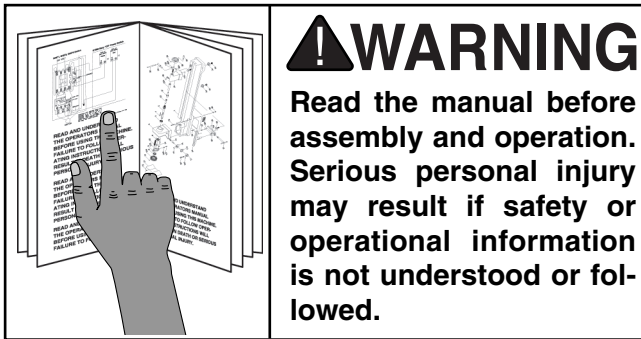

WARNING
Read the manual before assembly and operation. Serious personal injury may result if safety or operational information is not understood or followed.

We are proud to offer the Model G7297 Disc Sander. This 12" disc sander is a part of a growing Grizzly family of fine woodworking machinery. When used according to the guidelines set forth in this manual, you can expect years of trouble-free, enjoyable operation and proof of Grizzly's commitment to customer satisfaction.

The Model G7297 Disc Sander features a 1 HP, 110V, 1725 RPM motor, a 12" sanding disc, a 17¼" x 8¼" tilting cast aluminum table, a miter gauge, and a built in 2" dust port. A number of sanding disc grits for the Model G7297 Disc Sander are available through the Grizzly catalog.

We are also pleased to provide this manual with the Model G7297 Disc Sander. It was written to guide you through assembly, review safety considerations, and cover general operating procedures. It represents our effort to produce the best documentation possible.

If you have any comments regarding this manual, please write to us at the address below:

Grizzly Industrial, Inc.
c/o Technical Documentation
P.O. Box 2069
Bellingham, WA 98227-2069

Most importantly, we stand behind our machines. If you have any service questions or parts requests, please call or write us at the location listed below.

Grizzly Industrial, Inc.
1203 Lycoming Mall Circle
Muncy, PA 17756
Phone: (570) 546-9663
Fax: (800) 438-5901
E-Mail: techsupport@grizzly.com
Web Site: <http://www.grizzly.com>

The specifications, drawings, and photographs illustrated in this manual represent the Model G7297 Disc Sander as supplied when the manual was prepared. However, owing to Grizzly's policy of continuous improvement, changes may be made at any time with no obligation on the part of Grizzly. For your convenience, we always keep current Grizzly manuals available on our website at www.grizzly.com. Any updates to your machine will be reflected in these manuals as soon as they are complete. Visit our site often to check for the latest updates to this manual!

SECTION 3: CIRCUIT REQUIREMENTS

110 Volt Operation

Amperage Draw

The Model G7297 Disc Sander motor is wired to operate at 110V and will draw the following load:

Motor Load 10 Amps

Plug Type

The Model G7297 Disc Sander is supplied with a NEMA 5-15 plug. See **Figure 1** for a NEMA 5-15 plug and grounded outlet. **DO NOT** modify the plug or power cord in any way.

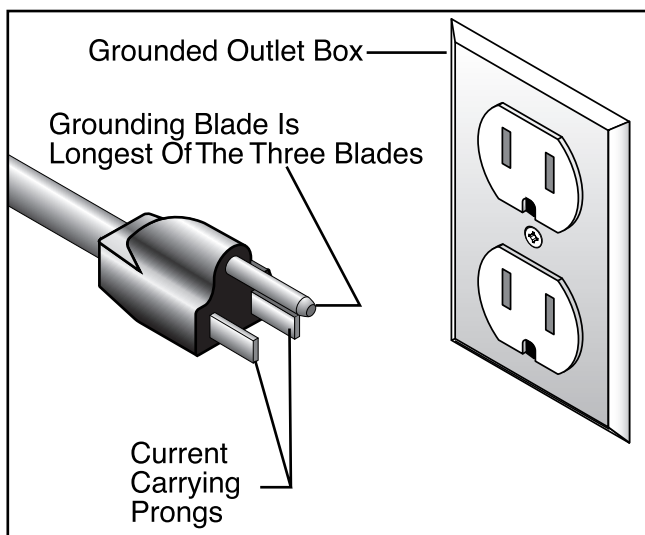

Figure 1. NEMA 5-15 plug and grounded outlet.

Circuit Breaker Requirements

We recommend that you dedicate a circuit to your machine. Use the following guideline when choosing a circuit breaker (circuit breakers rated any higher are not adequate to protect the circuit):

Recommended Circuit Breaker 15 Amp

Your Circuit Capacity

Always check to see if the wires in your circuit are capable of handling the amperage load from your machine. If you are unsure, consult a qualified electrician.

If you operate this machine on any circuit that is already close to its load capacity, it may blow a fuse or trip a circuit breaker. If the circuit is not overloaded and the fuse or circuit breaker still trips, contact a qualified electrician or our Service Department at (570) 546-9663.

⚠ WARNING

Serious personal injury could occur if you connect your machine to the power source before you have completed the assembly process. DO NOT connect the machine to the power source until instructed to do so.



Grounding

In the event of an electrical short, grounding reduces the risk of electric shock by providing a path of least resistance to disperse electric current. This tool is equipped with a power cord that has an equipment-grounding prong. The outlet must be properly installed and grounded in accordance with all local codes and ordinances.

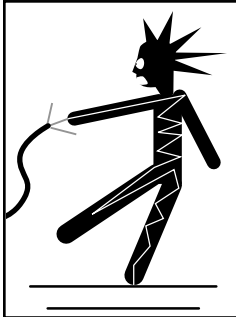

⚠ WARNING
Electrocution or a fire can result if the machine is not grounded correctly. Make sure all electrical circuits are grounded. **DO NOT** use ungrounded machines.

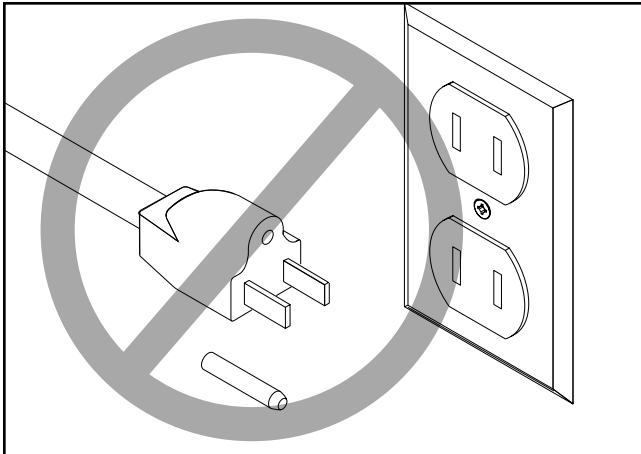

⚠ CAUTION
This machine must have a ground prong in the plug to help ensure that it is grounded. **DO NOT** remove ground prong from plug to fit into a two-pronged outlet! If the plug will not fit the outlet, have the proper outlet installed by a qualified electrician.

NOTICE
The wire on the power cord with green or green and yellow striped insulation is the grounding conductor.



Extension Cords

110V Operation

If you find it necessary to use an extension cord at 110V:

- Make sure the cord is rated Standard Service (grade S) or better.
- The extension cord must also contain a ground wire and plug pin.
- Use at least a 16 gauge cord if the cord is 50 feet long or less.
- **DO NOT** use a cord longer than 100 feet!



⚠ CAUTION
No single list of electrical guidelines can be comprehensive for all shop environments. Operating this machinery may require additional electrical upgrades specific to your machine and shop environment. It is your responsibility to make sure your electrical systems comply with all local electrical codes and ordinances.

SECTION 4: IDENTIFICATION

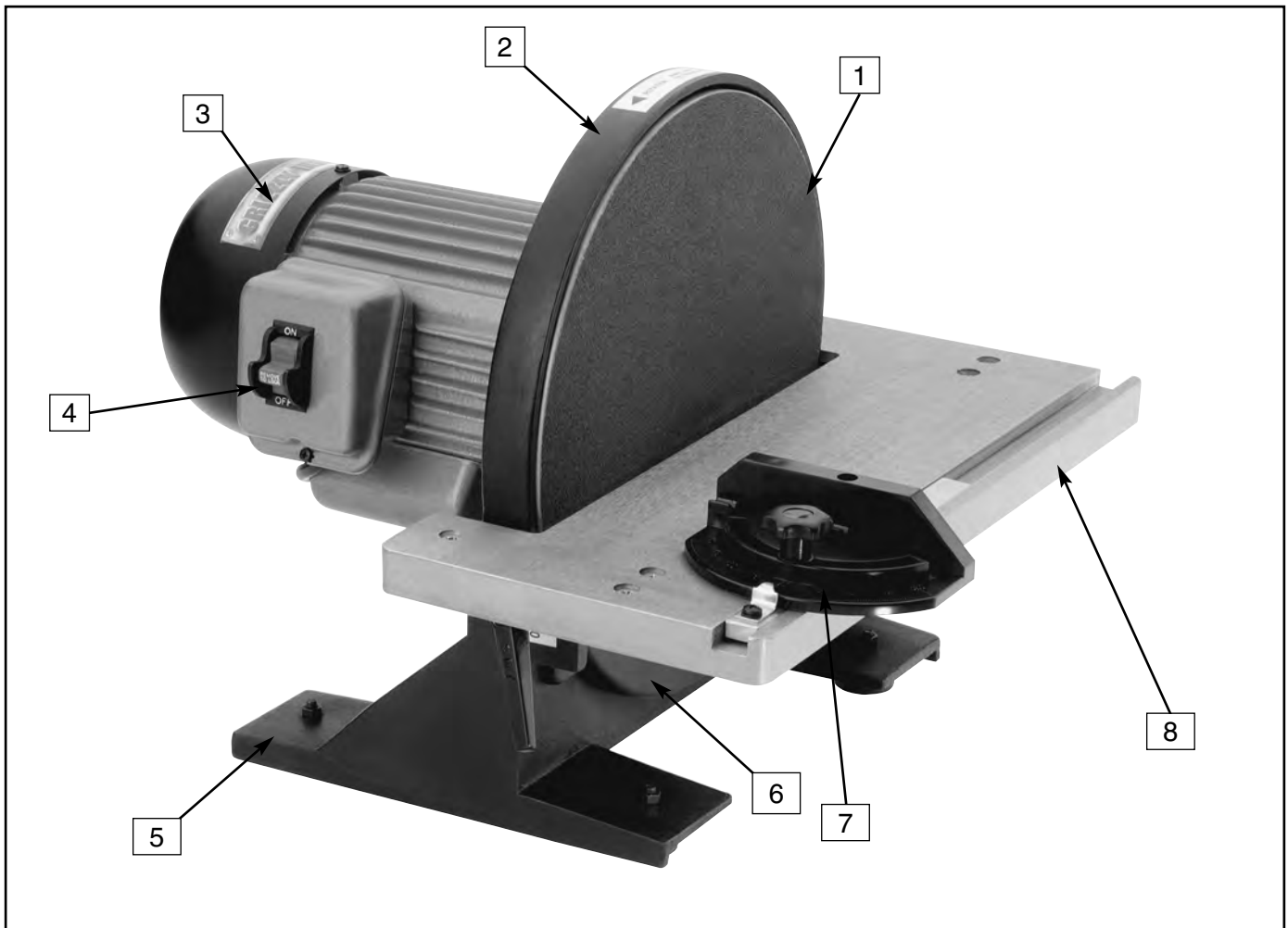

The following is a list of controls and components on the Model G7297 Disc Sander. Please take time to become familiar with each item and its location. These items will be used throughout the manual and knowing them is essential to understanding the instructions and terminology used in this manual.

1. Aluminum Disc (Sanding Disc Attached)
2. Disc Guard
3. Motor
4. *ON/OFF* Switch
5. Base
6. Dust Port (Opening Not Visible)
7. Miter Gauge
8. Work Table

SECTION 5: SET UP

Unpacking

The machine is shipped from the manufacturer in a carefully packed cardboard box. If you discover the machine is damaged after you've signed for delivery, and the truck and driver are gone, you will need to file a freight claim with the carrier. Save the containers and all packing materials for possible inspection by the carrier or its agent. Without the packing materials, filing a freight claim can be difficult. If you need assistance determining whether you need to file a freight claim, or with the procedure to file one, please contact our Customer Service.

	<p>⚠️ WARNING The Model G7297 Disc Sander weighs 66 lbs. Personal injury could occur if the machine is moved without additional assistance. Seek help when moving or lifting the machine.</p>
--	--

	<p>⚠️ CAUTION Sharp edges on metal parts may cause personal injury. Examine the edges of all metal parts before handling.</p>
---	--

When you are completely satisfied with the condition of your shipment, inventory its parts.



G7297 Inventory

- Motor and Disc Assembly1
- Miter Gauge.....1
- 12" PSA Sanding Disc.....1
- Manual.....1

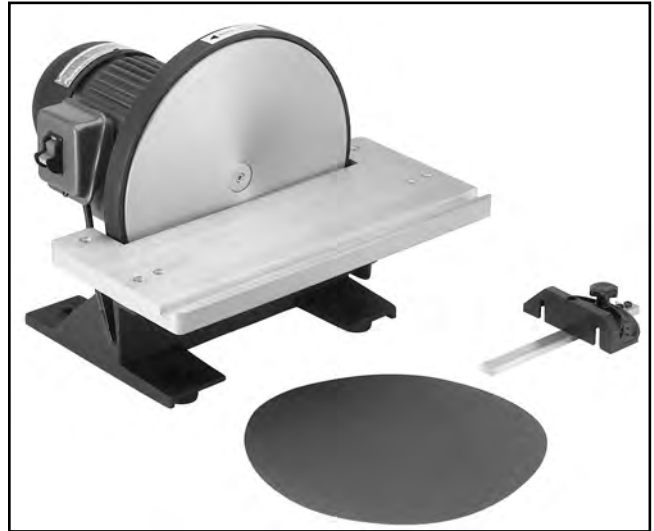

Figure 2. G7297 Inventory.

Site Considerations

Weight Load

The Model G7297 Disc Sander is a small weight load with a small footprint. Most shop floors and workbenches should be sufficient to carry the weight of the machine. Reinforce the floor and workbench if you question its ability to support the weight.

Working Clearance

Working clearances can be thought of as the distances between machines and obstacles that allow safe operation of every machine without limitation. Consider existing and anticipated machine needs, size of material to be processed through each machine, and space for auxiliary stands or work tables. Also consider the relative position of each machine to one another for efficient material handling.

Lighting And Outlets

Lighting should be bright enough to eliminate shadow and prevent eye strain. Electrical circuits should be dedicated or large enough to handle the amperage draw. Outlets should be located near each machine so power or extension cords are clear of high-traffic areas. Observe local electrical codes for proper installation of new lighting, outlets, or circuits.

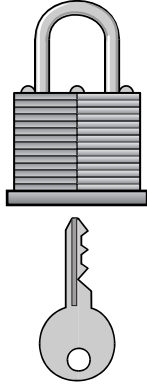
	<p>! WARNING</p> <p>Unsupervised children and visitors inside your shop could receive serious personal injury. Ensure child and visitor safety by keeping all entrances to the shop locked at all times. DO NOT allow unsupervised children or visitors in the shop at any time.</p>
--	--



SECTION 6: ADJUSTMENTS

General

This section will cover the basic adjustment instructions needed to begin operation. Complete the adjustments provided in this manual and then read the remaining portion of the manual before attempting any type of operation.

Your safety is important! Please follow the warnings below during this entire section:

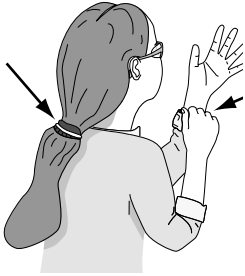
	<p>⚠ WARNING</p> <p>Loose hair and clothing could get caught in machinery and cause serious personal injury. Keep loose clothing rolled up and long hair tied up and away from machinery.</p>
--	--

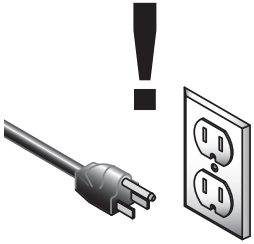
	<p>⚠ WARNING</p> <p>Serious personal injury could occur if you connect your machine to the power source before you have completed the assembly process. DO NOT connect the machine to the power source until instructed to do so.</p>
---	---

	<p>⚠ CAUTION</p> <p>Sharp edges on metal parts may cause personal injury. Examine the edges of all metal parts before handling.</p>
---	--



Table Tilt

When the table tilt is set to 0°, the table should be adjusted perpendicular to the sanding disc face.

To adjust table tilt:

1. Using a try square or machinist's square, set one edge on the table surface and the other against the face of the disc as shown in **Figure 3**. Note—*This can be done with the sandpaper installed, although it is somewhat easier to measure if the disc does not have the sandpaper disc installed.*
2. Loosen the lock lever and adjust the table angle until it is perfectly perpendicular.
3. Tighten the lock lever while holding the table perpendicular.
4. Adjust the stop bolt and tighten. Note—*Remove this bolt if you want to have the table angle less than 90°.*
5. Move the table angle and return it to the 0° point using the indicator, then recheck with the square to verify the setting.

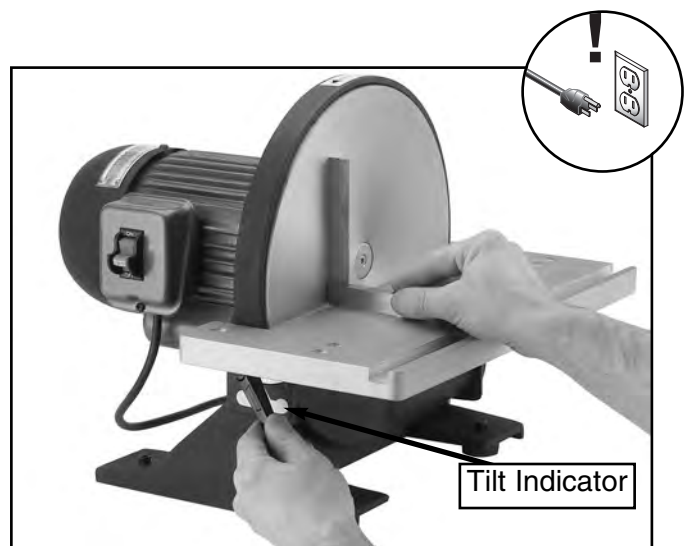

Figure 3. Squaring disc table.



Miter Gauge

The miter gauge needs to be adjusted perpendicular to the face of the wheel when it is mounted in the table slot.

To adjust miter gauge:

1. Use a try square or machinist's square with one edge against the face of the miter gauge and the other against the disc face as shown in **Figure 4**.
2. Loosen the adjusting screw on the miter gauge and adjust it flush with the edge of the square.
3. Tighten the gauge adjusting screw, and verify the setting. Note—*Sometimes the tightening procedure can affect the adjustment.*
4. Loosen the screw that secures the angle pointer and adjust the pointer to the 0° mark.
5. Retighten the screw that secures the angle pointer.

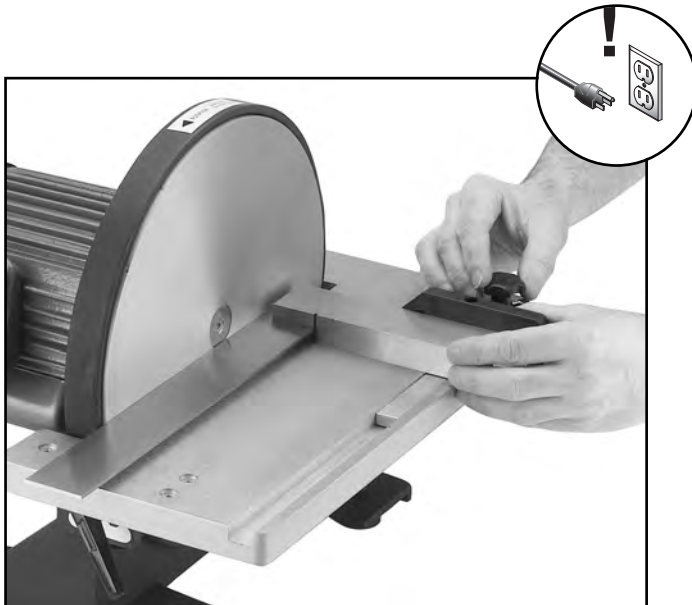

Figure 4. Squaring miter gauge to disc.



Attaching Sandpaper

The Model G7297 Disc Sander accepts 12" diameter cloth or paper-backed PSA sanding discs. These are available in a variety of grits. See the current Grizzly catalog for prices and ordering information.

The sanding disc sticks to the surface of the cast iron disc, using the pressure sensitive adhesive backing (PSA) on the reverse side of the sandpaper disc. The sandpaper can be replaced without removing either the table or the dust port.

To attach sandpaper:

1. Peel back the protective layer on **one-half** of the sandpaper disc and fold it against the remaining half.
2. Slip the half with the protective layer between the disc and the table edge (**Figure 5**).



Figure 5. Sandpaper being slipped between the disc and table.

3. Position the exposed adhesive on the upper half of the disc that extends above the table. Once it is positioned evenly across the disc, press the adhesive onto the surface.
4. Now rotate the disc so the lower half is now above the table.
5. Bend the paper back and remove the remaining half of the protective layer (**Figure 6**), and then press this portion against the disc.

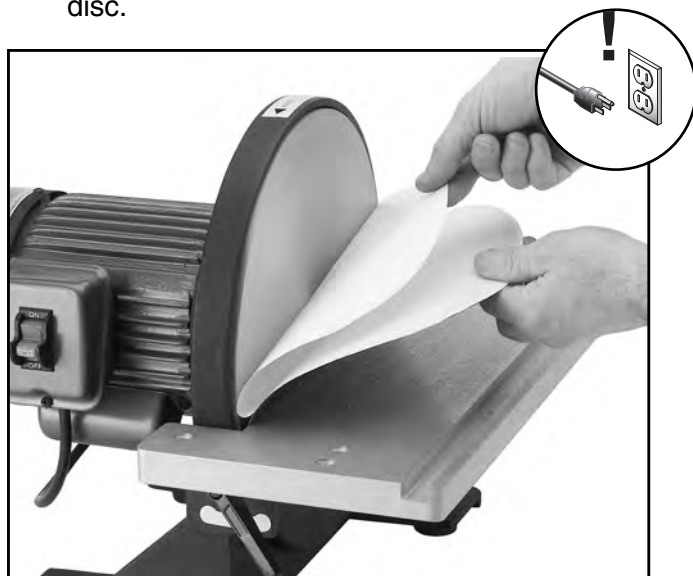

Figure 6. Removing protective layer.



Aligning Table

The table must be aligned to the face of the sanding disc so that the sandpaper does not rub against the table.

To align the table:

1. Loosen the screws that secure the table to the table support bracket.
2. Align the table so that there is a $\frac{1}{16}$ " gap between the 12" disc and the table (**Figure 7**).
3. Tighten the screws loosened in **step 1**.
4. Spin the disc by hand to check if the sandpaper is touching the table. Note—*DO NOT turn the disc sander on at this point.*
5. Repeat **steps 1-3** if sandpaper touches table at any point in the rotation.

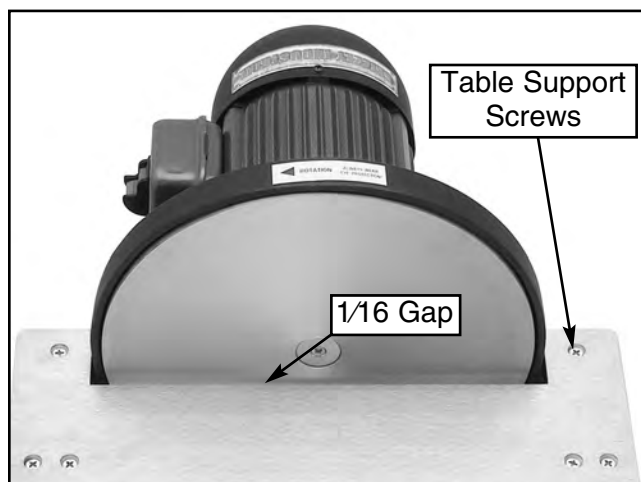

Figure 7. Table aligned with sanding disc.



SECTION 7: OPERATIONS

General

This section will cover basic disc sanding operations. Please read the remaining portion of the manual before attempting any type of operation.

Your safety is important! Please follow the warnings below during this entire section:

!WARNING

Damage to your eyes, lungs, and ears could result from failure to wear safety glasses, a dust mask, and hearing protection while sanding with this machine.

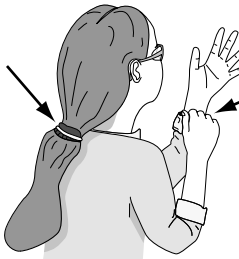
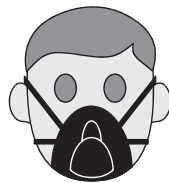

!WARNING

Loose hair and clothing could get caught in machinery and cause serious personal injury. Keep loose clothing rolled up and long hair tied up and away from machinery.

!WARNING

Operating this equipment has the potential to propel debris into the air which can cause eye injury. Always wear safety glasses or goggles when operating equipment. Everyday glasses or reading glasses only have impact resistant lenses, they are not safety glasses. Be certain the safety glasses you wear meet the appropriate standards of the American National Standards Institute (ANSI).

Disc Sanding

To perform sanding operations:

1. Set the angle of the table relative to the sanding disc. The angle can be set with the angle gauge on the disc sander or with a protractor for greater accuracy.
2. When a 90° horizontal angle is required, place one surface of the workpiece firmly against the face of the miter gauge (set at 0°), with the other surface against the face of the disc (**Figure 8**).

Note—For sanding curves or irregular shapes, remove the miter gauge from the disc table. Always keep the workpiece on the side of the wheel that is rotating down toward the table. This will keep the workpiece from flying out of your hands from the rotational forces.



Figure 8. Disc sanding.



Miter Sanding

The most efficient way to get a perfect miter is to cut the workpiece slightly long and sand it to the desired dimension. Miter sanding can be done easily with the miter gauge:

To perform miter sanding operations:

1. Loosen the knob on the miter gauge and adjust the angle to the desired point. Tighten the knob.
2. Slide the miter gauge into its slot and use it to hold your workpiece in position. Note—*The miter gauge can be used in either direction in the slot to achieve the proper relation of the workpiece to the disc.*
3. With light, but firm pressure, push the workpiece slowly into the downspin side of the rotating disc (**Figure 9**).

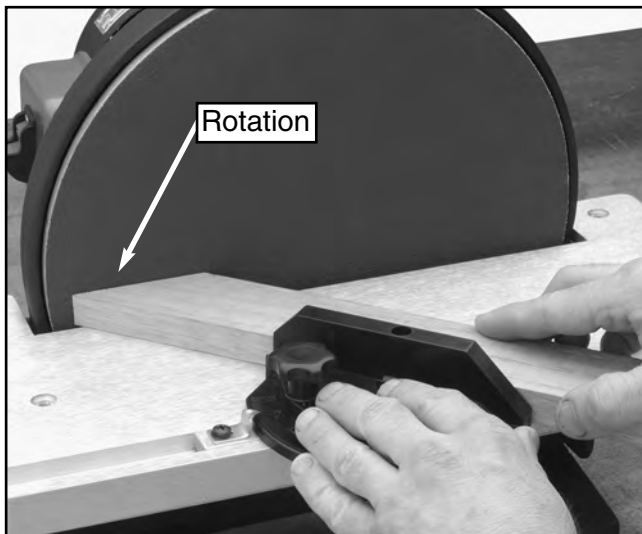

Figure 9. Mitering with gauge angled.



Angle Sanding

To perform angle sanding operations:

1. Loosen the handles securing the table.
2. Use the angle gauge to achieve the desired table angle and tighten the handles. Note—*The disc table can be positioned from -15° to 35° , relative to the plane of the sanding surface. Whenever possible, sand with an open angle where there is plenty of clearance between the disc and the table. This will avoid trapping the workpiece between the sanding surface and the table.*
3. Slide the miter gauge into its slot and use it to hold your workpiece in position.
4. With light, but firm pressure, push the workpiece slowly into the downspin side of the rotating disc (**Figure 10**).

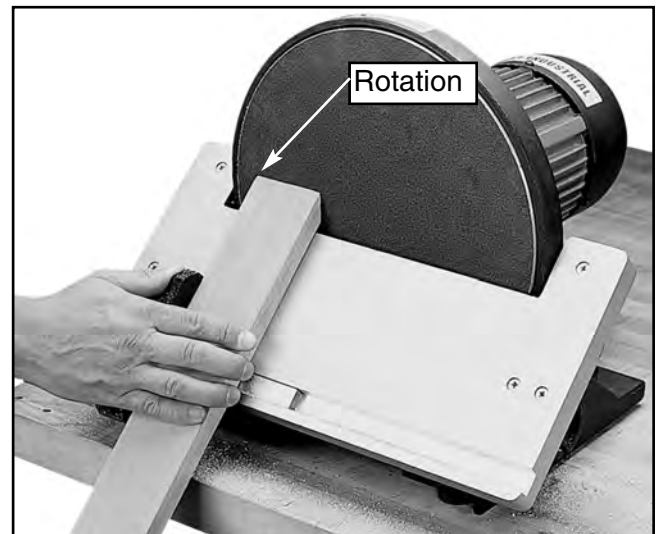

Figure 10. Mitering with table angled.





SECTION 8: MAINTENANCE

Maintenance Safety

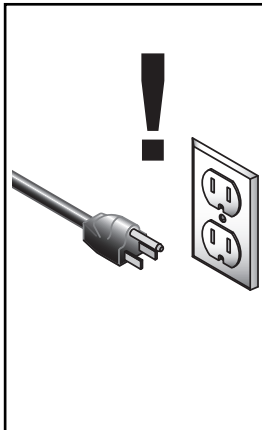
Your safety is important! Please follow the warnings below during this entire section:

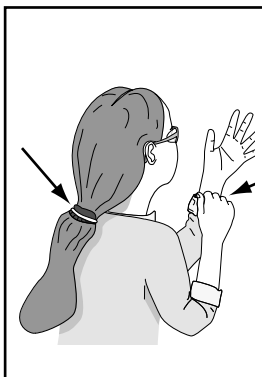
	<p>⚠️ WARNING Serious personal injury could occur if you connect your machine to the power source during the maintenance process. DO NOT connect the machine to the power source while performing any maintenance on this machine.</p>
---	--

	<p>⚠️ WARNING Loose hair and clothing could get caught in machinery and cause serious personal injury. Keep loose clothing rolled up and long hair tied up and away from machinery.</p>
--	--

	<p>⚠️ WARNING Projectiles from the machine could cause serious eye injury. Wear safety glasses at all times.</p>
---	---



Schedule

Following a maintenance schedule ensures that your machine is safe and performs accurately.

Check the following items before you use the disc sander:

- Loose mounting bolts.
- Worn loose, or damaged sanding disc.
- Worn or damaged wires.
- Any other condition that could hamper the safe operation of this machine.

Perform the following tasks at the scheduled time intervals:

After Each Use

- Wipe off the sawdust build-up from the table surface.

Weekly

- Wipe a lubricant such as SLIPIT® onto the table.

Long-Term Storage

- Keep unpainted surfaces rust free with products such as Boeshield® T-9.



SECTION 9: REFERENCE INFO

General

This section contains the following subsections for the Model G7297 Disc Sander: aftermarket accessories, data sheets, wiring diagrams, parts diagrams and list, troubleshooting, and warranty/return information.

If you need parts or help in assembling your machine, or if you need operational information, call the service department at (570) 546-9663. Trained service technicians will be glad to help you.



Aftermarket Accessories

The following aftermarket accessories can be ordered from the Grizzly Catalog by calling (800) 523-4777, or by visiting www.grizzly.com.

12" PSA Sanding Discs

MODEL	DESCRIPTION
G1220.....	60 Grit
G4255.....	80 Grit
G1221.....	100 Grit
G4256.....	120 Grit
G1222.....	150 Grit
G4257.....	100 Grit
G4258.....	220 Grit



TROUBLESHOOTING GUIDE

SYMPTOM	POSSIBLE CAUSE	CORRECTIVE ACTION
Motor will not start; fuses or circuit breakers blow.	<ol style="list-style-type: none"> 1. No voltage. 2. Incorrect fuses or circuit breakers in power line. 3. Bad wiring in motor, or faulty start capacitor. 4. Short circuit in line cord or plug. 	<ol style="list-style-type: none"> 1. Check for tripped fuse or breaker. 2. Install correct fuses or circuit breakers. 3. Inspect all connections on motor for loose or shorted terminals, replace start capacitor. 4. Inspect cord or plug for damaged insulation and shorted wires.
Motor fails to develop full power (power output of motor decreases rapidly with decrease in voltage at motor terminals).	<ol style="list-style-type: none"> 1. Circuit is overloaded. 2. Start capacitor is faulty 3. Undersized wires or circuits too long. 	<ol style="list-style-type: none"> 1. Reduce load on circuit, or use dedicated circuit. 2. Replace start capacitor. 3. Increase wire sizes or reduce length of wire.
Motor overheats, slows, or stalls (resulting in blown fuses or tripped circuit).	<ol style="list-style-type: none"> 1. Motor overloaded. 2. Air circulation through the motor restricted. 3. Short circuit in motor or loose connections. 4. Low voltage. 5. Incorrect fuses or circuit breakers in power line. 	<ol style="list-style-type: none"> 1. Reduce load on motor, feed workpiece slower 2. Clean out motor to provide normal air circulation. 3. Inspect connections on motor for loose or shorted terminals. 4. Correct the low voltage conditions. 5. Install correct fuses or circuit breakers.
Sanded surface not square.	<ol style="list-style-type: none"> 1. Table not perpendicular to disc. 2. Miter gauge not square to disc. 	<ol style="list-style-type: none"> 1. Adjust table tilt. 2. Adjust miter gauge.

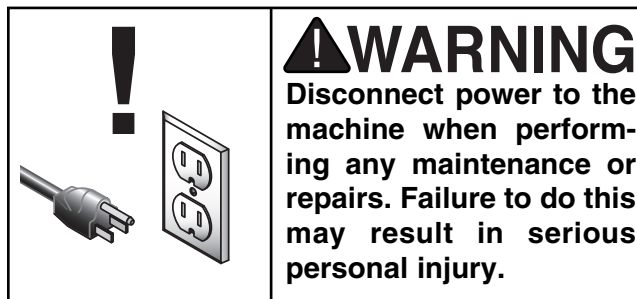



MACHINE DATA SHEET

Customer Service #: (570) 546-9663 • To Order Call: (800) 523-4777 • Fax #: (800) 438-5901

GRIZZLY MODEL G7297 12" DISC SANDER

Design Type..... Bench Model

Overall Dimensions and Specifications:

Height14½"
 Width17⅞"
 Length18"
 Table17¼" x 8¼"
 Weight66 lbs.
 Box Size.....18" L x 17" W x 17" H
 Footprint13" x 10"

Features:

Aluminum Disc.....12"
 Aluminum Disc Speed1750 RPM
 Miter Gauge Groove.....⅜" x ¼"
 Miter Gauge.....Plastic / Aluminum
 Table Tilt Range45°

Construction:

BaseCast Iron
 TableAluminum

Motor:

TypeTEFC Capacitor Start
 Horsepower.....1 HP
 Phase / VoltageSingle Phase / 110V
 Amperage10
 Cycle and RPM60 Hertz / 1750 RPM
 SwitchKeyed Safety Switch
 Power TransferDirect Drive
 BearingsSealed, Permanently Lubricated

Features:

.....2" Dust Port
Locking Miter Bar
Accepts 12" PSA Discs
Large Tilting Cast Aluminum Table

Specifications, while deemed accurate, are not guaranteed.

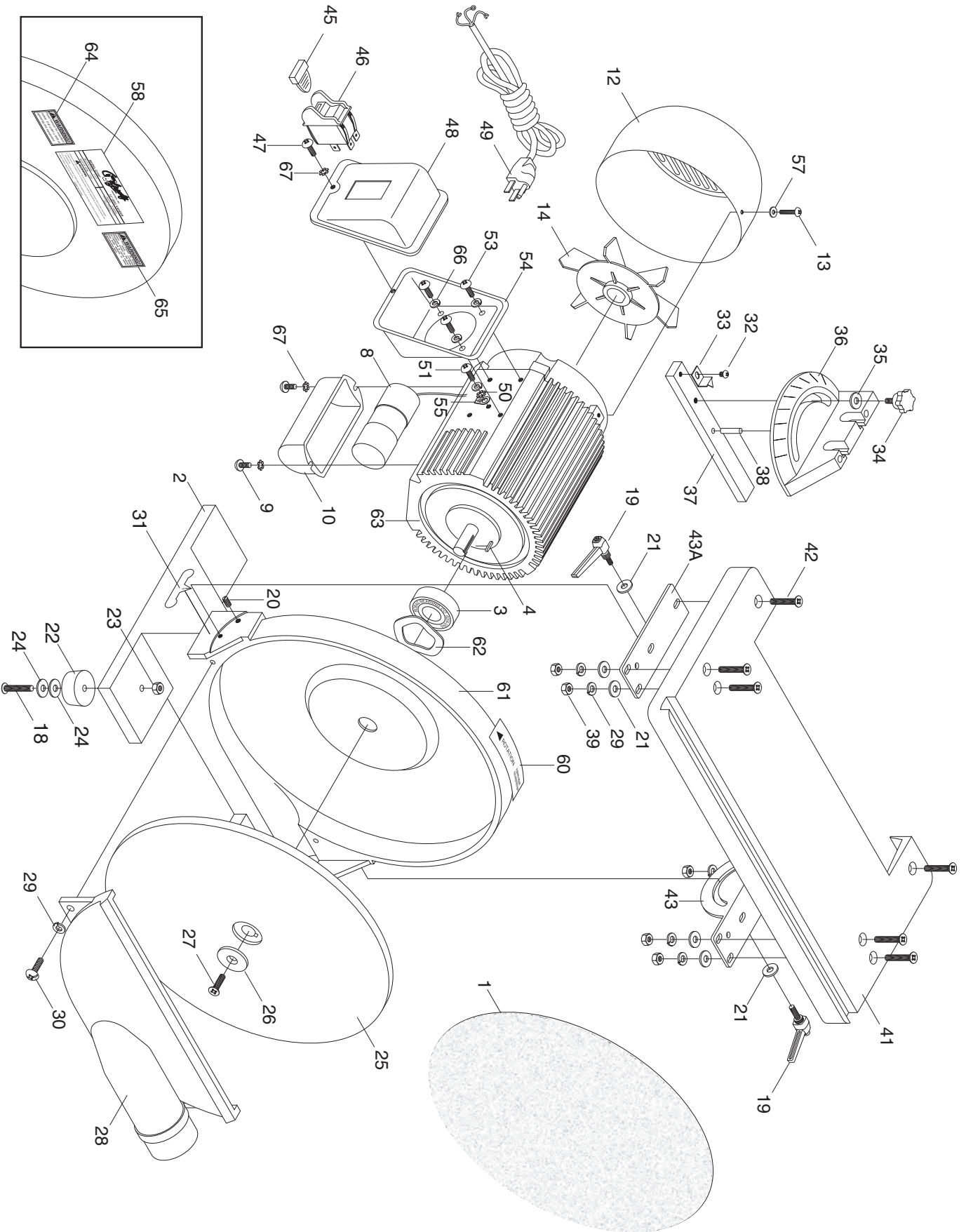

REF	PART #	DESCRIPTION
1	P7297001	SANDING DISC 80 GRIT
2	P7297002	BASE
3	P7297003	BEARING 6204
4	P7297004	KEY M5 X 5 X 25
8	P7297008	CAPACITOR 100MFD/250V
9	P7297009	PHLP HD SCR M4-0.7 X 8
10	P7297010	CAPACITOR COVER
12	P7297012	FAN COVER
13	P7297013	PHLP HD SCR M4-.7 x 6
14	P7297014	FAN
15	P7297015	PHLP HD SCR M5-.8 X 20
18	P7297018	PHLP HD SCR M6-1.0 X 25
19	P7297019	TABLE LOCK
20	P7297020	ADJUSTING PIN
21	P7297021	FLAT WASHER 6MM
22	P7297022	RUBBER PAD
23	P7297023	HEX NUT M6-1.0
24	P7297024	FLAT WASHER 6MM
25	P7297025	ALUMINUM SANDING DISC
26	P7297026	SPCL WASHER 1/4"ID X 1-1/4"OD
27	P7297027	PHLP HD SCR M6-1.0 X 20
28	P7297028	DUST CHUTE COVER
29	P7297029	LOCK WASHER 6MM
30	P7297030	PHLP HD SCR M6-1.0 X 20
31	P7297031	REFERENCE LABEL
32	P7297032	BUTTON HD CAP SCR M5-.8 X 6
33	P7297033	ANGLE POINTER
34	P7297034	KNOB BOLT M6-1 X 22
35	P7297035	FLAT WASHER 6MM

REF	PART #	DESCRIPTION
36	P7297036	MITER GAUGE
36A	P7297036A	COMPLETE MITER GAUGE
37	P7297037	GAUGE SLIDE
38	P7297038	ROLL PIN 5 X 12
39	P7297039	HEX NUT M6-1.0
41	P7297041	WORK TABLE
42	P7297042	FLAT HD SCR M6-1.0 X 20
43	P7297043	LEFT TRUNNION
43A	P7297043A	RIGHT TRUNNION
45	P7297045	SWITCH LOCK
46	P7297046	PLASTIC TOGGLE SWTCH 110/220V
47	P7297047	PHLP HD SCR M4-0.7 x 6
48	P7297048	SWITCH PLATE
49	P7297049	CORD & PLUG
50	P7297050	EXT TOOTH WSHR 5MM
51	P7297051	PHLP HD SCR M5-0.8 X 10
53	P7297053	PHLP HD SCR M5-0.8 X 10
54	P7297054	WIRING BOX
55	P7297055	GROUND INDICATOR
57	P7297057	FLAT WASHER 4MM
58	P7297058	NAME PLATE
60	P7297060	ROTATION ARROW
61	P7297061	BASE AND REAR DISC COVER
62	P7297062	WAVY WASHER 39MM
63	P7297063	MOTOR 1HP
64	P7297064	READ MANUAL LABEL
65	P7297065	DUST WARNING
66	P7297066	LOCK WASHER 5MM
67	P7297067	EXT TOOTH WASHER 4MM

Warranty and Returns

Grizzly Industrial, Inc. warrants every product it sells for a period of **1 year** to the original purchaser from the date of purchase. This warranty does not apply to defects due directly or indirectly to misuse, abuse, negligence, accidents, repairs or alterations or lack of maintenance. This is Grizzly's sole written warranty and any and all warranties that may be implied by law, including any merchantability or fitness, for any particular purpose, are hereby limited to the duration of this written warranty. We do not warrant or represent that the merchandise complies with the provisions of any law or acts unless the manufacturer so warrants. In no event shall Grizzly's liability under this warranty exceed the purchase price paid for the product and any legal actions brought against Grizzly shall be tried in the State of Washington, County of Whatcom.

We shall in no event be liable for death, injuries to persons or property or for incidental, contingent, special, or consequential damages arising from the use of our products.

To take advantage of this warranty, contact us by mail or phone and give us all the details. We will then issue you a "Return Number," which must be clearly posted on the outside as well as the inside of the carton. We will not accept any item back without this number. Proof of purchase must accompany the merchandise.

The manufacturers reserve the right to change specifications at any time because they constantly strive to achieve better quality equipment. We make every effort to ensure that our products meet high quality and durability standards and we hope you never need to use this warranty.

Please feel free to write or call us if you have any questions about the machine or the manual.

Thank you again for your business and continued support. We hope to serve you again soon.

WARRANTY CARD

Name _____
Street _____
City _____ State _____ Zip _____
Phone Number _____ E-Mail _____ FAX _____
MODEL # _____ Serial # _____ Order # _____

The following information is given on a voluntary basis. It will be used for marketing purposes to help us develop better products and services. Of course, all information is strictly confidential.

1. How did you learn about us?
 Advertisement Friend
 Catalog Card Deck
 World Wide Web
 Other _____
2. Which of the following magazines do you subscribe to.
 American Woodworker Practical Homeowner
 Cabinetmaker Shop Notes
 Family Handyman Today's Homeowner
 Fine Homebuilding WOOD
 Fine Woodworking Wooden Boat
 Home Handyman Woodshop News
 Journal of Light Construction Woodsmith
 Old House Journal Woodwork
 Popular Mechanics Woodworker
 Popular Science Woodworker's Journal
 Popular Woodworking Workbench
 Other _____
3. Which of the following woodworking/remodeling shows do you watch?
 Backyard America The New Yankee Workshop
 Home Time This Old House
 The American Woodworker Woodwright's Shop
 Other _____
4. What is your annual household income?
 \$20,000-\$29,999 \$60,000-\$69,999
 \$30,000-\$39,999 \$70,000-\$79,999
 \$40,000-\$49,999 \$80,000-\$89,999
 \$50,000-\$59,999 \$90,000 +
5. What is your age group?
 20-29 50-59
 30-39 60-69
 40-49 70 +
6. How long have you been a woodworker?
 0 - 2 Years 8 - 20 Years
 2 - 8 Years 20+ Years
7. How would you rank your woodworking skills?
 Simple Advanced
 Intermediate Master Craftsman
8. What stationary woodworking tools do you own? Check all that apply.
 Air Compressor Panel Saw
 Bandsaw Planer
 Drill Press Power Feeder
 Drum Sander Radial Arm Saw
 Dust Collector Shaper
 Horizontal Boring Machine Spindle Sander
 Jointer Table Saw
 Lathe Vacuum Veneer Press
 Mortiser Wide Belt Sander
 Other _____
9. How many of your woodworking machines are Grizzly? _____
10. Which benchtop tools do you own? Check all that apply.
 1" x 42" Belt Sander 6" - 8" Grinder
 5" - 8" Drill Press Mini Lathe
 8" Table Saw 10" - 12" Thickness Planer
 8" - 10" Bandsaw Scroll Saw
 Disc/Belt Sander Spindle/Belt Sander
 Mini Jointer
 Other _____
11. How many of the machines checked above are Grizzly? _____
12. Which portable/hand held power tools do you own? Check all that apply.
 Belt Sander Orbital Sander
 Biscuit Joiner Palm Sander
 Circular Saw Portable Planer
 Detail Sander Saber Saw
 Drill/Driver Reciprocating Saw
 Miter Saw Router
 Other _____
13. What machines/supplies would you like Grizzly Industrial to carry?

14. What new accessories would you like Grizzly Industrial to carry?

15. What other companies do you purchase your tools and supplies from?

16. Do you think your purchase represents good value?
 Yes No
17. Would you recommend Grizzly Industrial to a friend?
 Yes No
18. Would you allow us to use your name as a reference for Grizzly customers in your area? **Note: We never use names more than three times.**
 Yes No
19. Comments: _____

CUT ALONG DOTTED LINE

FOLD ALONG DOTTED LINE



Place
Stamp
Here



GRIZZLY INDUSTRIAL, INC.
P.O. BOX 2069
BELLINGHAM, WA 98227-2069



FOLD ALONG DOTTED LINE

Send a Grizzly Catalog to a friend:

Name _____
Street _____
City _____ State _____ Zip _____

TAPE ALONG EDGES--PLEASE DO NOT STAPLE

grizzly.com

TOOL WEBSITE

Buy Direct and Save with Grizzly® – Trusted, Proven and a Great Value!

*Visit Our Website Today And Discover Why
Grizzly® Is The Industry Leader!*

- SECURE ORDERING
- ORDERS SHIPPED WITHIN 24 HOURS
- E-MAIL RESPONSE WITHIN ONE HOUR

-OR-

Call Today For A **FREE**
Full Color Catalog

1-800-523-4777

