

Grizzly

Industrial, Inc.®

TOOL BOXES AND ROLLER CABINETS

Please read these instructions carefully

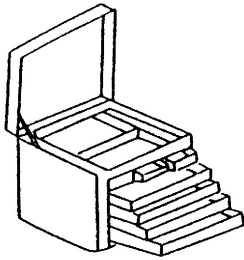

Tool Boxes

Boxes that have no front locking panel are equipped with a locking mechanism actuated by the lid. When the lid is closed, tabs in the lock bar engage the pockets on the drawers. When the lid is open, the tabs are raised clear of the pockets.

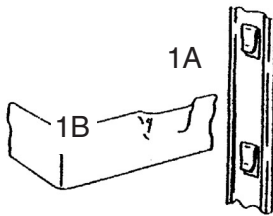

Important: The drawer must be fully closed before the lid is shut. **DO NOT** slam the drawers when the lid is shut; they will not lock and damage to lock bar tabs or lock pockets may occur. Should this happen, remove the drawer and straighten out the deformed tab with a screwdriver. For the lock pockets, a pair of pliers should be used. See (1A) lock bar tab and (1B) lock pocket.

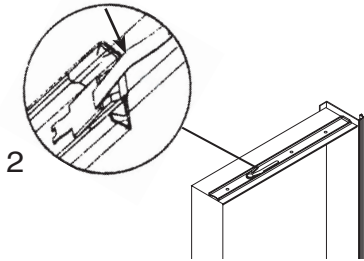

Removal/Re-installation of Drawers:

- To remove, pull drawer fully open. Push in the plastic tabs (2) on both sides to release drawer from slides. Pull the drawer out.
- To re-install, line up the drawer slides, engage, and close the drawer completely.

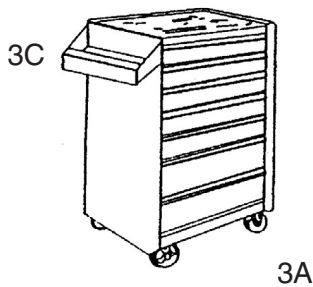

Roller Cabinets

The roller cabinets feature a rotating cam lock mechanism controlled by a key. When locked, hooks engage in each drawer to prevent them from being opened. When unlocked, the hooks disengage, allowing the drawers to be opened. If the cabinet is locked while the drawers are still open, simply close the drawers to lock them.

3B

Casters and Side Tray: Use the included screws to attach the two heavy-duty fixed casters (3A) and two heavy-duty swivel casters with brakes (3B) as shown in the diagram. The side handle/tool tray (3C) must be attached to the same side as the swivel casters.

4

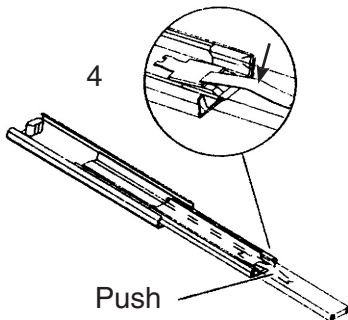

Push

Removal/Re-installation of Drawers:

- To remove, pull drawer fully open. Push in the plastic tabs (4) on both sides to release drawer from the slides. Pull the drawer out.
- To re-install, line up the drawer slides, engage, and close the drawer completely.

Lubrication

To ensure smooth operation of the slides, lubricate them periodically with a light grease or petroleum jelly. Do this at least twice a year or more, depending on the frequency of use.

