

Grizzly *Industrial, Inc.*®

4-Jaw Self-Centering Chuck for Wood Lathes

**MODEL H6264, H6265, H6266, H6267, H7820
INSTRUCTION SHEET**

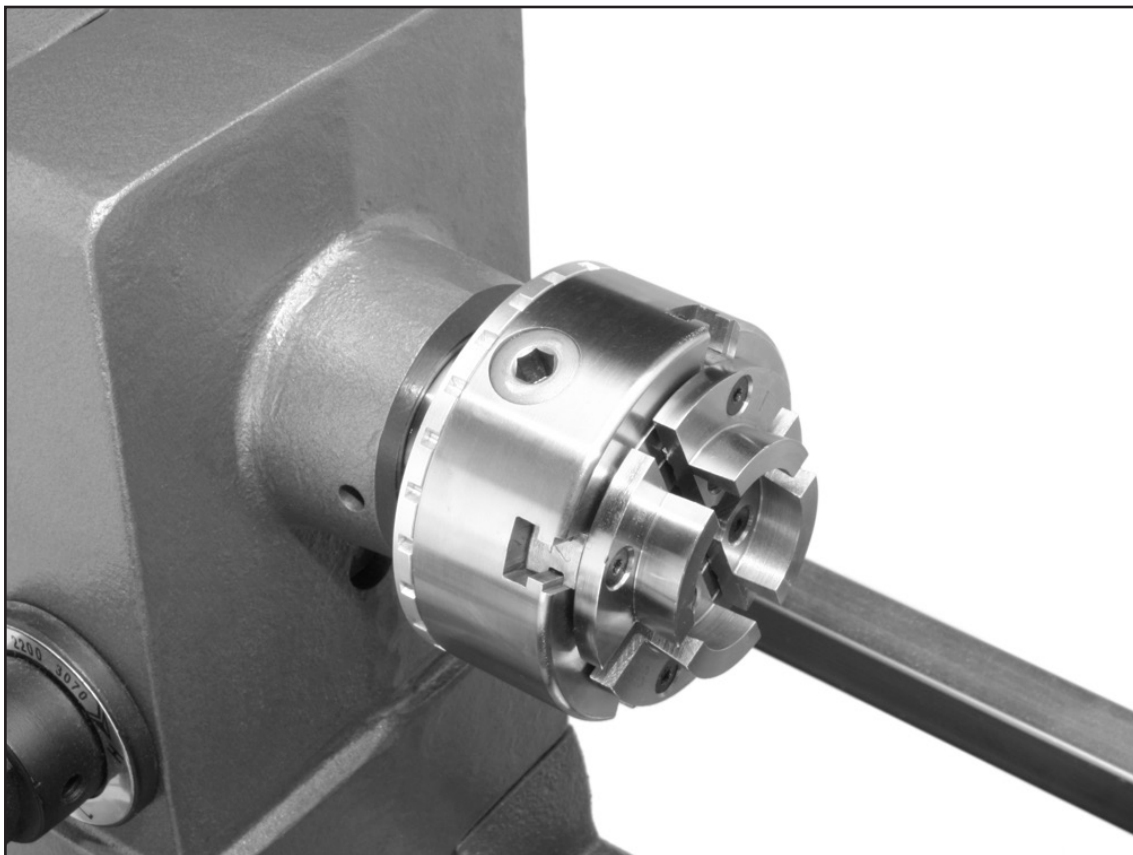

COPYRIGHT © AUGUST, 2004 BY GRIZZLY INDUSTRIAL, INC., REVISED DECEMBER, 2020 (JL)
WARNING: NO PORTION OF THIS MANUAL MAY BE REPRODUCED IN ANY SHAPE
OR FORM WITHOUT THE WRITTEN APPROVAL OF GRIZZLY INDUSTRIAL, INC.
#BL6507 PRINTED IN CHINA

PARTS INVENTORY

The Model H6264, H6265, H6266, H6267, H7820 was carefully packed when it left our warehouse. If you discover this chuck is damaged after you have signed for delivery, *please immediately call Customer Service at (570) 546-9663 for advice.*

Save the containers and all packing materials for possible inspection by the carrier or its agent. *Otherwise, filing a freight claim can be difficult.*

When you are completely satisfied with the condition of your shipment, you should inventory the contents.

Figure 1 - Main Contents.

- A. 4-Jaw Self-Centering Chuck 1
- B. Wood Screw 1
- C. T-handle hex wrench, 3mm..... 1
- D. T-handle hex wrench, 8mm..... 1

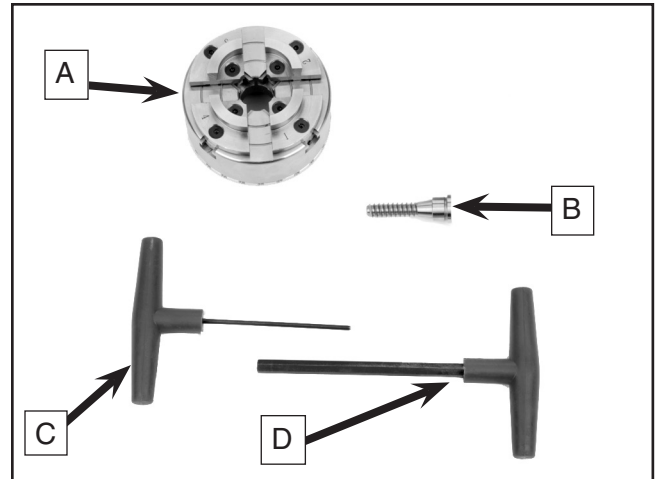

Figure 1. Main contents.

! WARNING

Children may climb into plastic bags and suffocate. Keep all plastic bags included in packaging out of the reach of children.

! CAUTION

Follow all safety procedures for woodworking when using this chuck.

OPERATION INSTRUCTIONS

This chuck's compact size makes it ideal for use on 12" (300 mm) capacity lathes and smaller. The jaws are configured for both outside diameter (O.D.) and inside diameter (I.D.) gripping. The minimum gripping O.D. is 1.25", and the minimum gripping I.D. is 1.8".

Opening/Closing Jaws

1. With the chuck mounted on the lathe, open/close the chuck jaws so that the workpiece can be placed between the jaws (**Figure 3**).
2. Insert the workpiece between the jaws. Be sure that the workpiece is seated against the jaw face.
3. Close/open the chuck jaws to securely clamp the workpiece.
4. To remove the workpiece from the chuck, open/close jaws until the workpiece is free.

Wood Screw Use

This chuck is supplied with a wood screw for use with small, cross-grained pieces.

1. Drill a 7-8 mm diameter hole that is 25 mm deep, in the center of the workpiece.
2. Make sure the workpiece is as round as possible.
3. Mount the wood screw in the chuck with the shoulder of the wood screw clamped between the backing jaws (**Figure 4**).
4. Screw the workpiece onto the wood screw until it is firmly against the jaws.
5. Unscrew workpiece once machining is completed.

Chuck Maintenance

To maintain the chuck, spray oil into the scroll and work the jaws through their full range of motion. Do this on a daily basis.

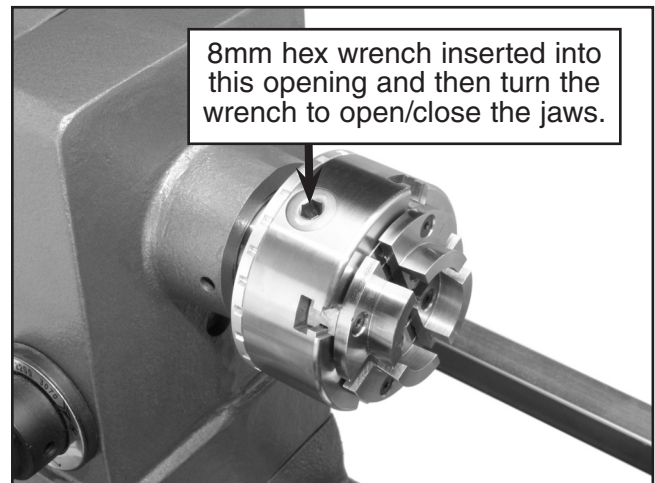

Figure 2. Chuck Operation.

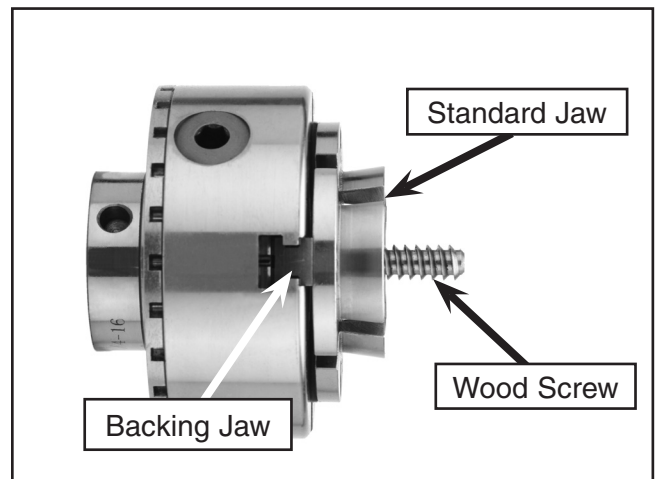

Figure 3. Wood Screw Placement.

Check the chuck for dust build-up in the scrolls and jaws and clean as required.

To remove the jaws and backing jaws, the stop pin will need to be removed from the slot of jaw #4. By doing this, the jaws will be able to travel beyond the scroll and then they can be pulled out of the slots.

To install jaws, first make sure you have jaw #1 going into slot #1 and so on, then turn scroll until all jaws have engaged. Continue turning scroll until the pin hole in slot #4 is visible and then reinsert the stop pin.

H6264, H6265, H6266, H6267, H7820 Parts Breakdown and List

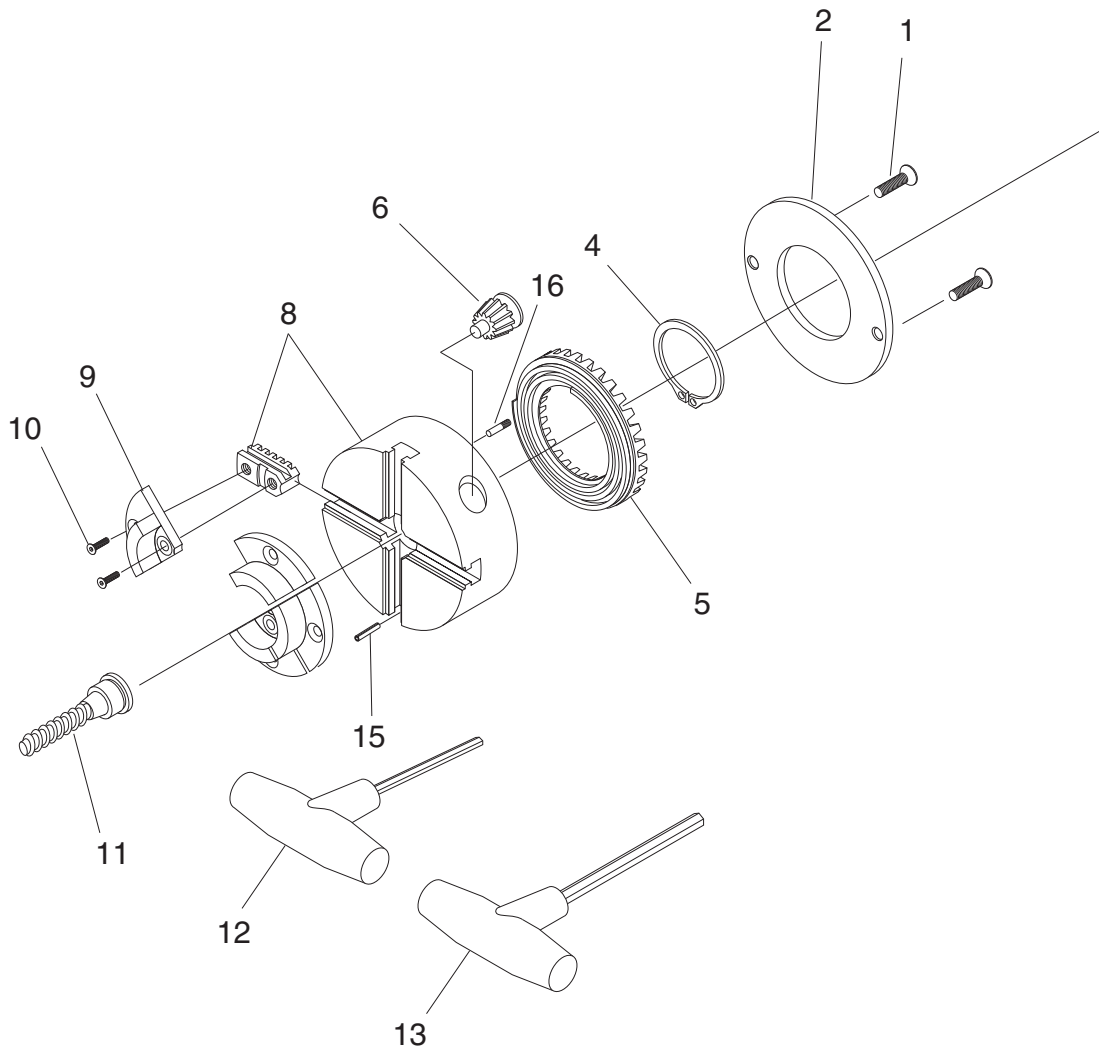

REF	PART #	DESCRIPTION
1	PFH31M	FLAT HD SCR M4-.7 X 8
2	PH6264002	BACKING PLATE
4	PR43M	EXT RETAINING RING 50MM
5	PH6264005	SCROLL RING
6	PH6264006	PINION
8	PH6264008	BACKING JAWS W/CHUCK BODY
9	PH6264009	CHUCK JAWS (QTY 4)

REF	PART #	DESCRIPTION
10	PH6266010	TAPER HEAD SCREW M5-.8 X 12
11	PH6264011	WOOD SCREW (SPECIAL)
12	PH6264012	T-HANDLE HEX WRENCH 3MM
13	PH6264013	T-HANDLE HEX WRENCH 8MM
15	PH6264015	STOP PIN
16	PH6264016	LOCK PIN M5-.8 X 6 X 20