

# *Grizzly* Industrial, Inc.®

## MODEL H6330 2¼ GALLON PAINT TANK INSTRUCTION MANUAL



COPYRIGHT © MAY, 2008 BY GRIZZLY INDUSTRIAL, INC. REVISED JUNE, 2012 (TR)  
**WARNING: NO PORTION OF THIS MANUAL MAY BE REPRODUCED IN ANY SHAPE  
OR FORM WITHOUT THE WRITTEN APPROVAL OF GRIZZLY INDUSTRIAL, INC.**

#JM10748 PRINTED IN CHINA



## **WARNING!**

This manual provides critical safety instructions on the proper setup, operation, maintenance, and service of this machine/tool. Save this document, refer to it often, and use it to instruct other operators.

Failure to read, understand and follow the instructions in this manual may result in fire or serious personal injury—including amputation, electrocution, or death.

The owner of this machine/tool is solely responsible for its safe use. This responsibility includes but is not limited to proper installation in a safe environment, personnel training and usage authorization, proper inspection and maintenance, manual availability and comprehension, application of safety devices, cutting/sanding/grinding tool integrity, and the usage of personal protective equipment.

The manufacturer will not be held liable for injury or property damage from negligence, improper training, machine modifications or misuse.



## **WARNING!**

Some dust created by power sanding, sawing, grinding, drilling, and other construction activities contains chemicals known to the State of California to cause cancer, birth defects or other reproductive harm. Some examples of these chemicals are:

- Lead from lead-based paints.
- Crystalline silica from bricks, cement and other masonry products.
- Arsenic and chromium from chemically-treated lumber.

Your risk from these exposures varies, depending on how often you do this type of work. To reduce your exposure to these chemicals: Work in a well ventilated area, and work with approved safety equipment, such as those dust masks that are specially designed to filter out microscopic particles.

# SAFETY

## **WARNING**

### **For Your Own Safety Read Instruction Manual Before Operating This Equipment**

The purpose of safety symbols is to attract your attention to possible hazardous conditions. This manual uses a series of symbols and signal words which are intended to convey the level of importance of the safety messages. The progression of symbols is described below. Remember that safety messages by themselves do not eliminate danger and are not a substitute for proper accident prevention measures.



Indicates an imminently hazardous situation which, if not avoided, **WILL** result in death or serious injury.



Indicates a potentially hazardous situation which, if not avoided, **COULD** result in death or serious injury.



Indicates a potentially hazardous situation which, if not avoided, **MAY** result in minor or moderate injury. It may also be used to alert against unsafe practices.

**NOTICE**

This symbol is used to alert the user to useful information about proper operation of the equipment.

## **WARNING**

### **Safety Instructions for Pneumatic Tools**

- 1. READ THIS MANUAL.** This tool may cause personal injury if used incorrectly. This manual contains proper safety and operating instructions that must be followed to reduce this risk.
- 2. WEAR EYE PROTECTION.** This tool may throw small fragments during operation, which may cause serious eye injury. Always wear ANSI approved safety glasses or face shield to reduce your risk from this hazard.
- 3. WEAR A RESPIRATOR.** This tool may produce fine dust during operation, which can cause respiratory injury if inhaled. Always wear a respirator NIOSH approved for the type of material being processed.
- 4. WEAR HEARING PROTECTION.** Operating this tool for prolonged time periods may damage your hearing. Your risk depends on length and frequency of use. To reduce your risk of this hazard, wear hearing protection.
- 5. MAINTAIN SAFETY GUARDS.** Your tool may be equipped with safety guards or other structural components designed to reduce the risk of injury during operation. Never modify or operate this tool with any guards or components removed or damaged.
- 6. KEEP CHILDREN AWAY.** Prevent children from injury by keeping them away from this tool. Disconnect and lock the tool away when not in use.

7. **AVOID ENTANGLEMENTS.** Do not wear loose clothing, gloves, neckties, rings, bracelets, or other jewelry, which may get caught in moving parts, when operating this tool. Wear a protective hair covering to contain long hair.
8. **USE CORRECT AIR PRESSURE.** Exceeding the maximum PSI rating of this tool may cause unpredictable operation or bursting.
9. **DISCONNECT AIR PRESSURE** before servicing, changing accessories, or moving to another location. Never leave this tool unattended when connected to air.
10. **SECURE TOOLING.** Always verify tooling is secure before operation.
11. **SHARP SURFACES.** DO NOT place hands near the tooling surfaces when in operation.
12. **REMOVE ADJUSTING KEYS AND WRENCHES AFTER USE.** These tools become dangerous projectiles if left on the tool when it is started.
13. **AVOID FLAMMABLES.** Do not use this tool around any flammables that may be ignited by sparks.
14. **SECURE WORK.** Use clamps or a vise to hold work when practical. It is safer than using your hand and frees both hands to operate tool.
15. **MAINTAIN TOOLS WITH CARE.** Keep tools lubricated and clean for best and safest performance. Follow instructions for lubricating and changing accessories.
16. **DO NOT FORCE TOOL.** It will do the job better and safer at the rate for which it was designed.
17. **CHECK FOR DAMAGED PARTS BEFORE USING.** Check for binding and alignment of parts, broken parts, part mounting, loose bolts, and any other conditions that may affect operation. Repair or replace damaged parts before operating.
18. **USE GOOD LIGHTING.** Keep work area well lighted. Dark work areas increase risk of accidental injury.
19. **AVOID UNINTENTIONAL OPERATION.** Always disconnect air when not in use, and do not carry tool with hand on trigger.
20. **USE THE RECOMMENDED ACCESSORIES.** Consult owner's manual for recommended accessories. Using improper accessories may increase the risk of injury.
21. **NEVER ALLOW UNTRAINED USERS TO USE THIS TOOL WHILE UNSUPERVISED.**
22. **IF YOU ARE UNSURE OF THE INTENDED OPERATION, STOP USING TOOL.** Seek formal training or research books or magazines that specialize in pneumatic tools.
23. **BE AWARE OF HOSE LOCATION.** Hoses can easily become a tripping hazard when laid across the floor in a disorganized fashion.
24. **DO NOT USE UNDER THE INFLUENCE OF DRUGS OR ALCOHOL, OR WHEN TIRED.**

# WARNING

## Additional Safety Instructions for Paint Tanks

- 1. READ THIS MANUAL.** This manual contains proper operating instructions for this paint tank.
- 2. DESIGN MODIFICATIONS.** Do not modify the tank design or construction. Drilling into the tank or weld attachments, or altering its design, could weaken the tank.
- 3. CLEANING AND MAINTENANCE.** Clean and dry the tank and lid according to the instructions in this manual. Make sure all ports are free of hardened paint or other materials that could prevent free movement of air. Improper cleaning could allow pressure to rise to dangerous levels.
- 4. REACTIVE CHEMICALS.** Do not use acids, caustic solutions, or halogenated hydrocarbon solvents. These chemicals can attack the lid gasket and safety valve seal, compromising the ability of the tank to hold pressure.
- 5. SAFETY VALVE MODIFICATIONS.** Never adjust the safety valve to change its pressure setting or defeat its function. Tampering with the safety valve could allow tank pressure to rise to dangerous levels.
- 6. REMOVING LID.** Do not try to remove the lid while the tank is under pressure, or the lid could explode from the tank. Follow the instructions in this manual for relieving pressure in the tank before removing the lid.
- 7. LID CLAMPS.** Overtightening the lid clamps could cause them to weaken and fail, resulting in the lid exploding violently from the tank. Only tighten the clamps by hand. Do not use tools to tighten them.
- 8. NON-STANDARD COMPONENTS.** Substituting non-standard components could weaken the tank or cause component failure. Only use components provided with your tank.
- 9. ATTACHMENTS.** Make sure equipment connected to the tank has a higher pressure rating than the regulated air pressure in the tank. Attachments with a pressure rating lower than the adjusted tank pressure could explode, resulting in serious personal injury.

# CAUTION

No list of safety guidelines is complete, because every work environment is different. Always consider safety first and use common sense. Failure to use this tool with caution and respect could result in serious personal injury.

# INTRODUCTION

---

---

## Foreword

---

---

The specifications, details, and photographs in this manual represent the Model H6330 as supplied when the manual was prepared. However, owing to Grizzly's policy of continuous improvement, changes may be made at any time with no obligation on the part of Grizzly.

If you have any comments regarding this manual, please write to us at the following address:

Grizzly Industrial, Inc.  
C/O Technical Documentation  
P.O. Box 2069  
Bellingham, WA 98227-2069  
E-Mail: manuals@grizzly.com

Most importantly, we stand behind our tools. If you have any service questions or parts requests, please call or write us at the location listed below.

Grizzly Industrial, Inc.  
1203 Lycoming Mall Circle  
Muncy, PA 17756  
Phone: (570) 546-9663  
Fax: (800) 438-5901  
E-Mail: techsupport@grizzly.com  
Web Site: <http://www.grizzly.com>

## Specifications

---

---

### Paint Tank

Material Capacity .....2¼ Gallons (8.5 L)  
Operating Pressure .....25–30 PSI  
Maximum Operating Pressure .....45 PSI  
Tank Construction ..... Galvanized Steel

**⚠ WARNING**

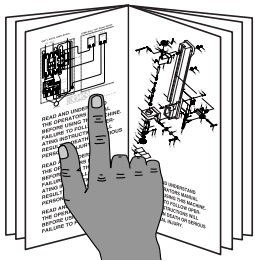

**Read the manual before operation. Become familiar with this paint tank, its safety instructions, and its operation before beginning any work. Serious personal injury may result if safety or operational information is not understood or followed.**

# SETUP

## Unpacking

Your paint tank was carefully packaged for safe shipping. If you discover any damage after you have signed for delivery, *immediately call Customer Service at (570) 546-9663 for advice.*

Save the containers and all packing materials for possible inspection by the carrier or its agent. *Otherwise, filing a freight claim can be difficult.*

When you are completely satisfied with the condition of the shipment, you should inventory the contents.

## Inventory

H6330 Inventory (Figure 1).....	Qty
A. Paint Tank 2¼ Gallon.....	1
B. Lid.....	1
C. Regulator Assembly.....	1
D. Lift Handle.....	1

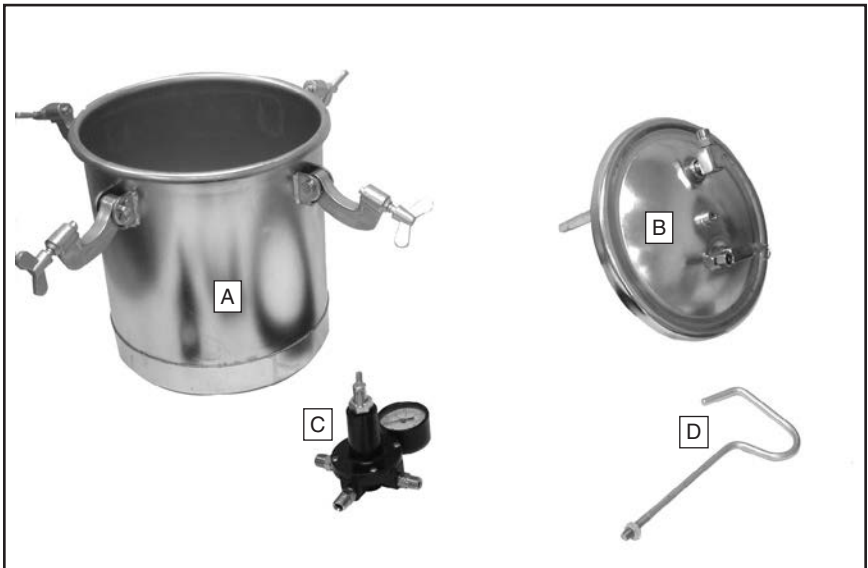
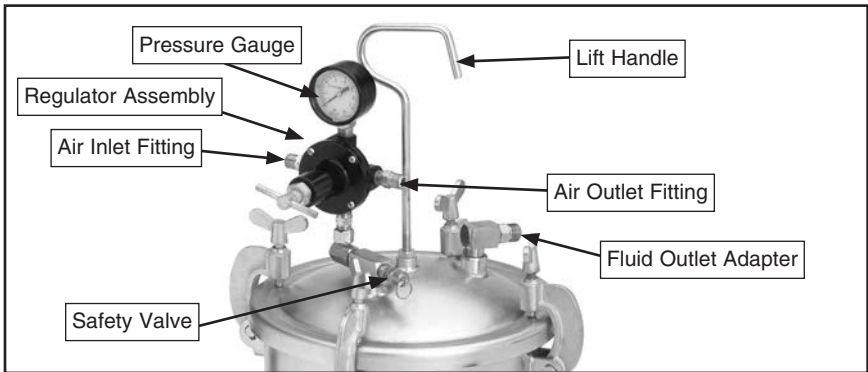

Figure 1. Model H6330 Inventory.

# Tank Assembly



**Figure 2.** Regulator and lift handle installed on paint tank.

## To assemble the paint tank:

1. Apply pipe thread tape to all male pipe threads.
2. Thread the lift handle into the center hole on the tank lid (see **Figure 2**) and secure with the hex nut.
3. Thread the regulator assembly onto the swivel adapter on the lid, as shown in **Figure 2**.
4. Connect a 1/4" NPT air supply hose (not included) to the inlet fitting on the regulator.
5. Connect a 1/4" NPT air supply hose (not included) to the air outlet fitting on the opposite side of the regulator.
6. Connect a 1/4" NPT material hose (not included) to the fluid outlet adapter on the tank lid.
7. Install a pressure regulator (not included), between the tank regulator, (**Figure 3**) and the spray gun, since some of the pressurized air from the compressor will bypass the tank regulator.

**Figure 3** depicts the paint tank connected to a compressed air system with a filter/regulator unit and a spray gun.

The filter/regulator unit protects your tool from damaging water build-up, and allows you to adjust and maintain regulated air pressure. If you plan on installing a filter/regulator unit in your compressed air system, follow the connection instructions with the unit.

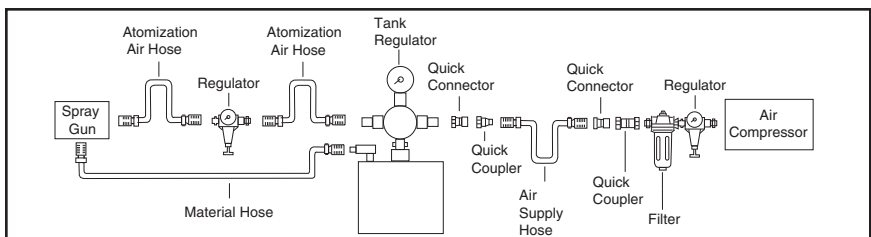

**Figure 3.** Paint tank connect to air compressor and spray gun.



# OPERATIONS

## Tank Regulator

The pressure regulator on the paint tank controls the amount of pressure in the paint tank and the spray gun.

The following are operating guidelines for internal and external spray guns:

**Internal Mix Guns:** Use higher tank pressures up to the full amount of air pressure being delivered to the spray gun. However, do not exceed 45 PSI at the spray gun or in the paint tank.

**External Mix Guns:** Use lower tank pressures—approximately 12 PSI for most external mix guns. Start with the tank at "zero" pressure and increase pressure gradually until the correct spray pattern is achieved.

**! DANGER**



**EXPLOSION HAZARD! DO NOT smoke or have any source of flame or spark near spraying. Vapors will explode if ignited.**

**! WARNING**

**Do not exceed the 45 PSI maximum operating pressure on your paint tank. Exceeding the maximum pressure may cause the tank to explode, causing serious personal injury.**

**! WARNING**



**RESPIRATORY HAZARD! Always use a NIOSH approved respirator when using spray equipment. Failure to protect your lungs can lead to respiratory illness and nervous system damage. Spraying some paints and varnishes may require a supplied air respirator system.**

**! WARNING**



**TOXIC FUMES! Always use an approved spray booth or well ventilated area when spraying. NEVER spray in an confined space where toxic fumes and flammable vapors can accumulate to deadly levels.**

**NOTICE**

**This paint tank is not designed for use with highly abrasive, corrosive, or rust inducing materials. If such materials are used, frequently and thoroughly clean all components to reduce the need to replace parts.**

## **!WARNING**

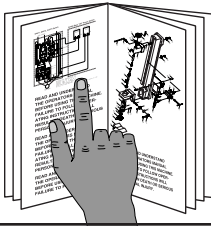

**Read the manual before operation. Become familiar with this tool, its safety instructions, and its operation before beginning any work. Serious personal injury may result if safety or operational information is not understood or followed.**

## **!WARNING**

**Like all tools there is potential danger when operating this tool. Accidents are frequently caused by lack of familiarity or failure to pay attention. If normal safety precautions are overlooked or ignored, serious personal injury may occur.**

## **Tank Setup**

---

---

### **To use your paint tank:**

1. Thoroughly mix and strain your paint to remove undissolved particles that could block the flow of material to the gun.
2. Pour paint into the tank; or set a one gallon can of paint in the tank, making sure the lid's fluid tube is seated in the can.

3. Place the lid assembly on the tank and evenly hand tighten the lid clamp wing screws.
4. Adjust the regulator at your air compressor to 45 PSI.
5. Fully turn the regulator T-handle counterclockwise to shut the tank regulator **OFF**.

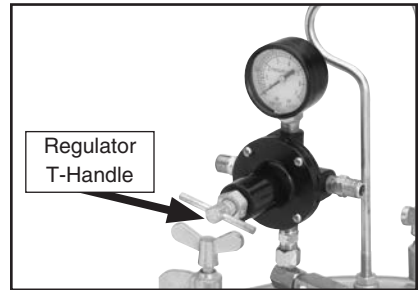

**Figure 4.** Regulator T-handle.

6. Connect the paint tank to the air compressor.
7. Adjust the paint tank to 25 PSI on the tank pressure gauge. Normal operating pressure is 25-30 PSI. Using trial and error, adjust the paint tank as necessary between this range for optimum results.

# CLEANING AND LUBRICATION

## Cleaning the Tank

Proper cleaning is the best way to ensure trouble free performance from your paint tank. If your tank is not thoroughly cleaned, damage and poor operation will result. Problems caused by improper cleaning will not be covered by the warranty. Clean the tank immediately after each use.

### To clean your paint tank:

1. DISCONNECT THE AIR SUPPLY FROM THE TANK!

### **!WARNING**

**EXPLOSION HAZARD! Removing the lid while the tank is pressurized could result in lid being thrown violently from tank, causing serious personal injury. Always shut off air pressure at source and bleed off all pressure in tank before removing lid.**

2. Bleed out all tank pressure by pulling the ring on the safety valve (**Figure 4**) until air stops hissing out.

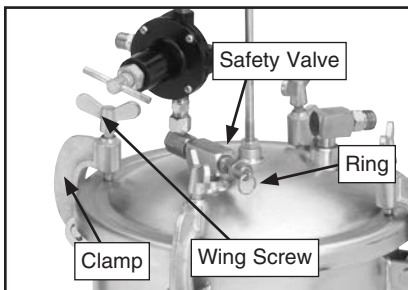

**Figure 5.** Safety valve ring.

3. Turn the tank regulator T-handle counterclockwise until you no longer feel spring tension.
  4. Loosen the wing screws on the tank lid (**Figure 4**), tip the clamps back, and tip the tank lid to one side.
  5. Loosen the spray gun atomizing cap retaining ring about three turns, then turn **ON** the gun air supply.
  6. Cover the cap with a cloth and pull the trigger to force the material back through the hose and into the tank.
  7. Empty and clean the tank of all paint, and fill it with solvent.
  8. Replace the lid, tighten the clamps, and spray the gun until it sprays clean solvent.
- Note:** Check with local laws regarding this practice and proper solvent disposal. If you are spraying on a regular basis, spraying solvents into the air may be illegal. A cabinet style spray gun cleaner may be required.
9. Use solvent to thoroughly rinse all parts that came in contact with the material, then dry with compressed air or let air dry.
  10. Make sure all the fittings on the tank and regulator, valve, and material hose are free of hardened material that could prevent free movement of air.

# Tank Troubleshooting

Symptom	Possible Cause	Solution
Air escaping from regulator port.	1. Broken or damaged diaphragm in tank regulator.	1. Replace tank regulator.
Pressure dropping slowly on regulator.	1. Dirty or worn valve seat in regulator. 2. Loose air fittings leaking air.	1. Replace tank regulator. 2. Tighten loose air fittings or remove and re-install with new pipe thread tape.
Fluid or air leak at lid gasket.	1. Defective lid gasket. 2. Wing screw loose. 3. Dirt or foreign object between gasket and rim.	1. Replace lid gasket. 2. Tighten wing screws evenly. 3. Clean rim and gasket.
Paint tends to settle rapidly in tank.	1. Paint not mixed or thinned sufficiently.	1. Mix or thin paint according to manufacturer's instructions.
Gauge not registering air pressure.	1. Air pressure turned <b>OFF</b> . 2. Defective pressure gauge.	1. Turn air pressure <b>ON</b> . 2. Replace pressure gauge.
Safety valve popping out.	1. Tank pressure too high. 2. Defective safety valve.	1. Reduce tank pressure to 25-30 PSI (See <b>Page 7</b> ). 2. Replace safety valve.

# H6330 PAINT TANK

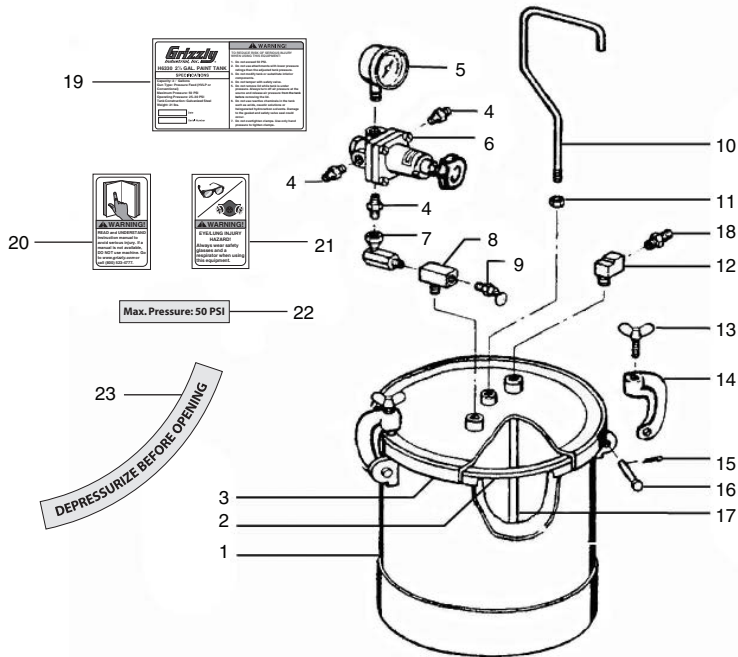

REF PART #	DESCRIPTION
1	PH8225018 TANK SHELL ASSEMBLY
2	PH8225017 LID GASKET
3	PH8225016 LID ASSEMBLY
4	PH8225015 ADAPTER
5	PH8225014 GAUGE
6	PH8225013 REGULATOR
7	PH8225012 SWIVEL ADAPTOR
8	PH8225011 T-BRANCH
9	PH8225010 SAFETY VALVE
10	PH8225009 HANDLE M8-1.25
11	PN03M HEX NUT M8-1.25
12	PH8225007 FLUID OUTLET

REF PART #	DESCRIPTION
13	PH8225006 WING SCREW M10-1.5 X 40
14	PH8225005 LID CLAMP
15	PH8225004 COTTER PIN 2 X 30
16	PH8225003 CLEVIS PIN 3/8 X 1-1/4
17	PH8225002 FLUID TUBE
18	PH8225001 FLUID OUTLET ADAPTER
19	PH6330019 MACHINE ID LABEL FOR H6330
20	PLABEL-12A READ MANUAL LABEL-VERT.
21	PLABEL-37 RESPIRATOR/GLASSES LABEL
22	PH8225026 MAXIMUM PRESSURE LABEL
23	PH8225027 DEPRESSURIZE LABEL

# WARRANTY

---

---

Grizzly Industrial, Inc. warrants every product it sells for a period of **1 year** to the original purchaser from the date of purchase. This warranty does not apply to defects due directly or indirectly to misuse, abuse, negligence, accidents, repairs or alterations or lack of maintenance. This is Grizzly's sole written warranty and any and all warranties that may be implied by law, including any merchantability or fitness, for any particular purpose, are hereby limited to the duration of this written warranty. We do not warrant or represent that the merchandise complies with the provisions of any law or acts unless the manufacturer so warrants. In no event shall Grizzly's liability under this warranty exceed the purchase price paid for the product and any legal actions brought against Grizzly shall be tried in the State of Washington, County of Whatcom.

We shall in no event be liable for death, injuries to persons or property or for incidental, contingent, special, or consequential damages arising from the use of our products.

To take advantage of this warranty, contact us by mail or phone and give us all the details. We will then issue you a "Return Authorization Number," which must be clearly posted on the outside as well as the inside of the carton. We will not accept any item back without this number. Proof of purchase must accompany the merchandise.

The manufacturers reserve the right to change specifications at any time because they constantly strive to achieve better quality equipment. We make every effort to ensure that our products meet high quality and durability standards and we hope you never need to use this warranty.

Please feel free to write or call us if you have any questions about the machine or the manual.

**Grizzly Industrial, Inc.**  
**1203 Lycoming Mall Circle**  
**Muncy, PA 17756**  
**Phone: (570) 546-9663**  
**Fax: (800) 438-5901**

**E-Mail:**  
**techsupport@grizzly.com**

**Web Site: <http://www.grizzly.com>**

Thank you again for your business and continued support. We hope to serve you again soon!



# WARRANTY CARD

Name \_\_\_\_\_

Street \_\_\_\_\_

City \_\_\_\_\_ State \_\_\_\_\_ Zip \_\_\_\_\_

Phone # \_\_\_\_\_ Email \_\_\_\_\_ Invoice # \_\_\_\_\_

Model # \_\_\_\_\_ Order # \_\_\_\_\_ Serial # \_\_\_\_\_

*The following information is given on a voluntary basis. It will be used for marketing purposes to help us develop better products and services. All information is strictly confidential.*

1. How did you learn about us?

Advertisement     Friend     Catalog  
 Card Deck     Website    Other: \_\_\_\_\_

2. Which of the following magazines do you subscribe to?

<input type="checkbox"/> Cabinet Maker	<input type="checkbox"/> Popular Mechanics	<input type="checkbox"/> Today's Homeowner
<input type="checkbox"/> Family Handyman	<input type="checkbox"/> Popular Science	<input type="checkbox"/> Wood
<input type="checkbox"/> Hand Loader	<input type="checkbox"/> Popular Woodworking	<input type="checkbox"/> Wooden Boat
<input type="checkbox"/> Handy	<input type="checkbox"/> Practical Homeowner	<input type="checkbox"/> Woodshop News
<input type="checkbox"/> Home Shop Machinist	<input type="checkbox"/> Precision Shooter	<input type="checkbox"/> Woodsmith
<input type="checkbox"/> Journal of Light Cont.	<input type="checkbox"/> Projects in Metal	<input type="checkbox"/> Woodwork
<input type="checkbox"/> Live Steam	<input type="checkbox"/> RC Modeler	<input type="checkbox"/> Woodworker West
<input type="checkbox"/> Model Airplane News	<input type="checkbox"/> Rifle	<input type="checkbox"/> Woodworker's Journal
<input type="checkbox"/> Modeltec	<input type="checkbox"/> Shop Notes	<input type="checkbox"/> Other: _____
<input type="checkbox"/> Old House Journal	<input type="checkbox"/> Shotgun News	

3. What is your annual household income?

\$20,000-\$29,000     \$30,000-\$39,000     \$40,000-\$49,000  
 \$50,000-\$59,000     \$60,000-\$69,000     \$70,000+

4. What is your age group?

20-29     30-39     40-49  
 50-59     60-69     70+

5. How long have you been a woodworker/metalworker?

0-2 Years     2-8 Years     8-20 Years     20+ Years

6. How many of your machines or tools are Grizzly?

0-2     3-5     6-9     10+

7. Do you think your machine represents a good value?  Yes     No

8. Would you recommend Grizzly Industrial to a friend?  Yes     No

9. Would you allow us to use your name as a reference for our customers in your area?

Note: *We never use names more than 3 times.*     Yes     No

10. Comments: \_\_\_\_\_

\_\_\_\_\_

\_\_\_\_\_

\_\_\_\_\_

Send a Grizzly Catalog to a friend:

Name _____
Street _____
City _____ State _____ Zip _____

FOLD ALONG DOTTED LINE

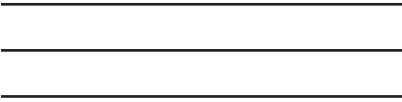

Place  
Stamp  
Here



GRIZZLY INDUSTRIAL, INC.  
P.O. BOX 2069  
BELLINGHAM, WA 98227-2069



TAPE ALONG EDGES--PLEASE DO NOT STAPLE