

READ THIS FIRST

Model M1036

IMPORTANT UPDATE

Applies to Models Mfd. Since 5/19
and Owner's Manual Revised 7/13



Phone #: (360) 734-3482 • Tech Support: techsupport@woodstockint.com • Web: www.woodstockint.com

We made the following changes to this machine since the manual was printed:

- Changed size of motor pulley and drive belt.

Aside from the information contained in this update, all other content in the owner's manual is applicable and **MUST** be read and understood for your own safety.

IMPORTANT: Keep this update with the owner's manual for future reference. If you have any further questions, contact our Technical Support.

Revised Parts

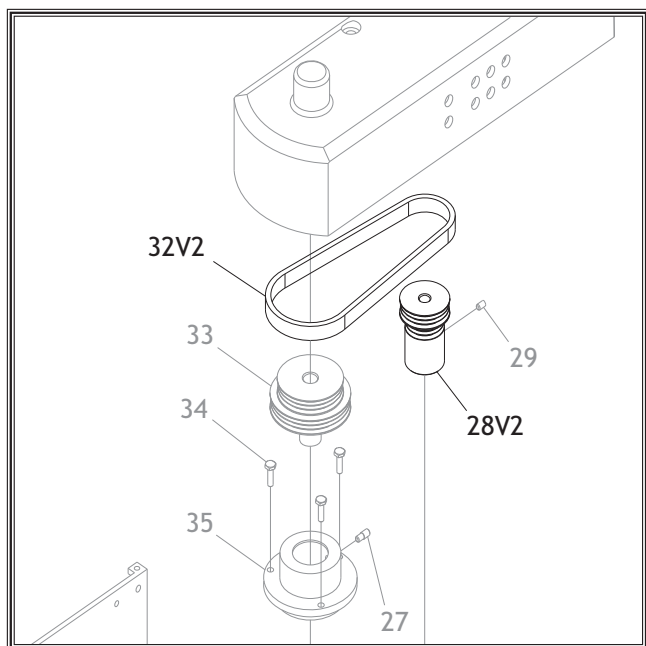

REF	PART #	DESCRIPTION
28V2	XM1036028V2	MOTOR PULLEY 16MM V2.05.19
32V2	XM1036032V2	POLY V-BELT 3V X 28.5L V2.05.19

COPYRIGHT © SEPTEMBER, 2019 BY WOODSTOCK INTERNATIONAL, INC.

WARNING: NO PORTION OF THIS MANUAL MAY BE REPRODUCED IN ANY SHAPE OR FORM WITHOUT

#20625AI

THE WRITTEN APPROVAL OF WOODSTOCK INTERNATIONAL, INC.

Printed in China

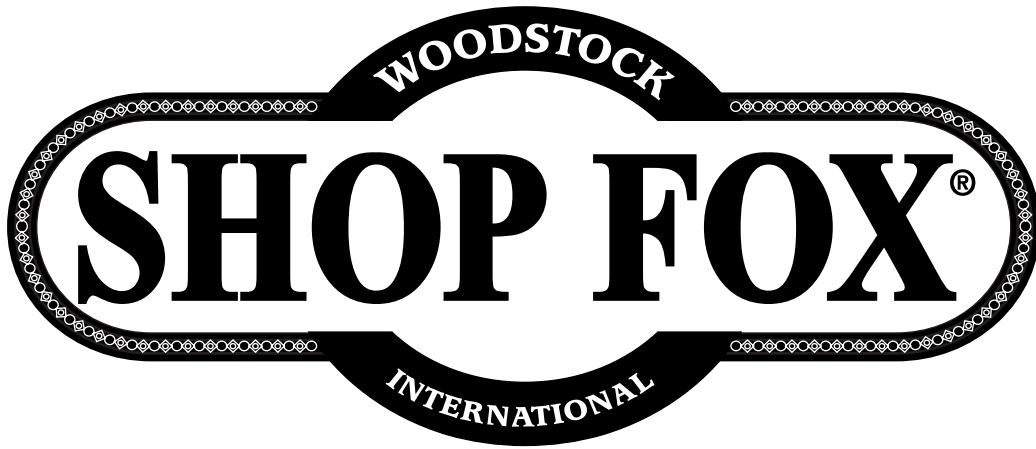

MODEL M1036 MICRO MILL



OWNER'S MANUAL

(FOR MODELS MANUFACTURED SINCE 11/05)

Phone: (360) 734-3482 • Online Technical Support: tech-support@shopfox.biz

COPYRIGHT © NOVEMBER, 2005 BY WOODSTOCK INTERNATIONAL, INC. REVISED JULY, 2013 (DM)

WARNING: NO PORTION OF THIS MANUAL MAY BE REPRODUCED IN ANY SHAPE OR FORM WITHOUT

THE WRITTEN APPROVAL OF WOODSTOCK INTERNATIONAL, INC.

#7735EW Printed in CHINA

 **WARNING!**

This manual provides critical safety instructions on the proper setup, operation, maintenance, and service of this machine/tool. Save this document, refer to it often, and use it to instruct other operators.

Failure to read, understand and follow the instructions in this manual may result in fire or serious personal injury—including amputation, electrocution, or death.

The owner of this machine/tool is solely responsible for its safe use. This responsibility includes but is not limited to proper installation in a safe environment, personnel training and usage authorization, proper inspection and maintenance, manual availability and comprehension, application of safety devices, cutting/sanding/grinding tool integrity, and the usage of personal protective equipment.

The manufacturer will not be held liable for injury or property damage from negligence, improper training, machine modifications or misuse.

 **WARNING!**

Some dust created by power sanding, sawing, grinding, drilling, and other construction activities contains chemicals known to the State of California to cause cancer, birth defects or other reproductive harm. Some examples of these chemicals are:

- Lead from lead-based paints.
- Crystalline silica from bricks, cement and other masonry products.
- Arsenic and chromium from chemically-treated lumber.

Your risk from these exposures varies, depending on how often you do this type of work. To reduce your exposure to these chemicals: Work in a well ventilated area, and work with approved safety equipment, such as those dust masks that are specially designed to filter out microscopic particles.

TABLE OF CONTENTS

INTRODUCTION	2	MAINTENANCE	26
Woodstock Technical Support	2	General	26
Controls and Features	5	Cleaning	26
SAFETY	6	Table & Base	26
Standard Machinery Safety Instructions	6	Lubrication	27
Additional Safety for Milling Machines	8	SERVICE	28
ELECTRICAL	9	General	28
Circuit Requirements	9	Gibs.....	28
Grounding Requirements.....	10	Replacing Motor Brushes	29
Extension Cords	10	Fuse Replacement.....	29
SETUP	11	Electrical Components	30
Unpacking	11	Wiring Diagram	30
Items Needed	11	Troubleshooting.....	31
Inventory	12	PARTS	32
Cleanup	13	Parts List.....	33
Site Considerations	13	WARRANTY	37
Mounting to Workbench	14		
Mounting Headstock to Column.....	14		
Compound Slide Table	15		
Vise	15		
Test Run and Spindle Break-in	16		
OPERATIONS	17		
General	17		
Table Travel	18		
Graduated Dials	18		
Backlash	19		
Headstock Height	19		
Downfeed Controls.....	20		
Digital Height Gauge.....	21		
Depth Stop	22		
Changing RPM.....	22		
Drill Chuck.....	23		
Drill Chuck Removal	23		
Collets	24		
ACCESSORIES	25		



INTRODUCTION

Woodstock Technical Support

Woodstock International, Inc. is committed to customer satisfaction. Our intent with this manual is to include the basic information for safety, setup, operation, maintenance, and service of this product.

In the event that questions arise about your machine, please contact Woodstock International Technical Support at (360) 734-3482 or send e-mail to: tech-support@shopfox.biz. Our knowledgeable staff will help you troubleshoot problems or process warranty claims.

If you need the latest edition of this manual, you can download it from <http://www.shopfox.biz>.
If you have comments about this manual, please contact us at:

Woodstock International, Inc.
Attn: Technical Documentation Manager
P.O. Box 2309
Bellingham, WA 98227
Email: manuals@woodstockint.com



MACHINE SPECIFICATIONS



© Woodstock International, Inc. • Phone: (800) 840-8420 • Web: www.shopfox.biz

MODEL M1036 MICRO MILLING MACHINE

Product Dimensions

Weight..... 31 lbs.
 Width (side-to-side) x Depth (front-to-back) x Height..... 11 x 14 x 19 in.
 Footprint (Length x Width)..... 11 x 6-1/2 in.

Shipping Dimensions

Type..... Cardboard Box
 Content..... Machine
 Weight..... 30 lbs.
 Length x Width x Height..... 25 x 16 x 12 in.

Electrical

Power Requirement..... 110V, Single-Phase, 60 Hz
 Prewired Voltage..... 110V
 Full-Load Current Rating..... 2A
 Minimum Circuit Size..... 15A
 Connection Type..... Cord & Plug
 Power Cord Included..... Yes
 Plug Included..... Yes
 Included Plug Type..... 5-15
 Switch Type..... Rocker Switch & Variable-Speed Dial

Motors

Main

Type..... ODP Permanent-Split Capacitor
 Horsepower..... 0.2 HP
 Phase..... Single-Phase
 Amps..... 2A
 Bearings..... Sealed & Permanently Lubricated

Main Specifications

Operation Info

Spindle Travel..... 1-1/2 in.
 Max Distance Spindle to Column..... 6-1/2 in.
 Longitudinal Table Travel (X-Axis)..... 5-1/2 in.
 Cross Table Travel (Y-Axis)..... 5-1/2 in.
 Vertical Head Travel (Z-Axis)..... 7-3/4 in.
 Turret or Column Swivel (Left /Right)..... 360 deg.
 Drilling Capacity for Steel..... 1/4 in.

Spindle Info

Spindle Taper..... JT#1
 Range of Vertical Spindle Speeds..... 0 - 5000 RPM



Construction

Spindle Housing/Quill..... Chrome-Plated & Precision-Ground Steel
 Table..... Ground Cast Iron
 Base..... Cast Iron
 Paint..... Enamel

Other

Country Of Origin China
 Warranty 2 Years
 Approximate Assembly & Setup Time 30 Minutes
 ISO 9001 Factory Yes
 CSA Certified No

Features

Digital depth readout
 Compound slide table
 Variable speed, 0-5000 RPM

Controls and Features

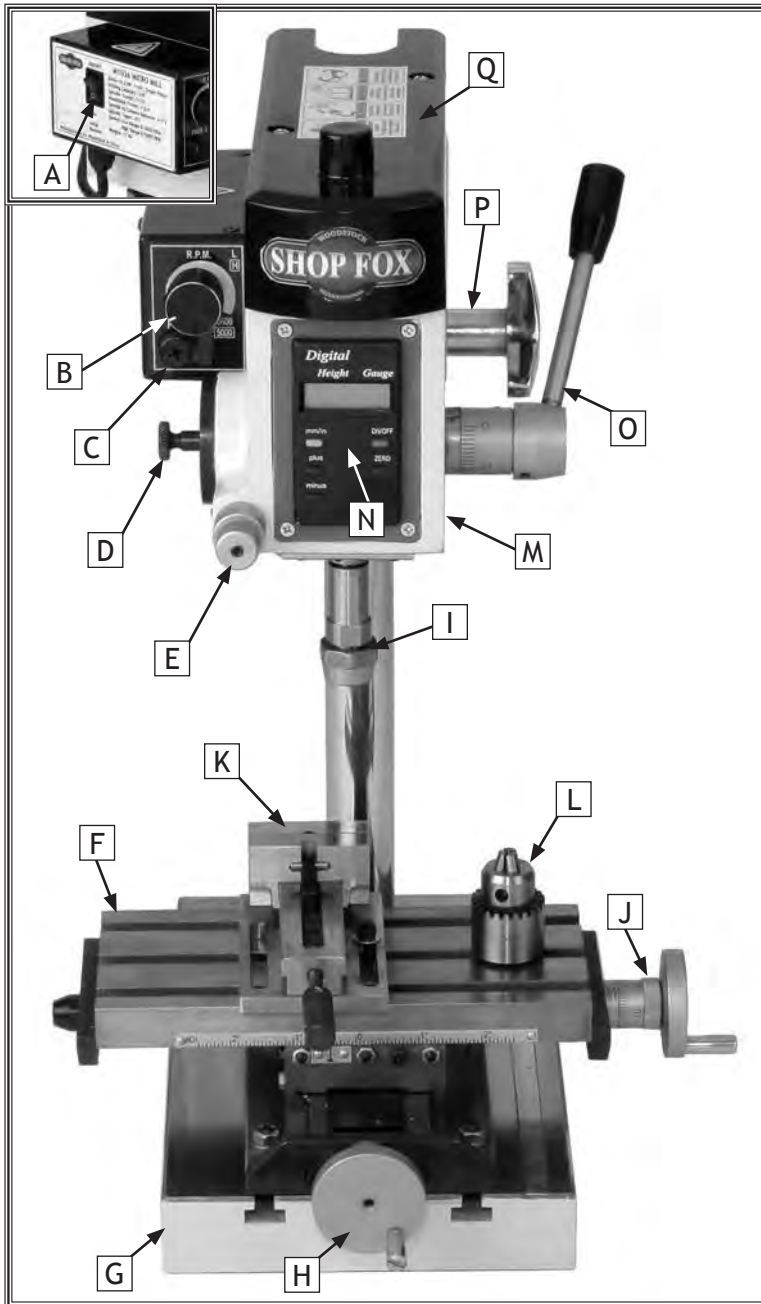

- A. ON/OFF Switch
- B. RPM Control Knob
- C. Fuse Box
- D. Clutch Knob
- E. Micro Downfeed Knob
- F. Compound Slide Table
- G. Base
- H. Crossfeed Handwheel
- I. Collet Chuck (Optional Accessory)
- J. Longitudinal Handwheel
- K. Vise (Optional Accessory)
- L. Drill Chuck
- M. Headstock
- N. Digital Height Gauge
- O. Downfeed Lever
- P. Column Lock Knob
- Q. Pulley Cover

Figure 1. M1036 Controls and features.

SAFETY

For Your Own Safety, Read Manual Before Operating Machine

The purpose of safety symbols is to attract your attention to possible hazardous conditions. This manual uses a series of symbols and signal words intended to convey the level of importance of the safety messages. The progression of symbols is described below. Remember that safety messages by themselves do not eliminate danger and are not a substitute for proper accident prevention measures—this responsibility is ultimately up to the operator!



Indicates an imminently hazardous situation which, if not avoided, **WILL** result in death or serious injury.



Indicates a potentially hazardous situation which, if not avoided, **COULD** result in death or serious injury.



Indicates a potentially hazardous situation which, if not avoided, **MAY** result in minor or moderate injury.

NOTICE

This symbol is used to alert the user to useful information about proper operation of the equipment or a situation that may cause damage to the machinery.

Standard Machinery Safety Instructions

OWNER'S MANUAL. Read and understand this owner's manual **BEFORE** using machine.

TRAINED OPERATORS ONLY. Untrained operators have a higher risk of being hurt or killed. Only allow trained/supervised people to use this machine. When machine is not being used, disconnect power, remove switch keys, or lock-out machine to prevent unauthorized use—especially around children. Make workshop kid proof!

DANGEROUS ENVIRONMENTS. Do not use machinery in areas that are wet, cluttered, or have poor lighting. Operating machinery in these areas greatly increases the risk of accidents and injury.

MENTAL ALERTNESS REQUIRED. Full mental alertness is required for safe operation of machinery. Never operate under the influence of drugs or alcohol, when tired, or when distracted.

ELECTRICAL EQUIPMENT INJURY RISKS. You can be shocked, burned, or killed by touching live electrical components or improperly grounded machinery. To reduce this risk, only allow an electrician or qualified service personnel to do electrical installation or repair work, and always disconnect power before accessing or exposing electrical equipment.

DISCONNECT POWER FIRST. Always disconnect machine from power supply **BEFORE** making adjustments, changing tooling, or servicing machine. This eliminates the risk of injury from unintended startup or contact with live electrical components.

EYE PROTECTION. Always wear ANSI-approved safety glasses or a face shield when operating or observing machinery to reduce the risk of eye injury or blindness from flying particles. Everyday eyeglasses are not approved safety glasses.

WEARING PROPER APPAREL. Do not wear clothing, apparel, or jewelry that can become entangled in moving parts. Always tie back or cover long hair. Wear non-slip footwear to avoid accidental slips, which could cause loss of workpiece control.

HAZARDOUS DUST. Dust created while using machinery may cause cancer, birth defects, or long-term respiratory damage. Be aware of dust hazards associated with each workpiece material, and always wear a NIOSH-approved respirator to reduce your risk.

HEARING PROTECTION. Always wear hearing protection when operating or observing loud machinery. Extended exposure to this noise without hearing protection can cause permanent hearing loss.

REMOVE ADJUSTING TOOLS. Tools left on machinery can become dangerous projectiles upon startup. Never leave chuck keys, wrenches, or any other tools on machine. Always verify removal before starting!

INTENDED USAGE. Only use machine for its intended purpose and never make modifications not approved by Woodstock. Modifying machine or using it differently than intended may result in malfunction or mechanical failure that can lead to serious personal injury or death!

AWKWARD POSITIONS. Keep proper footing and balance at all times when operating machine. Do not overreach! Avoid awkward hand positions that make workpiece control difficult or increase the risk of accidental injury.

CHILDREN & BYSTANDERS. Keep children and bystanders at a safe distance from the work area. Stop using machine if they become a distraction.

GUARDS & COVERS. Guards and covers reduce accidental contact with moving parts or flying debris—make sure they are properly installed, undamaged, and working correctly.

FORCING MACHINERY. Do not force machine. It will do the job safer and better at the rate for which it was designed.

NEVER STAND ON MACHINE. Serious injury may occur if machine is tipped or if the cutting tool is unintentionally contacted.

STABLE MACHINE. Unexpected movement during operation greatly increases risk of injury or loss of control. Before starting, verify machine is stable and mobile base (if used) is locked.

USE RECOMMENDED ACCESSORIES. Consult this owner's manual or the manufacturer for recommended accessories. Using improper accessories will increase risk of serious injury.

UNATTENDED OPERATION. To reduce the risk of accidental injury, turn machine **OFF** and ensure all moving parts completely stop before walking away. Never leave machine running while unattended.

MAINTAIN WITH CARE. Follow all maintenance instructions and lubrication schedules to keep machine in good working condition. A machine that is improperly maintained could malfunction, leading to serious personal injury or death.

CHECK DAMAGED PARTS. Regularly inspect machine for any condition that may affect safe operation. Immediately repair or replace damaged or mis-adjusted parts before operating machine.

MAINTAIN POWER CORDS. When disconnecting cord-connected machines from power, grab and pull the plug—NOT the cord. Pulling the cord may damage the wires inside, resulting in a short. Do not handle cord/plug with wet hands. Avoid cord damage by keeping it away from heated surfaces, high traffic areas, harsh chemicals, and wet/damp locations.

EXPERIENCING DIFFICULTIES. If at any time you experience difficulties performing the intended operation, stop using the machine! Contact Technical Support at (360) 734-3482.

Additional Safety for Milling Machines

SAFETY

UNDERSTANDING CONTROLS. The mill is a complex machine that presents severe cutting or amputation hazards if used incorrectly. Make sure you understand the use and operation of all controls before you begin milling.

SPINDLE SPEED. To avoid tool or workpiece breakage that could send flying debris at the operator and bystanders, use the correct spindle speed for the operation. Allow the spindle to gain full speed before beginning the cut.

CHIP CLEANUP. Chips from the operation are sharp and hot. Touching them can cause burns or cuts. Using compressed air to clear chips could cause them to fly into your eyes, and may drive them deep into the working parts of the machine. Use a brush or vacuum to clear away chips and debris from machine or workpiece and NEVER clear chips while spindle is turning.

CUTTING TOOL USAGE. Cutting tools have very sharp leading edges—handle them with care! Using cutting tools that are in good condition helps to ensure quality milling results and reduces risk of personal injury from broken tool debris. Inspect cutting tools for sharpness, chips, or cracks before each use, and ALWAYS make sure cutting tools are firmly held in place before starting the machine.

STOPPING SPINDLE. To reduce the risk of hand injuries or entanglement hazards, DO NOT attempt to stop the spindle with your hand or a tool. Allow the spindle to stop on its own or use the spindle brake.

MACHINE CARE & MAINTENANCE. Operating the mill with excessively worn or damaged machine parts increases risk of machine or workpiece breakage which could eject hazardous debris at the operator. Operating a mill in poor condition will also reduce the quality of the results. To reduce this risk, maintain the mill in proper working condition by ALWAYS promptly performing routine inspections and maintenance.

SAFETY ACCESSORIES. Flying chips or debris from the cutting operation can cause eye injury or blindness. Always use safety glasses or a face shield when milling.

WORK HOLDING. Before starting the machine, be certain the workpiece has been properly clamped to the table. NEVER hold the workpiece by hand during operation. Milling a workpiece that is not properly secured to the table or in a vise could cause the workpiece to be ejected at the operator with deadly force!



! WARNING
 READ and understand this entire manual before using this machine. Serious personal injury may occur if safety and operational information is not understood and followed. DO NOT risk your safety by not reading!

! CAUTION
 USE this and other machinery with caution and respect. Always consider safety first, as it applies to your individual working conditions. No list of safety guidelines can be complete—every shop environment is different. Failure to follow guidelines could result in serious personal injury, damage to equipment or poor work results.

ELECTRICAL

Circuit Requirements

This machine must be connected to the correct size and type of power supply circuit, or fire or electrical damage may occur. Read through this section to determine if an adequate power supply circuit is available. If a correct circuit is not available, a qualified electrician **MUST** install one before you can connect the machine to power.

A power supply circuit includes all electrical equipment between the breaker box or fuse panel in the building and the machine. The power supply circuit used for this machine must be sized to safely handle the full-load current drawn from the machine for an extended period of time. (If this machine is connected to a circuit protected by fuses, use a time delay fuse marked D.)

Full-Load Current Rating

The full-load current rating is the amperage a machine draws at 100% of the rated output power. On machines with multiple motors, this is the amperage drawn by the largest motor or sum of all motors and electrical devices that might operate at one time during normal operations.

Full-Load Current Rating at 110V2 Amps

Circuit Requirements for 110V

This machine is prewired to operate on a 110V power supply circuit that has a verified ground and meets the following requirements:

Circuit Type 110V/120V, 60 Hz, Single-Phase
Circuit Size 15 Amps
Plug/Receptacle NEMA 5-15

⚠ WARNING

The machine must be properly set up before it is safe to operate. **DO NOT** connect this machine to the power source until instructed to do so later in this manual.

⚠ WARNING



Incorrectly wiring or grounding this machine can cause electrocution, fire, or machine damage. To reduce this risk, only an electrician or qualified service personnel should do any required electrical work on this machine.

NOTICE

The circuit requirements listed in this manual apply to a dedicated circuit—where only one machine will be running at a time. If this machine will be connected to a shared circuit where multiple machines will be running at the same time, consult with an electrician to ensure that the circuit is properly sized for safe operation.

ELECTRICAL

Grounding Requirements

This machine **MUST** be grounded. In the event of certain types of malfunctions or breakdowns, grounding provides a path of least resistance for electric current to travel—in order to reduce the risk of electric shock.

Improper connection of the equipment-grounding wire will increase the risk of electric shock. The wire with green insulation (with/without yellow stripes) is the equipment-grounding wire. If repair or replacement of the power cord or plug is necessary, do not connect the equipment-grounding wire to a live (current carrying) terminal.

Check with a qualified electrician or service personnel if you do not understand these grounding requirements, or if you are in doubt about whether the tool is properly grounded. If you ever notice that a cord or plug is damaged or worn, disconnect it from power, and immediately replace it with a new one.

For 110V Connection

This machine is equipped with a power cord that has an equipment-grounding wire and NEMA 5-15 grounding plug. The plug must only be inserted into a matching receptacle (see **Figure**) that is properly installed and grounded in accordance with local codes and ordinances.

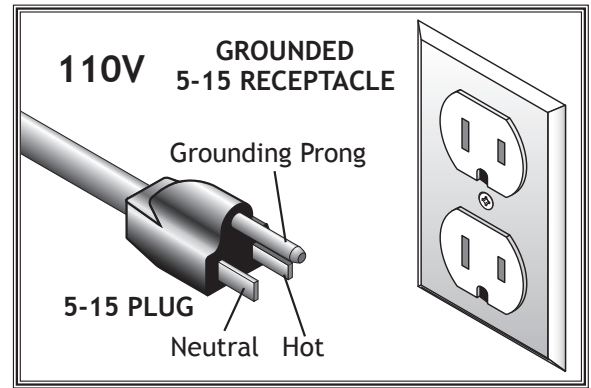
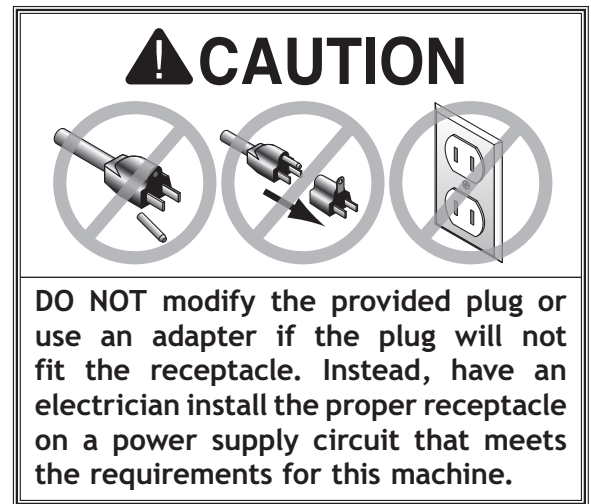

Figure 2. NEMA 5-15 plug & receptacle.



Extension Cords

We do not recommend using an extension cord with this machine. Extension cords cause voltage drop, which may damage electrical components and shorten motor life. Voltage drop increases with longer extension cords and the gauge smaller gauge sizes (higher gauge numbers indicate smaller sizes).

Any extension cord used with this machine must contain a ground wire, match the required plug and receptacle, and meet the following requirements:

- Minimum Gauge Size at 110V 16 AWG
- Maximum Length (Shorter is Better) 50 ft.

ELECTRICAL

SETUP

Unpacking

This machine has been carefully packaged for safe transportation. If you notice the machine has been damaged during shipping, please contact your authorized Shop Fox dealer immediately.

Items Needed

The following items are needed, but not included, to setup your machine:

Description	Qty
• Safety Glasses (for each person).....	1
• Solvent	1
• Shop Rags	1
• Wrench or Socket 10mm	1
• Ruler	1
Bench Mounting Hardware (Optional)	Qty
• Precision Level	1
• Phillips Head Screw 6mm x Length Varies	2
• Hex Nut 6mm	2
• Flat Washer 6mm	2
• Metal Shim Stock	1
• Drill and 6mm Bit.....	1

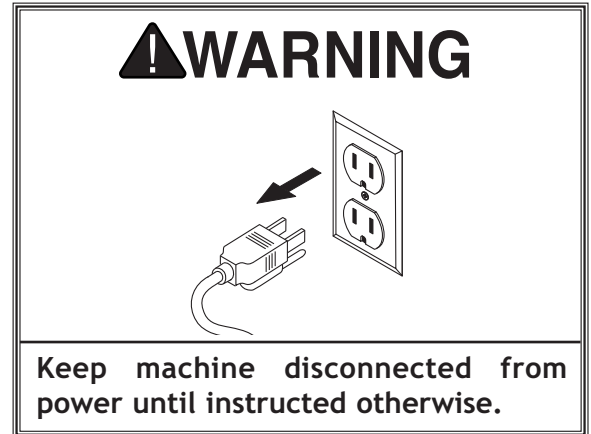

SET UP

Inventory

The following is a description of the main components shipped with the Model M1036. Lay the components out to inventory them.

Note: *If you can't find an item on this list, check the mounting location on the machine or examine the packaging materials carefully. Occasionally we pre-install certain components for safer shipping.*

Box 1 Contents (Figure 3)	Qty
A. Headstock.....	1
B. Collar	1
C. Spacer	1
D. Base with Column	1
E. Downfeed Lever Handle	1
F. Column Lock Knob.....	1
G. Fence	1

Box 1 Tools and Hardware (Not Shown)	Qty
• Phillips Head Screwdriver	1
• Hex Wrenches 2, 2.5, 3, 4mm.....	1 Each
• Open End Wrench 5.5/7mm	1
• Chuck Removal Wedge.....	1
• Round Belt.....	1
• Cap Screw M5-.8 x 12.....	1
• Square Nut M5-.8.....	1

Box 2 Contents (Figure 4)	Qty
H. Compound Slide Table	1
I. Handwheel Handles	2
J. Hardware for Mounting Table-to-Base (not shown)	
• Cap Screws M6-1 x 25.....	4
• T-Nuts M6-1	4

Additional Hardware for Mounting an Optional Vise	Qty
• Cap Screws M6-1 x 30.....	2
• T-Nuts M6-1.....	2

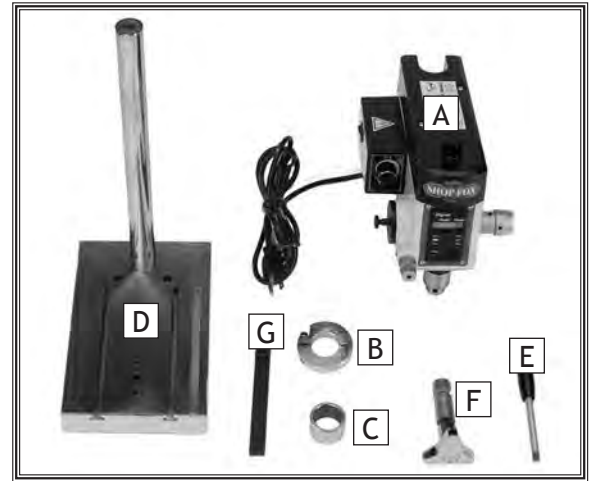

Figure 3. Box 1 contents.

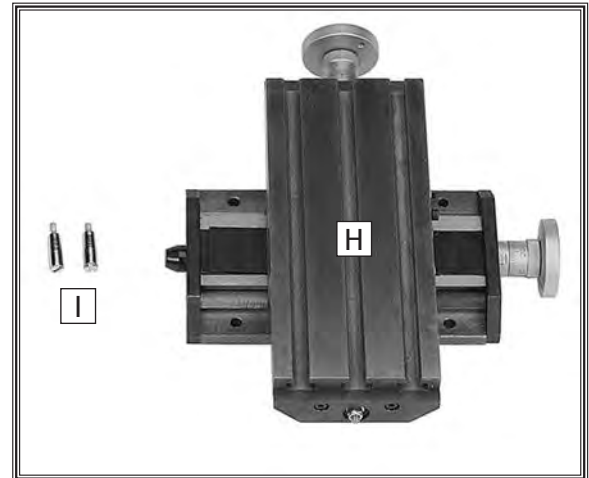

Figure 4. Box 2 contents.

NOTICE

When ordering replacement parts, refer to the parts list and diagram in the back of the manual.

SET UP

Cleanup

The unpainted surfaces of your machine are coated with a heavy-duty rust preventative that prevents corrosion during shipment and storage. This rust preventative works extremely well, but it will take a little time to clean.

Be patient and do a thorough job cleaning your machine. The time you spend doing this now will give you a better appreciation for the proper care of your machine's unpainted surfaces.

There are many ways to remove this rust preventative, but the following steps work well in a wide variety of situations. Always follow the manufacturer's instructions with any cleaning product you use and make sure you work in a well-ventilated area to minimize exposure to toxic fumes.

Before cleaning, gather the following:

- Disposable Rags
- Cleaner/degreaser (WD-40 works well)
- Safety glasses & disposable gloves
- Plastic paint scraper (optional)

Basic steps for removing rust preventative:

1. Put on safety glasses.
2. Coat the rust preventative with a liberal amount of cleaner/degreaser, then let it soak for 5-10 minutes.
3. Wipe off the surfaces. If your cleaner/degreaser is effective, the rust preventative will wipe off easily. If you have a plastic paint scraper, scrape off as much as you can first, then wipe off the rest with the rag.
4. Repeat **Steps 2-3** as necessary until clean, then coat all unpainted surfaces with a quality metal protectant to prevent rust.

NOTICE

Avoid chlorine-based solvents, such as acetone or brake parts cleaner, that may damage painted surfaces.

Site Considerations

Workbench Load

Refer to the **Machine Data Sheet** for the weight and footprint specifications of your machine. Some workbenches may require additional reinforcement to support both the machine and materials.

Placement Location

Consider existing and anticipated needs, size of material to be processed through each machine, and space for auxiliary stands, work tables or other machinery when establishing a location for your new machine. See **Figure 5** for the minimum working clearances.

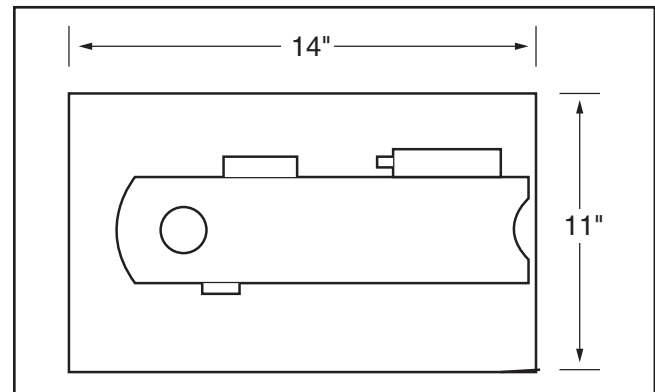

Figure 5. Minimum working clearances.

Mounting to Workbench

Mounting the mill to the workbench provides maximum rigidity and prevents the mill from tipping. Mounting the mill should be done before installing the headstock for the best access to the mounting holes. When choosing a location for the mill, make sure the cross feed and the longitudinal handwheels extend out beyond the edge of the table surface. This will allow unrestricted handwheel operation.

To mount the mill to the workbench, do these steps:

1. Measure the thickness of the workbench and add 1¹/₂" to determine the necessary screw length.
2. Mark your hole locations, using the mounting holes in the base as a guide (see **Figure 6**).
3. Drill ³/₁₆" holes through the workbench.
4. Place a precision level on the mill/drill table and shim the mill/drill until it is level side-to-side and front-to-back.
5. Bolt the mill to the workbench with (2) 6mm cap screws (length determined in **Step 1**), hex nuts and flat washers.

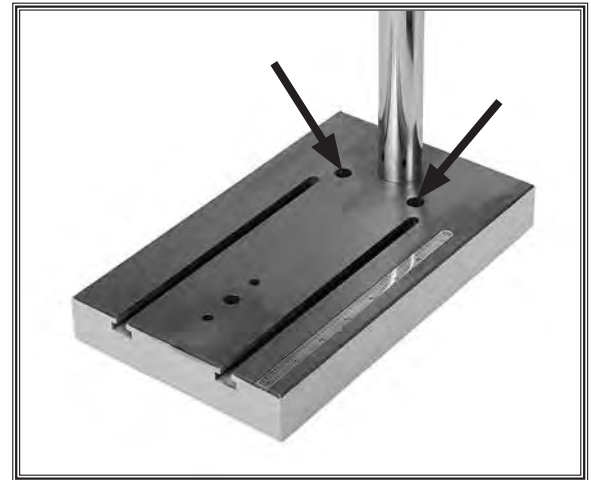

Figure 6. Mounting hole locations.



Figure 7. Collar and spacer installed on the column.

Mounting Headstock to Column

To install the headstock on the column, do these steps:

1. Set the base upright and slide the collar half way down the column.
2. Secure the collar by tightening the cap screw with a 4mm hex wrench, then slide the spacer over the column (see **Figure 7**).
3. Insert the column lock knob assembly into the headstock, as shown in **Figure 8**.
4. Slide the headstock onto the column, line the chuck up with the hole in the base, and lock it in place with the column lock knob.
5. Thread the downfeed lever into the hub and tighten with the included wrench.



Figure 8. Installing the column lock knob.

SET UP

Compound Slide Table

Installation of the compound slide table is not necessary when using the mill as a drill. The compound slide table can be moved in the X and Y axis for use with milling cutters.

To install the compound slide table, do these steps:

1. Thread the handwheel handles into the handwheels.
2. Remove the fence from the base if installed.
3. Slide (4) M6-1 T-nuts into the T-slots, place the compound slide table over the T-slot nuts, and loosely thread the (4) M6-1 x 25 cap screws as shown in **Figure 9**.
4. Measure at the front and back of the compound slide table as shown in **Figure 10** to make sure the compound slide table is parallel to the base.
5. Secure the compound slide table by tightening the cap screws.

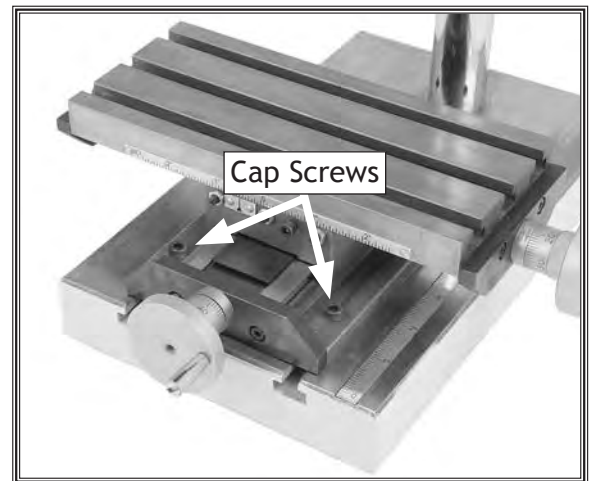

Figure 9. Cap screw and t-nut installation.

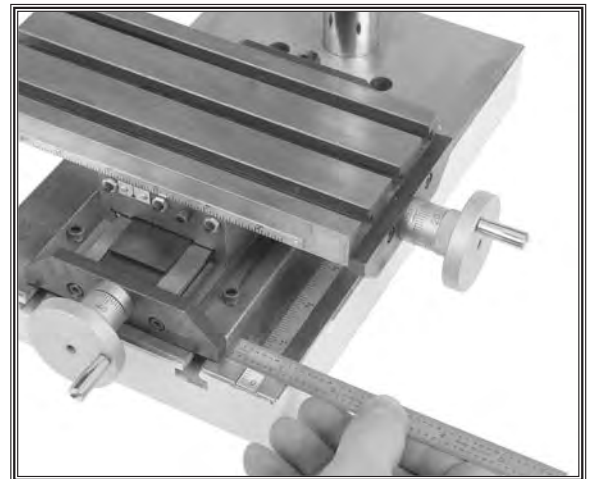

Figure 10. Aligning the compound slide table.

Vise

To install the optional vise, do these steps:

1. Slide the T-nuts into the compound slide table.
2. Place the vise on the compound slide table and loosely secure it by threading (2) M6-1 x 30 cap screws through the vise and into the T-slot nuts, as shown in **Figure 11**.
3. Align the vise parallel to the compound slide table and tighten the cap screws.

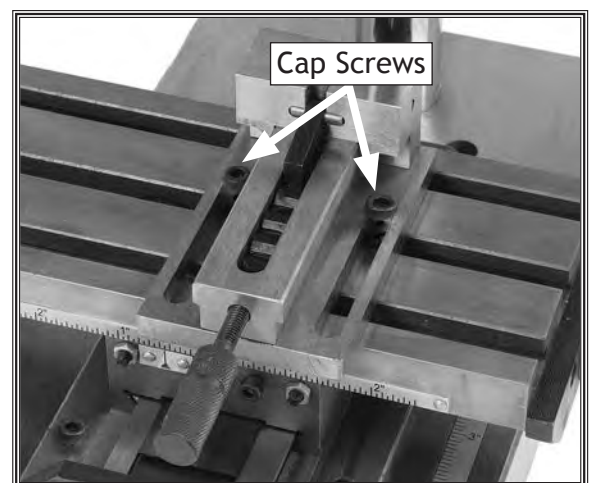

Figure 11. Securing the optional vise.

Test Run and Spindle Break-in

Complete this process once you familiarize yourself with all instructions in this manual and make sure the machine is completely lubricated as described in **Lubrication on Page 27**. It is essential to closely follow the proper break-in procedures to ensure trouble free performance.

To begin the test run and spindle break-in procedure, do these steps:

1. Make sure there are no obstructions around or underneath the spindle.
2. Put on safety glasses, and make sure any bystanders are wearing safety glasses and are out of the way.
3. Set the mill to the slowest RPM, then plug the machine in and turn the "I" position to turn the mill ON. See **Page 22**, for adjusting RPM. The mill should run smoothly, with little or no vibration or rubbing noises.
 - If you hear squealing or grinding noises, turn the machine OFF immediately. Wait for the mill to stop moving, unplug the machine, and correct any problems before further operation.
 - If the source of an unusual noise or vibration is not readily apparent, contact our technical support for help.
4. If the mill runs smoothly, allow it to run for 10 minutes at slow speed.
5. Slowly increase the RPM and allow it to run at a medium RPM for another ten minutes.
6. Slowly increase the RPM and allow it to run at a high RPM for another ten minutes.

NOTICE

Failure to follow the break-in procedures included in this manual may lead to shortened tool life and may void warranty.

OPERATIONS

General

This machine will perform many types of operations that are beyond the scope of this manual. Many of these operations can be dangerous or deadly if performed incorrectly.

The instructions in this section are written with the understanding that the operator has the necessary knowledge and skills to operate this machine. If at any time you are experiencing difficulties performing any operation, stop using the machine!

If you are an inexperienced operator, we strongly recommend that you read books or trade articles, or seek training from an experienced operator of this type of machinery before performing unfamiliar operations. **Above all, safety must come first!**

WARNING



To reduce your risk of serious injury, read this entire manual **BEFORE** using machine.

WARNING

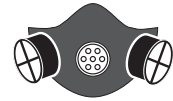

To reduce the risk of eye injury and long-term respiratory damage, always wear safety glasses and a respirator while operating this machine.

Table Travel

The table can be moved in 2 axes. Each axis is independently controlled by a crank handle. Each handle has a graduated dial to accurately position the workpiece in relation to the cutting tool (see **Figure 12**). Each axis has the ability to be locked in position. Locking the axis in place will help keep workpiece vibration to a minimum.

Longitudinal Feed Control

The longitudinal feed is controlled by a crank handle at the end of the table, and can be locked in position by the cap screw located at the front of the table.

Cross Feed Control

The cross feed is controlled by the center crank handle, and can be locked in position by the cap screw located under the left side of the mill table.

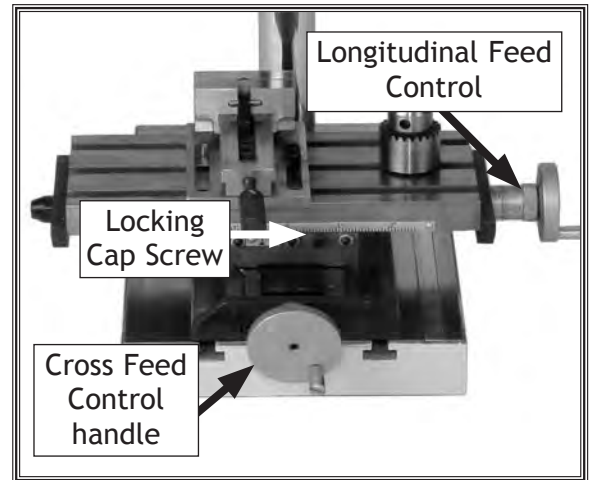

Figure 12. Longitudinal and cross feed table control.

Graduated Dials

Each mark on the handwheel graduated dials (**Figure 13**) represents 0.001" of movement. One full rotation of the handwheel is equal to 0.050". The graduated dials can be "zeroed" by grasping the knurled section and rotating the graduated dial to "0".

Example:

To drill a series of holes with 1/2" centers (0.500"), drill the first hole, zero the graduated dial, move the table 0.500" (10 rotations of the handwheel) in the appropriate direction, then drill the next hole.

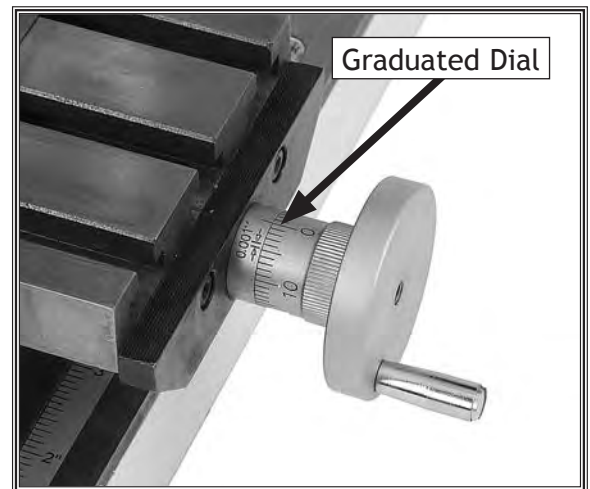

Figure 13. Graduated dial.

Backlash

When changing table direction in either axis, the handwheel will rotate a few degrees before the table begins to move and the graduated dial must be adjusted. This is backlash.

To correct for backlash, do these steps:

1. Turn the handwheel in the opposite direction of your next operation.
2. Turn the handwheel to move the table in the intended direction.
3. When the leadscrew catches and the table begins to move, backlash has been eliminated and the graduated dial can be "zeroed."

Note: You will not need to adjust for backlash as long as the table moves in the same direction.



Figure 14. Headstock height adjustment.

Headstock Height

Adjusting the height of the headstock, instead of extending the quill, maintains the rigidity of the mill and requires less motion when using the downfeed lever.

To adjust the headstock height, do these steps:

1. Loosen the collar (Figure 14) and lower it to the desired height.
2. Loosen the column lock knob and carefully lower the headstock until it rests on the collar spacer.

Note: Raise the headstock by reversing Steps 1 & 2.

Downfeed Controls

Quill Feed Control

The quill feed is controlled by the downfeed lever shown in **Figure 15**. The handle allows the mill to operate as a drill.

To use the downfeed lever, do this step:

1. Pull the quill downfeed lever (**Figure 15**) forward to feed the quill down towards the workpiece. The quill feed handle is spring loaded to assist in returning the handle to the upmost vertical position.

Micro Downfeed Knob

The micro downfeed knob is used to accurately control the quill depth (see **Figure 16**).

To use the micro downfeed handwheel, do these steps:

1. Push the clutch knob (**Figure 16**) in lightly and rotate the micro downfeed knob until the clutch knob engages the gear.
2. Rotate the micro downfeed knob clockwise to feed the quill down and counterclockwise to raise the quill.



Figure 15. Quill downfeed lever.



Figure 16. Micro downfeed controls.

Digital Height Gauge

The digital height gauge (Figure 17) provides accurate height measurements, zeroing at any height, and incremental readout adjustments.

ON/OFF button: Turns the digital height gauge **ON** or **OFF**. This gauge does not automatically turn OFF, so the batteries will die if the gauge is left ON.

ZERO button: Returns the digital readout to 0.000 independent of the height of the quill.

MM/IN button: Changes readout from inches to millimeters.

PLUS and MINUS buttons: Adds or subtracts from the number shown on the digital readout. You must hold the button for several seconds before it begins to function.

When the batteries wear out, open the cover shown in Figure 17 and replace the battery.



Figure 17. Digital height gauge.

Depth Stop

The depth stop allows the operator to make numerous holes that all are the same depth or to hold the mill at a specified depth.

To set the depth stop, do these steps:

1. Use the micro downfeed knob to set the desired depth.
2. To set the quill to repeat the same depth, rotate the graduated dial (**Figure 18**) past the 0 mark until it stops, then tighten the set screw.
3. To lock the quill at the specified depth, rotate the graduated dial past the 30 mark until it stops, then tighten the set screw.

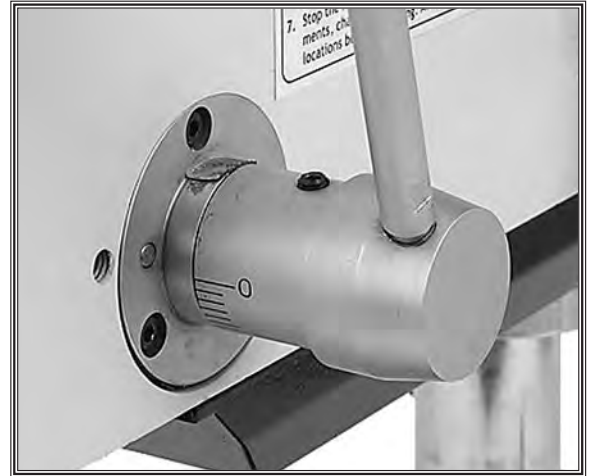

Figure 18. Depth stop.

Changing RPM

The variable speed dial shown in **Figure 19** controls the spindle speed and the pulleys shown in **Figure 20** control the speed range. As a general rule, smaller bits and softer material require higher speeds and less torque, and larger bits and harder materials require slower speeds and greater torque.

To change the RPM, do these steps:

1. Turn the mill **ON** and rotate the RPM dial (**Figure 19**) to reach the desired speed.

To change speed range, do these steps:

1. Remove the pulley cover and loosen the motor mount nuts shown in **Figure 20**.
2. Slide the motor pulley toward the spindle pulley and move the round belt to the other pulley position.

Note: *The upper pulley position is the low range, and the lower pulley position is the high range.*



Figure 19. RPM dial.

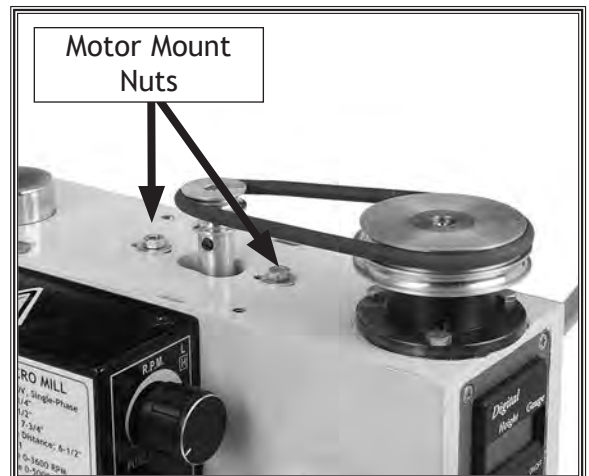

Figure 20. Spindle speed pulleys.

Drill Chuck

The drill chuck will only accept bits with a maximum of 1/4" shank. When installing a bit in the drill chuck, make sure it is tight enough that it will not come loose during operation.

To install a drill bit, do these steps:

1. UNPLUG THE MICRO MILL!
2. Open the drill chuck wide enough to accept the shank of the bit.
3. Insert the bit as far as possible into the chuck WITHOUT allowing the chuck jaws to touch the cutting edges, and hand tighten the chuck.

Note: Make sure small bits are not trapped between the edges of two jaws; if they are, reinstall the bit or it will not be secure enough to use for drilling.

4. Final tighten the drill chuck with the chuck key.

To remove a drill bit, do these steps:

1. UNPLUG THE MICRO MILL!
2. Use the chuck key to open the drill chuck, and catch the bit with a rag to protect your hands.

Drill Chuck Removal

The drill chuck and the collet chuck are attached to the arbor with a JT1 taper. Matched tapers on the arbor and the inside of the chuck use a friction fit to for a semi-permanent assembly.

To remove the drill chuck, do these steps:

1. Protect the table surface with a piece of cardboard, or hold the cutter or tool with a shop towel to prevent it from falling out of the collet.
2. Place the chuck removal wedge (**Figure 22**) between the top of the drill chuck and the spindle (see **Figure 23**), then tap the wedge to separate the chuck from the arbor.



Figure 21. Drill chuck.



Figure 22. Chuck removal wedge.



Figure 23. Drill chuck removal.

Collets

The collet chuck (an optional accessory) for the micro mill offers increased precision and rigidity compared to the drill chuck. Each collet will only fit tooling with a specific shaft diameter. This collet set includes $\frac{1}{4}$ ", $\frac{3}{16}$ ", $\frac{5}{32}$ ", $\frac{5}{64}$ ", $\frac{3}{64}$ " collets.

To install the collet chuck, do these steps:

1. UNPLUG THE MICRO MILL!
2. Remove the drill chuck and clean the arbor and collet chuck tapers with denatured alcohol.
3. Push the collet chuck onto the arbor.
4. Place a piece of wood on the compound slide table and use the downfeed lever to firmly press the collet chuck against the piece of wood (see **Figure 24**) to seat the collet chuck on the arbor.

To install the collet in the collet chuck, do these steps:

1. Place the grooved end of the collet into the collet nut until the off-center lip of the collet nut snaps into the collet groove. See **Figure 25**.

Note: *This lip and groove pulls the collet from the spindle when the collet nut is removed.*

2. Place the collet nut and collet into the collet chuck and finger tighten the collet nut onto the collet chuck.
3. Insert the bit into the collet, place a hex wrench through the hole in the spindle, and tighten the collet with a 22mm wrench (see **Figure 26**).

To remove a bit from the collet chuck, do these steps:

1. Protect the table surface with a piece of cardboard or hold the cutter or tool with a shop towel to prevent it from falling out of the collet.
2. Place a hex wrench through the hole in the spindle and loosen the collet nut with a 22mm wrench until the bit is free.

Note: *Remove the collet chuck in the same manner as removing the drill chuck.*



Figure 24. Installing the collet chuck.



Figure 25. Collet and collet nut lip.

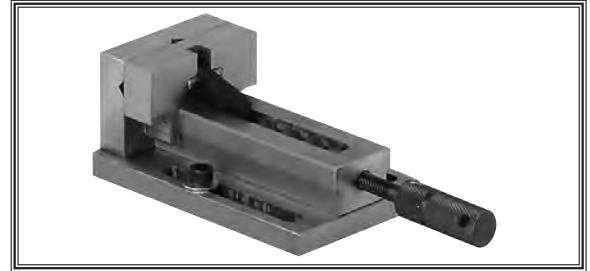

Figure 26. Installing a collet.

ACCESSORIES

The following mill machine accessories may be available through your Woodstock International Inc. Dealer. If you do not have a dealer in your area, these products are also available through online dealers. Please call or e-mail Woodstock International Inc. Customer Service to get a current listing of dealers at: 1-800-840-8420 or at sales@woodstockint.com.

The **SHOP FOX M1038 2⁵/₈" Tall Quick Vise** makes securing your work is quick and easy. A simple pawl engages a rack that is advanced by the vise screw, so very little turning is required to tighten the vise. Includes a sturdy lip along both sides of the base, allowing vise to be mounted to nearly any machine table, using common T-slot clamps.



The **SHOP FOX M1037 5PC. COLLET SET** allows you to quickly switch to the collet that matches the required tooling for the job. This 5-pc. set includes shank with nut and $\frac{3}{64}$ ", $\frac{5}{64}$ ", $\frac{5}{32}$ ", $\frac{3}{16}$ ", and $\frac{1}{4}$ " bits.



The **2-FLUTE (D2699) and 4-FLUTE (D2703) STANDARD SOLID CARBIDE END MILLS** can not be beat for finish and durability. With micro grain structure and precision grinding, these end mills will breeze through the toughest machining jobs. Visit shopfox.biz for additional standard size or long end mills in two- and four-flutes.



The **D4274 Magnetic Base/Dial Indicator Set** features a magnetic base that engages with just the turn of a switch and allows pinpoint adjustment. The dial indicator features 0-1" travel and has a resolution of 0.001". This fine set includes a molded case for protection and convenience. Precision measurements and setups have never been so easy.

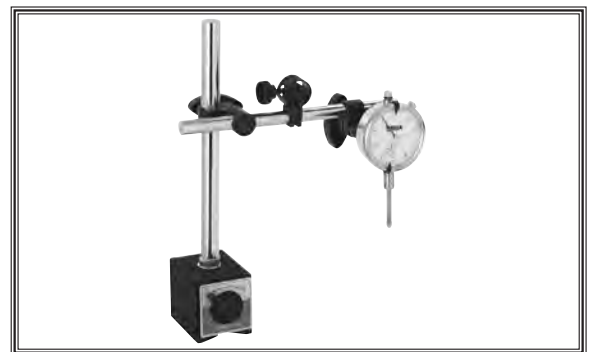

MAINTENANCE

General

Regular periodic maintenance on your machine will ensure its optimum performance. Make a habit of inspecting your machine each time you use it.

Check for the following conditions and repair or replace when necessary:

- Loose mounting bolts.
- Worn switch.
- Worn or damaged cords and plugs.
- Damaged V-belt.
- Any other condition that could hamper the safe operation of this machine.

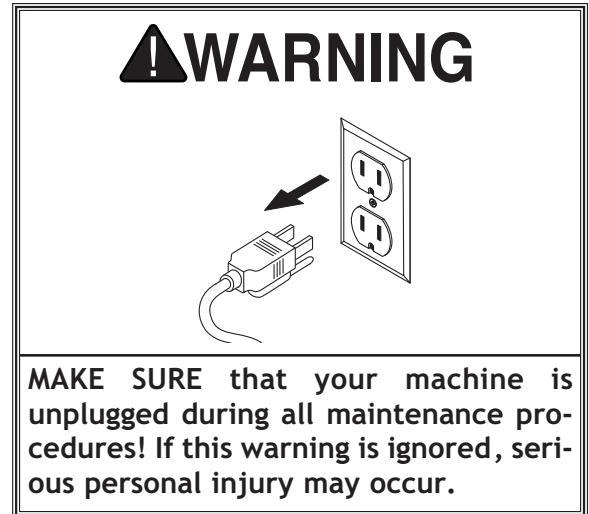

Cleaning

Frequently blow-off sawdust with compressed air. This is especially important for the internal working parts and motor. Dust build-up around the motor is a sure way to decrease its life span.

Occasionally it will become necessary to clean the internal parts with more than compressed air. To do this, remove the table top and clean the internal parts with a citrus cleaner or mineral spirits and a stiff wire brush or steel wool. Make sure the internal workings are dry before using the saw again, so that wood dust will not accumulate. If any essential lubrication is removed during cleaning, relubricate those areas.

Table & Base

Tables can be kept rust-free with regular applications of products like SLIPIT®. For long term storage you may want to consider products like Boeshield T-9™.

Lubrication

Since all bearings are sealed and permanently lubricated, simply leave them alone until they need to be replaced. Do not lubricate them.

This machine does need lubrication in other places. **Lubricate the following areas every six to twelve months according to frequency of use:**

- **Blade angling trunnions.** These should be lubricated with 6 or 7 drops of light machine oil.
- **Blade height trunnion.** This should also be lubricated with 6 or 7 drops of light machine oil.
- **The two worm gears** should be lubricated with either graphite or white lithium grease.

Regular lubrication will ensure your mill performs at its highest potential.

Place two to three drops of ISO 68 or SAE 20W non-detergent oil or similar lubricant directly on the following areas each time you use your mill (see **Figure 27**):

- Cross slide and saddle ways
- Quill shaft

Apply a light weight lithium based grease directly to these points once a month or more frequently as needed:

- Longitudinal leadscrew (**Figure 28**)
- Crossfeed leadscrew (**Figure 29**)

Note: *Pry up the leadscrew cover to access the crossfeed leadscrew.*

NOTICE

Lack of lubrication causes poor machine performance. Keep your mill lubricated to reduce wear on parts and discourage oxidation.

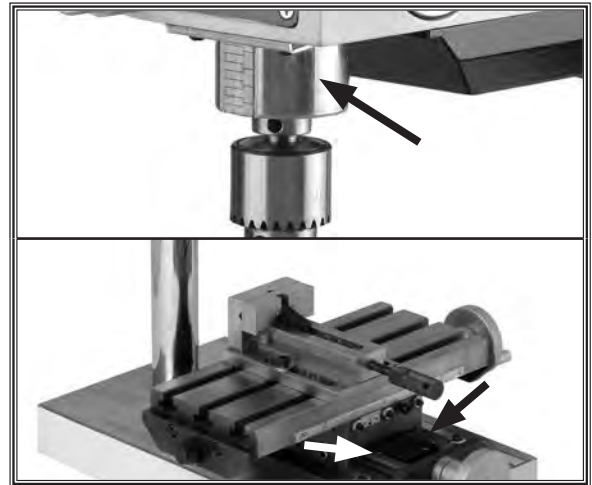

Figure 27. Points of lubrication.

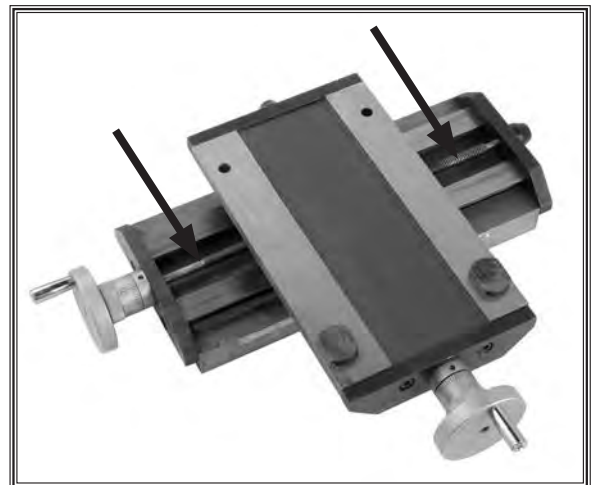

Figure 28. Longitudinal leadscrew.

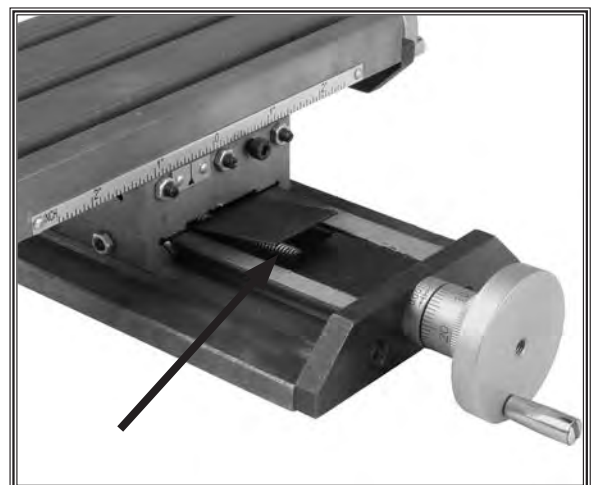

Figure 29. Crossfeed leadscrew.

SERVICE

General

This section covers the most common service adjustments or procedures that may need to be made during the life of your machine.

If you require additional machine service not included in this section, please contact Woodstock International Technical Support at (360) 734-3482 or send e-mail to: tech-support@shopfox.biz.

Gibs

The gibs are pre-adjusted at the factory and should not need further adjustment until many hours of machine use, if ever. If the movement seems too tight, make sure that the locks are fully released, ways are free of chips and debris and are thoroughly lubricated with oil.

When adjusting the gibs, the goal is to take out unnecessary play in the table without causing the slides to bind. Loose gibs may cause poor finishes on the workpiece and may cause undue wear on the slide. Over-tightening may cause binding and premature wear to the gib.

Each gib has multiple lock nuts and set screws that need to be adjusted. Make your adjustments equally and in small increments.

To adjust the gibs, do these steps:

1. UNPLUG THE MICRO MILL!
2. Loosen the lock nuts as shown in Figure 31.
3. Move the table back-and-forth, while slightly tightening each set screw. When properly adjusted, the gib should offer slight resistance without binding.
4. Tighten the lock nuts.

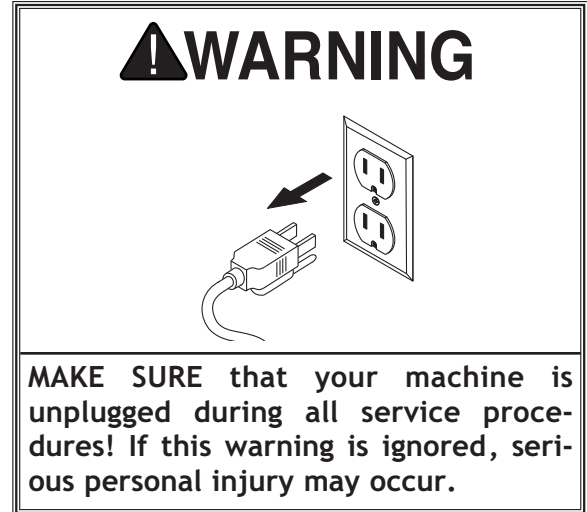

Figure 30. Always unplug before servicing.



Figure 31. Longitudinal gib screw.

Replacing Motor Brushes

After some period of time, the carbon brushes on the DC motor will need to be replaced. Always replace the brushes in pairs.

To replace the motor brushes, do these steps:

1. UNPLUG THE MICRO MILL!
2. Remove the lower motor cover (see **Figure 32**) to expose the motor.
3. Unscrew the cap from the motor housing (see **Figure 33**).
4. Remove the spring and carbon brush, and replace with a new spring and carbon brush.
5. Screw the cap back into the motor housing.

Fuse Replacement

A fuse is located in the switch housing near the RPM dial.

To replace the fuse, do these steps:

1. Loosen the fuse cap.
2. Remove and replace the fuse from the fuse cradle (see **Figure 34**).
3. Replace the fuse cap.



Figure 32. Lower motor cover.

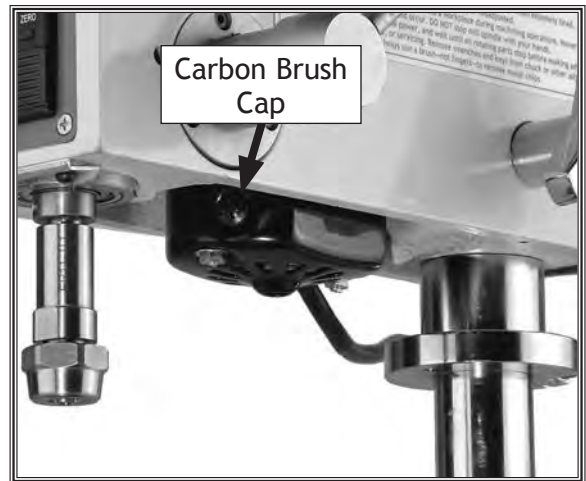
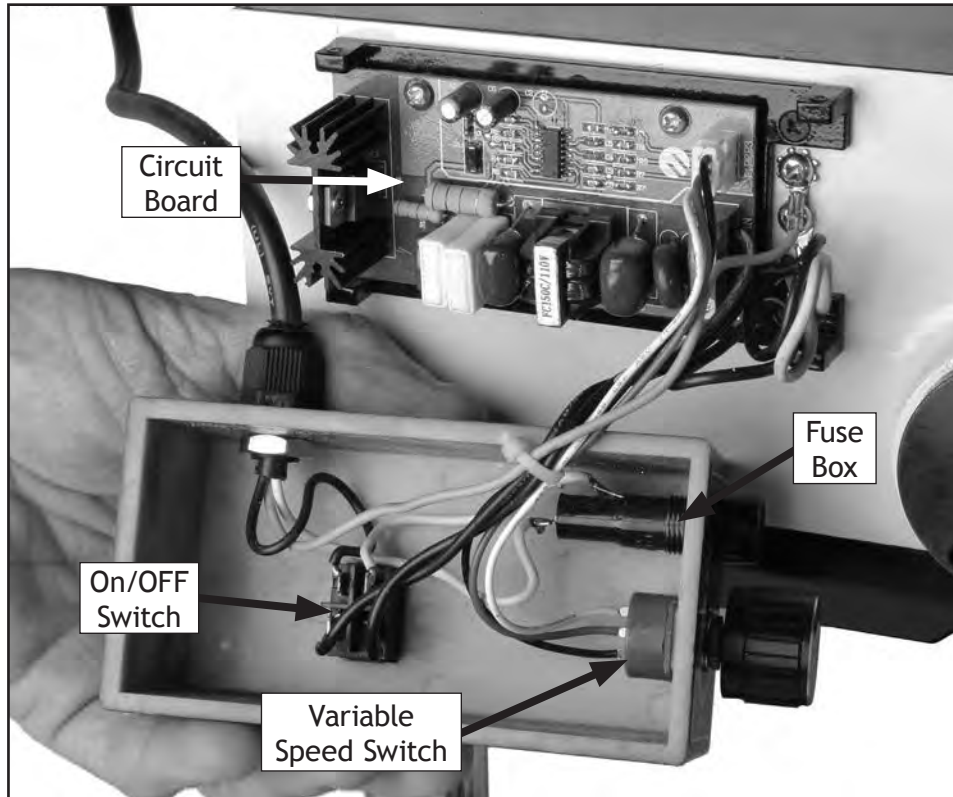

Figure 33. Carbon brush removal.

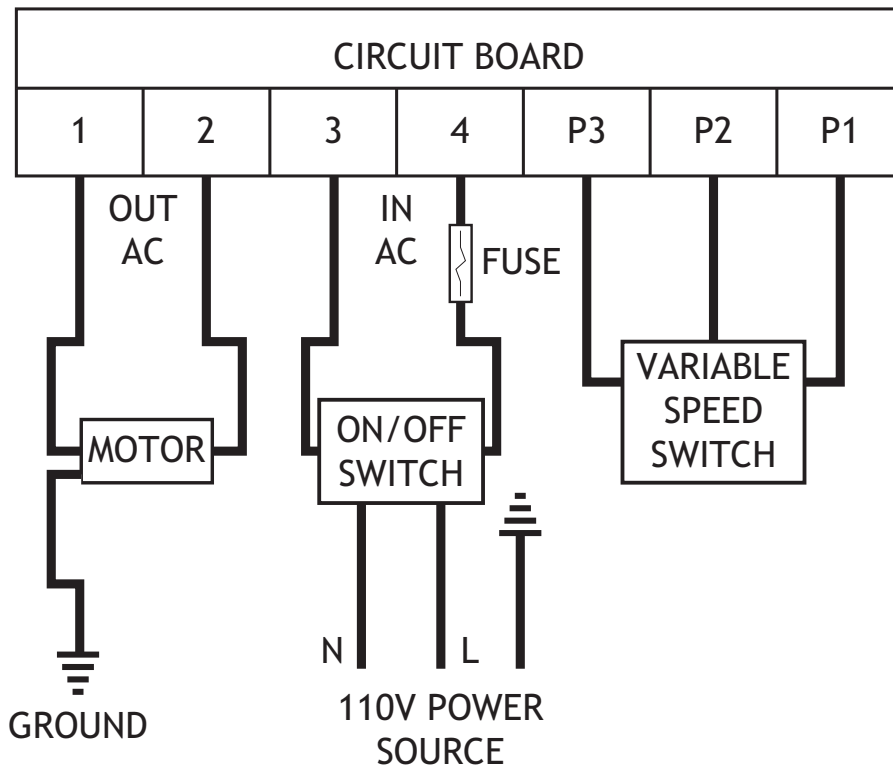

Figure 34. Fuse replacement.

Electrical Components



Wiring Diagram



Troubleshooting

This section covers the most common problems and corrections with this type of machine. **WARNING! DO NOT** make any adjustments until power is disconnected and moving parts have come to a complete stop!

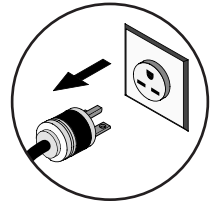

SYMPTOM	POSSIBLE CAUSE	CORRECTIVE ACTION
Motor will not start.	<ol style="list-style-type: none"> 1. Blown system fuse. 2. Tripped circuit breaker inside power source breaker box. 3. Low voltage. 4. Open circuit in motor or loose connections. 5. Switch at fault. 	<ol style="list-style-type: none"> 1. Replace fuse. 2. Reset circuit breaker by flipping switch on then off then back on. 3. Check power supply for proper voltage. 4. Inspect all lead connections on motor and magnetic switch for loose or open connections. 5. Replace switch.
Fuses or circuit breakers trip open.	<ol style="list-style-type: none"> 1. Short circuit in line cord or plug. 2. Short circuit in motor or loose connections. 3. Incorrect fuses or circuit breakers in power supply. 	<ol style="list-style-type: none"> 1. Inspect cord or plug for damaged insulation and shorted wires and replace extension cord. 2. Inspect all connections on motor for loose or shorted terminals or worn insulation. 3. Install correct fuses or circuit breakers.
Motor overheats.	<ol style="list-style-type: none"> 1. Motor overloaded. 2. Air circulation through the motor restricted. 3. Motor brushes are wearing. 	<ol style="list-style-type: none"> 1. Reduce load on motor. 2. Clean out motor to provide normal air circulation. 3. Inspect motor brushes, replace if necessary.
Bit slips in collet or drill chuck.	<ol style="list-style-type: none"> 1. Chuck is not fully tightened. 2. Bit installed in drill chuck off center. 3. Wrong size collet. 4. Debris in collet or in spindle taper. 5. Taking too big of a cut. 	<ol style="list-style-type: none"> 1. Tighten the collet or drill chuck. 2. Re-install bit in drill chuck. 3. Measure tool shank diameter and match with appropriate diameter collet. 4. Remove all oil and debris from collet and spindle taper. 5. Lessen depth of cut and allow chips to clear.
Breaking tools or cutters.	<ol style="list-style-type: none"> 1. RPM and or feed rate is too fast. 2. Cutting tool getting too hot. 3. Taking too big of a cut. 	<ol style="list-style-type: none"> 1. Reduce RPM and feed rates. 2. Use cutting fluid or oil for appropriate application. 3. Lessen depth of cut and allow chips to clear.
Machine is loud when cutting. Overheats or bogs down in the cut.	<ol style="list-style-type: none"> 1. Excessive depth of cut. 2. Dull cutting tools. 	<ol style="list-style-type: none"> 1. Decrease depth of cut. 2. Use sharp cutting tools.
Workpiece vibrates or chatters during operation.	<ol style="list-style-type: none"> 1. Table locks not tight. 2. Workpiece not securely clamped to table or into mill vise. 3. RPM and feed rate too high. 	<ol style="list-style-type: none"> 1. Tighten down table locks. 2. Check that clamping is tight and sufficient for the job. Make sure mill vise is tight to the table. 3. Use appropriate RPM and feed for the job.
Table hard to move.	<ol style="list-style-type: none"> 1. Table locks are tightened down. 2. Chips have loaded up on bedways. 3. Bedways are dry and in need of lubrication. 4. Gibs are too tight. 	<ol style="list-style-type: none"> 1. Make sure table locks are fully released. 2. Frequently clean away chips that load up during milling operations. 3. Lubricate bedways and handles. 4. Loosen gib screw(s).
Bad surface finish.	<ol style="list-style-type: none"> 1. Wrong RPM or feed rate. 2. Dull cutting tool or poor cutting tool selection. 3. Table locks not tightened down. 4. Gibs are loose. 	<ol style="list-style-type: none"> 1. Adjust for appropriate RPM and feed rate. 2. Sharpen cutting tool or select a better cutting tool for the intended operation. 3. Tighten table locks to maintain rigidity. 4. Tighten gibs slightly.
Difficulty removing collet from spindle.	<ol style="list-style-type: none"> 1. Debris in spindle taper or collet taper or both. 	<ol style="list-style-type: none"> 1. Keep all taper surfaces spotlessly clean.

PARTS

WARNING!
Read and understand the instructions and safety warnings before operating the machine. Do not use the machine if you are under the influence of alcohol, drugs, or other substances that impair your judgment. Do not use the machine if you are tired or distracted. Do not use the machine if you are wearing loose clothing or jewelry. Do not use the machine if you are wearing gloves. Do not use the machine if you are wearing contact lenses. Do not use the machine if you are wearing a hearing aid. Do not use the machine if you are wearing a medical device. Do not use the machine if you are wearing a prosthetic limb. Do not use the machine if you are wearing a cast. Do not use the machine if you are wearing a brace. Do not use the machine if you are wearing a bandage. Do not use the machine if you are wearing a patch. Do not use the machine if you are wearing a tattoo. Do not use the machine if you are wearing a piercing. Do not use the machine if you are wearing a tattoo. Do not use the machine if you are wearing a piercing. Do not use the machine if you are wearing a tattoo. Do not use the machine if you are wearing a piercing.

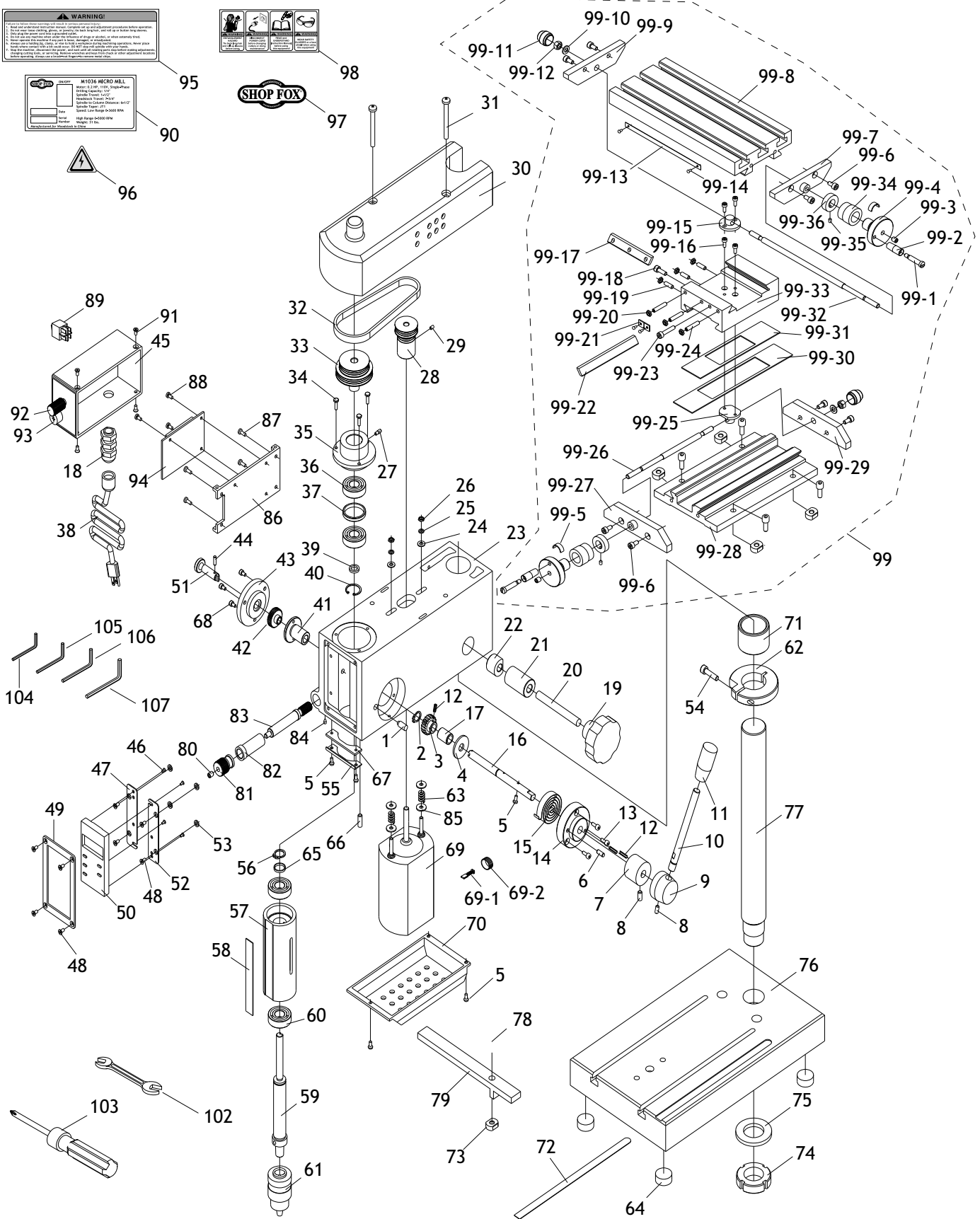

Parts List

REF	PART #	DESCRIPTION
1	XPSS64M	SET SCREW M6-1 X 14
2	XPR39M	EXT RETAINING RING 8MM
3	XM1036003	GEAR
4	XM1036004	SPECIAL WASHER
5	XPS12M	PHLP HD SCR M3-.5 X 6
6	XM1036006	ROUND PIN 4 X 10
7	XM1036007	DIAL RING
8	XPSS31M	SET SCREW M5-.8 X 8
9	XM1036009	HANDLE SEAT
10	XM1036010	HANDLE SHAFT
11	XM1036011	HANDLE KNOB M8-1.25
12	XPRP61M	ROLL PIN 3 X 12
13	XPSB93M	CAP SCREW M3-.5 X 14
14	XM1036014	SPRING SEAT
15	XM1036015	WOUND SPRING
16	XM1036016	SHAFT
17	XM1036017	SPACER
18	XM1036018	STRAIN RELIEF
19	XM1036019	LOCK KNOB
20	XM1036020	STUD M8-1.25
21	XM1036021	FIXTURE BLOCK (I)
22	XM1036022	FIXTURE BLOCK (II)
23	XM1036023	HEAD STOCK
24	XPW05M	FLAT WASHER 4MM
25	XPLW02M	LOCK WASHER 4MM
26	XPN04M	HEX NUT M4-.7
27	XM1036027	LOCKING PIN
28	XM1036028	SMALL PULLEY
29	XPSS08M	SET SCREW M4-.7 X 5
30	XM1036030	UPPER COVER
31	XPS87M	PHLP HD SCR M5-.8 X 45
32	XM1036032	ROUND BELT
33	XM1036033	BIG PULLEY
34	XPB97M	HEX BOLT M4-.7 X 12
35	XM1036035	BEARING SEAT
36	XP6001	BALL BEARING 6001ZZ
37	XM1036037	SPACER
38	XPWRCD110L	POWER CORD

REF	PART #	DESCRIPTION
39	XM1036039	SPACER
40	XPR20M	INT RETAINING RING 28MM
41	XM1036041	HUB
42	XM1036042	GEAR
43	XM1036043	COVER
44	XM1036044	ROUND PIN 3 X 10
45	XM1036045	ELECTRICAL BOX (I)
46	XM1036046	FLAT HD SCR M2-.4 X 6
47	XM1036047	CONNECTING PLATE (LEFT)
48	XPFH49M	FLAT HD SCR M3-.5 X 6
49	XM1036049	PLATE
50	XM1036050	DIGITAL READ OUT
51	XM1036051	CLUTCH KNOB
52	XM1036052	CONNECTING PLATE (RIGHT)
53	XM1036053	RUBBER WASHER
54	XPSB15M	CAP SCREW M5-.8 X 20
55	XM1036055	DUST PLATE
56	XPR05M	EXT RETAINING RING 15MM
57	XM1036057	SPINDLE SLEEVE
58	XM1036058	INDUCTIVE PLATE
59	XM1036059	SPINDLE
60	XP6002	BALL BEARING 6002
61	XM1036061	CHUCK JT1
62	XM1036062	LOCK RING
63	XM1036063	COMPRESSION SPRING
64	XM1036064	RUBBER FOOT
65	XM1036065	SPACER
66	PSS34M	SET SCREW M5-.8 X 16
67	XM1036067	FELT DUSTER
68	XPSB125M	CAP SCREW M3-.5 X 5
69	XM1036069	MOTOR
69-1	XM1036069-1	CARBON MOTOR BRUSH
69-2	XM1036069-2	BRUSH CAP
70	XM1036070	BOTTOM COVER
71	XM1036071	SPACER
72	XM1036072	RULER
73	XM1036073	SQUARE NUT M5-.8
74	XM1036074	SPANNER NUT M24-3 X 1.5

REF	PART #	DESCRIPTION
75	XM1036075	FLAT WASHER 24MM
76	XM1036076	BASE
77	XM1036077	COLUMN
78	XPSB33M	CAP SCREW M5-.8 X 12
79	XM1036079	PARALLEL BAR
80	XPSS26M	SET SCREW M5-.8 X 6
81	XM1036081	SMALL WHEEL
82	XM1036082	SPACER
83	XM1036083	WORM SHAFT
84	XPSS08M	SET SCREW M4-.7 X 5
85	XPW05M	FLAT WASHER 4MM
86	XM1036086	ELECTRICAL BOX BASE
87	XM1036087	FLAT HD SCR M3-.5 X 8
88	XPS12M	PHLP HD SCR M3-.5 X 6
89	XM1036089	POWER SWITCH
90	XM1036090	MACHINE ID LABEL
91	XM1036091	TAP SCREW M3-.5 X 6
92	XM1036092	VARIABLE SPEED CONTROL KNOB
93	XM1036093	FUSE BOX
94	XM1036094	PC BOARD
95	XM1036095	WARNING LABEL
96	XLABEL04	ELECTRICITY LABEL
97	XM1036097	SHOP FOX LOGO LABEL
98	XM1036098	WARNING ICON LABEL
99	XM1036099	COMPOUND SLIDE ASSEMBLY
99-1	XM1036099-1	HANDLE SCREW M4-.7 X 8
99-2	XM1036099-2	HANDLE
99-3	XPSS26M	SET SCREW M5-.8 X 6
99-4	XM1036099-4	HANDWHEEL
99-5	XM1036099-5	FLAT SPRING
99-6	XPSB18M	CAP SCREW M4-.7 X 8
99-7	XM1036099-7	RIGHT SUPPORT SEAT
99-8	XM1036099-8	WORKTABLE
99-9	XM1036099-9	LEADSCREW SUPPORT SEAT
99-10	XPW02M	FLAT WASHER 5MM

REF	PART #	DESCRIPTION
99-11	XM1036099-11	END COVER
99-12	XPN06M	HEX NUT M5-.8
99-13	XM1036099-13	POSITION GAUGE
99-14	XM1036099-14	RIVET
99-15	XM1036099-15	LONGITUDINAL LEADSCREW NUT
99-16	XPSB80M	CAP SCREW M3-.5 X 8
99-17	XM1036099-17	LONGITUDINAL WEDGE
99-18	XPSB23M	CAP SCREW M4-.7 X 12
99-19	XPSS22M	SET SCREW M4-.7 X 12
99-20	XPN04M	HEX NUT M4-.7
99-21	XM1036099-21	INDICATOR PLATE
99-22	XM1036099-22	CROSS WEDGE
99-23	XPSB39M	CAP SCREW M4-.7 X 20
99-24	XPSS50M	SET SCREW M4-.7 X 20
99-25	XM1036099-25	CROSS LEADSCREW NUT
99-26	XM1036099-26	CROSS LEADSCREW
99-27	XM1036099-27	FRONT SUPPORTING SEAT
99-28	XM1036099-28	BASE
99-29	XM1036099-29	SUPPORT SEAT
99-30	XM1036099-30	COVER 1
99-31	XM1036099-31	COVER 2
99-32	XM1036099-32	LONGITUDINAL LEADSCREW
99-33	XM1036099-33	SADDLE
99-34	XM1036099-34	DIAL
99-35	XPSS45M	SET SCREW M3-.5 X 6
99-36	XM1036099-36	GRADUATED DIAL
99-37	XPCAP06M	CAP SCREW M6-1 X 25
99-38	XM1036099-38	T-NUT M6-1
102	XM1036102	DOUBLE END WRENCH 5.5 X 7MM
103	XPSDP2	#2 PHILLIPS SCREWDRIVER
104	XPAW02M	HEX WRENCH 2MM
105	XPAW02.5M	HEX WRENCH 2.5MM
106	XPAW03M	HEX WRENCH 3MM
106	XPAW04M	HEX WRENCH 4MM



Warranty Registration

Name _____
 Street _____
 City _____ State _____ Zip _____
 Phone # _____ Email _____ Invoice # _____
 Model # _____ Serial # _____ Dealer Name _____ Purchase Date _____

The following information is given on a voluntary basis. It will be used for marketing purposes to help us develop better products and services. Of course, all information is strictly confidential.

1. How did you learn about us?

<input type="checkbox"/> Advertisement	<input type="checkbox"/> Friend	<input type="checkbox"/> Local Store
<input type="checkbox"/> Mail Order Catalog	<input type="checkbox"/> Website	<input type="checkbox"/> Other:

2. How long have you been a woodworker/metalworker?

<input type="checkbox"/> 0-2 Years	<input type="checkbox"/> 2-8 Years	<input type="checkbox"/> 8-20 Years	<input type="checkbox"/> 20+ Years
------------------------------------	------------------------------------	-------------------------------------	------------------------------------

3. How many of your machines or tools are Shop Fox?

<input type="checkbox"/> 0-2	<input type="checkbox"/> 3-5	<input type="checkbox"/> 6-9	<input type="checkbox"/> 10+
------------------------------	------------------------------	------------------------------	------------------------------

4. Do you think your machine represents a good value? Yes No

5. Would you recommend Shop Fox products to a friend? Yes No

6. What is your age group?

<input type="checkbox"/> 20-29	<input type="checkbox"/> 30-39	<input type="checkbox"/> 40-49
<input type="checkbox"/> 50-59	<input type="checkbox"/> 60-69	<input type="checkbox"/> 70+

7. What is your annual household income?

<input type="checkbox"/> \$20,000-\$29,000	<input type="checkbox"/> \$30,000-\$39,000	<input type="checkbox"/> \$40,000-\$49,000
<input type="checkbox"/> \$50,000-\$59,000	<input type="checkbox"/> \$60,000-\$69,000	<input type="checkbox"/> \$70,000+

8. Which of the following magazines do you subscribe to?

<input type="checkbox"/> Cabinet Maker	<input type="checkbox"/> Popular Mechanics	<input type="checkbox"/> Today's Homeowner
<input type="checkbox"/> Family Handyman	<input type="checkbox"/> Popular Science	<input type="checkbox"/> Wood
<input type="checkbox"/> Hand Loader	<input type="checkbox"/> Popular Woodworking	<input type="checkbox"/> Wooden Boat
<input type="checkbox"/> Handy	<input type="checkbox"/> Practical Homeowner	<input type="checkbox"/> Woodshop News
<input type="checkbox"/> Home Shop Machinist	<input type="checkbox"/> Precision Shooter	<input type="checkbox"/> Woodsmith
<input type="checkbox"/> Journal of Light Cont.	<input type="checkbox"/> Projects in Metal	<input type="checkbox"/> Woodwork
<input type="checkbox"/> Live Steam	<input type="checkbox"/> RC Modeler	<input type="checkbox"/> Woodworker West
<input type="checkbox"/> Model Airplane News	<input type="checkbox"/> Rifle	<input type="checkbox"/> Woodworker's Journal
<input type="checkbox"/> Modeltec	<input type="checkbox"/> Shop Notes	<input type="checkbox"/> Other:
<input type="checkbox"/> Old House Journal	<input type="checkbox"/> Shotgun News	

9. Comments: _____

CUT ALONG DOTTED LINE

FOLD ALONG DOTTED LINE

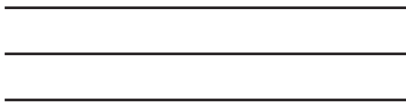

Place
Stamp
Here



WOODSTOCK INTERNATIONAL INC.
P.O. BOX 2309
BELLINGHAM, WA 98227-2309



FOLD ALONG DOTTED LINE

TAPE ALONG EDGES--PLEASE DO NOT STAPLE

WARRANTY

Woodstock International, Inc. warrants all Shop Fox machinery to be free of defects from workmanship and materials for a period of two years from the date of original purchase by the original owner. This warranty does not apply to defects due directly or indirectly to misuse, abuse, negligence or accidents, lack of maintenance, or reimbursement of third party expenses incurred.

Woodstock International, Inc. will repair or replace, at its expense and at its option, the Shop Fox machine or machine part, which in normal use has proven to be defective, provided that the original owner returns the product prepaid to a Shop Fox factory service center with proof of their purchase of the product within two years, and provides Woodstock International, Inc. reasonable opportunity to verify the alleged defect through inspection. If it is determined there is no defect, or that the defect resulted from causes not within the scope of Woodstock International Inc.'s warranty, then the original owner must bear the cost of storing and returning the product.

This is Woodstock International, Inc.'s sole written warranty and any and all warranties that may be implied by law, including any merchantability or fitness, for any particular purpose, are hereby limited to the duration of this written warranty. We do not warrant that Shop Fox machinery complies with the provisions of any law or acts. In no event shall Woodstock International, Inc.'s liability under this warranty exceed the purchase price paid for the product, and any legal actions brought against Woodstock International, Inc. shall be tried in the State of Washington, County of Whatcom. We shall in no event be liable for death, injuries to persons or property or for incidental, contingent, special or consequential damages arising from the use of our products.

Every effort has been made to ensure that all Shop Fox machinery meets high quality and durability standards. We reserve the right to change specifications at any time because of our commitment to continuously improve the quality of our products.



High Quality Machines and Tools

Woodstock International, Inc. carries thousands of products designed to meet the needs of today's woodworkers and metalworkers.

Ask your dealer about these fine products:

BROSENA
PRECISION STOP BLOCK

JOINTER PAL[®]

Rotacator[®]

THE REBEL[®]

DURASTICK[®]

Gutmann[®]

BOARD BUDDIES[®]



Junglee[®]

PLANER PAL[®]

PARROT VISE[®]

SLICKPLANE[®]

PRO-STIK[®]
ABRASIVE BELT & DISC CLEANER

ACCU-SHARP[®]

Aluma-Classic[®]



STEELEX[®]
FINE TOOLS

STEELEX[®]
PLUS



WHOLESALE ONLY

WOODSTOCK INTERNATIONAL, INC.

Phone: (360) 734-3482 • Fax: (360) 671-3053 • Toll Free Fax: (800) 647-8801

P.O.Box 2309 • Bellingham, WA 98227

SHOPFOX.BIZ