



9" X 42" MILLING MACHINE w/POWER FEED

MODEL SB1024 - VARIABLE SPEED, 220V, SINGLE-PHASE

MODEL SB1025 - 220V, 3-PHASE

MODEL SB1026 - 220V, SINGLE-PHASE

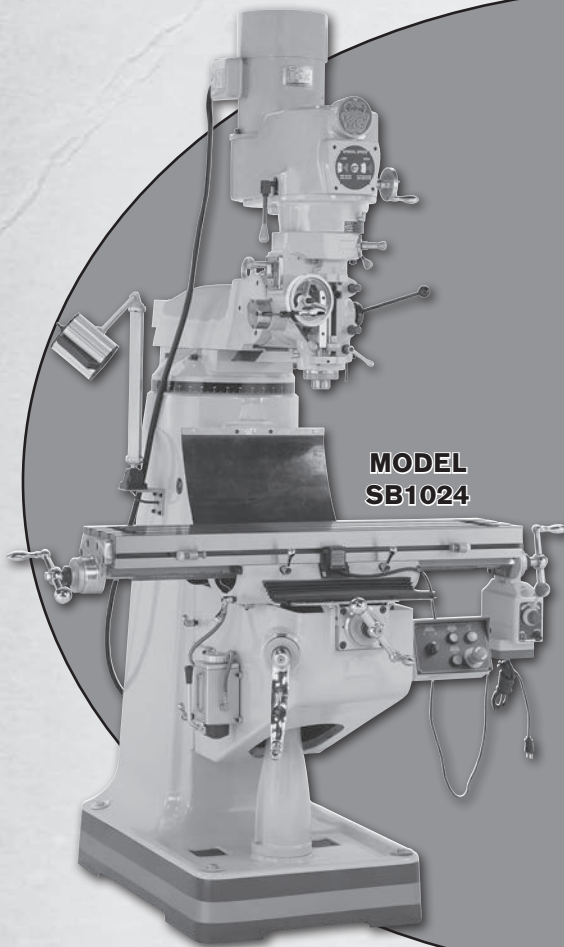

MODEL
SB1024

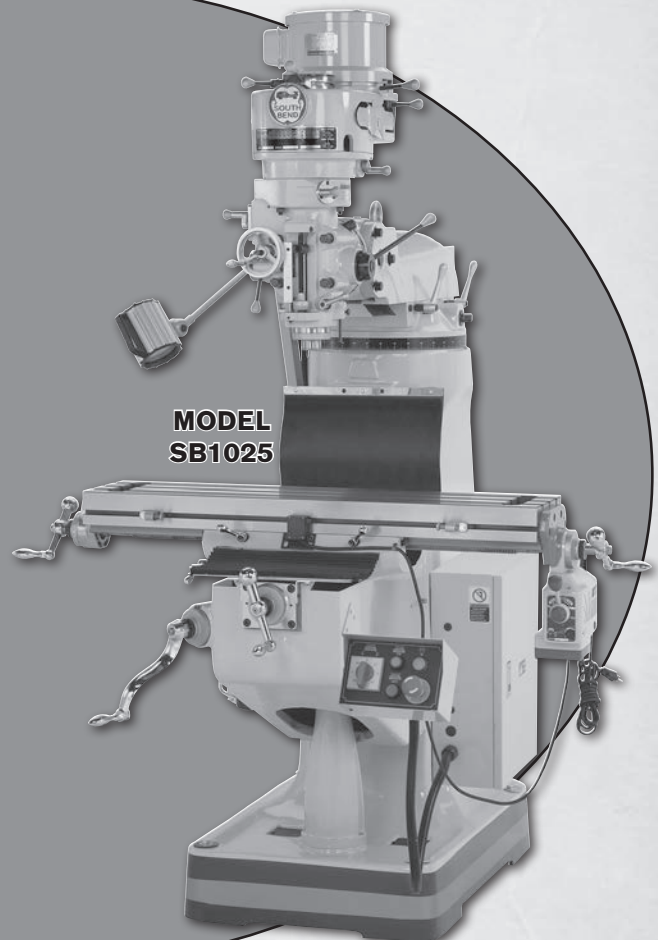

MODEL
SB1025

OWNER'S MANUAL

South Bend Lathe Co.[®]

Hundreds of Thousands of Lathes Sold With a Tradition of Quality Since 1906!



Scope of Manual

This manual helps the reader understand the machine, how to prepare it for operation, how to control it during operation, and how to keep it in good working condition. We assume the reader has a basic understanding of how to operate this type of machine, but that the reader is not familiar with the controls and adjustments of this specific model. As with all machinery of this nature, learning the nuances of operation is a process that happens through training and experience. If you are not an experienced operator of this type of machinery, read through this entire manual, then learn more from an experienced operator, schooling, or research before attempting operations. Following this advice will help you avoid serious personal injury and get the best results from your work.

Manual Feedback

We've made every effort to be accurate when documenting this machine. However, errors sometimes happen or the machine design changes after the documentation process—so the manual may not exactly match your machine. If a difference between the manual and machine leaves you in doubt, contact our customer service for clarification.

We highly value customer feedback on our manuals. If you have a moment, please share your experience using this manual. What did you like about it? Is there anything you would change to make it better? Did it meet your expectations for clarity, professionalism, and ease-of-use?

South Bend Lathe, Inc.
c/o Technical Documentation Manager
P.O. Box 2027
Bellingham, WA 98227
Email: manuals@southbendlathe.com

Updates

For your convenience, any updates to this manual will be available to download free of charge through our website at:

www.southbendlathe.com

Customer Service

We stand behind our machines. If you have any service questions, parts requests or general questions about the machine, feel free to contact us.

South Bend Lathe Co.
P.O. Box 2027
Bellingham, WA 98227
Phone: (360) 734-1540
Parts Department: (417) 886-2954
Fax: (360) 676-1075 (International)
Fax: (360) 734-1639 (USA Only)
Email: cs@southbendlathe.com

Table of Contents

INTRODUCTION

About These Machines.....	3
Foreword.....	3
Capabilities	3
Features.....	3
Front View Identification	4
Model SB1024 Belt Housing & Headstock Identification.....	5
Model SB1025/SB1026 Belt Housing & Headstock Identification.....	6
SB1024 Machine Specifications	7
SB1025 Machine Specifications	9
SB1026 Machine Specifications	11

SAFETY

Understanding Risks of Machinery	13
Basic Machine Safety	13
Additional Milling Machine Safety.....	15

PREPARATION

Preparation Overview.....	16
Things You'll Need.....	16
Unpacking	17
Inventory	17
Cleaning & Protecting	18
Location	19
Electrical Installation	19
Lighting	19
Weight Load	19
Space Allocation	19
Physical Environment.....	19
Lifting & Moving.....	20
Using Eye Bolt	20
Using Lifting Web Straps.....	20
Leveling & Mounting.....	21
Leveling	21
Bolting to Concrete Floors.....	21
Assembly	22
Ball Handles.....	22
Knee Crank	22
Way Covers	23
Power Connection	24
SB1024 (220V).....	24
SB1025 (220V 3-Phase).....	24
SB1026 (220V).....	24

Initial Lubrication	25
Test Run	25
Spindle Break-In.....	27
Inspections & Adjustments	27

OPERATION

Operation Overview.....	28
Control Panel	29
Table Movement.....	29
Graduated Index Rings	30
Table Locks	30
X-Axis Power Feed.....	31
Head Movement	32
Tilting Head	32
Rotating Head	33
Tramming Spindle.....	33
Ram Movement	36
Moving Ram Back-and-Forth	36
Rotating Ram	36
Setting Spindle Speed.....	37
Determining Spindle Speed.....	37
Setting Spindle Speed Range	37
Setting Spindle Speed.....	41
Downfeed Controls.....	43
Using the Coarse Downfeed Handle	43
Fine Downfeed Controls.....	45
Using the Fine Downfeed Handwheel.....	45
Using the Auto-Downfeed System	46
Spindle Brake.....	47
Loading/Unloading Tooling.....	48
Loading Tooling.....	48
Unloading Tooling	48

MAINTENANCE

Maintenance Schedule.....	49
Ongoing.....	49
Before Beginning Operations	49
Daily, After Operations.....	49
Monthly Maintenance Chart.....	50
Cleaning	51
Unpainted & Machined Surfaces.....	51
Lubrication	51
Quill.....	52
Table Ways (One-Shot Oiler).....	52
Speed Range Bearing Sleeve (SB1024 Only)	53
Headstock Gearing	53

Ram Ways 54
 Head & Ram Rack & Pinion Gear 54
 Table Elevation Leadscrew 54
 Power Feed Gears..... 54
 Cleaning Coolant Reservoir..... 56
 Hazards..... 56
 Cleaning..... 56
 Machine Storage 57

SERVICE

Adjusting Gibs..... 58
 Adjusting Leadscrew Backlash 59
 Longitudinal Leadscrew Backlash..... 59
 Cross Leadscrew Backlash 60

TROUBLESHOOTING..... 61

ELECTRICAL

Electrical Safety Instructions 63
 Wiring Overview 64
 SB1024/SB1026 Electrical Box 65
 SB1024/SB1026 Electrical Components 66
 SB1024/SB1026 Electrical Component
 Pictures..... 67

SB1025 Electrical Box 68
 SB1025 Electrical Components..... 69
 SB1025 Electrical Component Pictures..... 70

PARTS

Headstock..... 71
 Quill..... 74
 SB1024 Gearbox..... 75
 SB1025/SB1026 Gearbox..... 77
 SB1024 Belt Housing..... 79
 SB1025/SB1026 Belt Housing..... 81
 Ram..... 83
 Column, Knee, & Saddle 85
 Table 87
 One-Shot Oiler 89
 SB1024/SB1026 Electrical Box 90
 & Control Panel 90
 SB1025 Electrical Box & Control Panel 91
 Accessories 92
 SB1024 Head Machine Labels 93
 SB1024 Main Machine Labels 94
 SB1025/SB1026 Machine Labels 95

WARRANTY & RETURNS..... 97

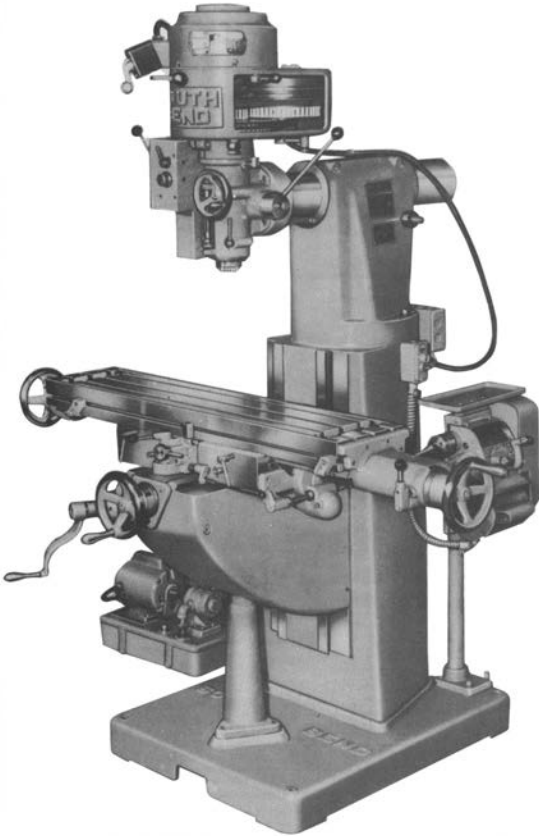

South Bend Vertical Spindle Precision Milling Machine
(circa 1958)

About These Machines

Foreword

"Most boys should learn a trade in order that they may become skilled workmen. The trained workman is always in demand...When a boy has learned a trade, becomes a skilled mechanic, he has excellent equipment with which to begin life's battle, but he need not stop there. George Westinghouse, the Wright Brothers, Henry Ford, and the Studebaker Brothers were mechanics, and it was their mechanical training that made their success possible." —**Machine Shop Equipment**, 2nd Ed., 1920, by the O'Brien Brothers, founders of South Bend Lathe.

The first South Bend milling machine debuted in the 1950's. During that time, the milling machine and the already well-established South Bend lathes created the foundation of many tool rooms and school shops across America and beyond her borders. Many young men in those days came of age on South Bend equipment, becoming world-class machinists, mechanical engineers, inventors, and manufacturing visionaries.

A lot has changed in the world since then. Those same school shops have mostly been replaced by computer labs. The technology in the rotary dial phone, television set, mechanical calculator, computer, and camera of that decade could barely fit into one large room together—now they fit into a tiny box that is no bigger than a box of breath mints. And the average production machinist spends more time at a computer than at a machine. Technology has been much refined and the world operates on a much faster pace.

But some things haven't changed. The same human ingenuity and passion that created the best mechanical technology of today still exists within us. The core machines of the modern shop, like this South Bend milling machine, are still fundamentally important.

When you think about it, the greatest mechanical technology of the future will be what we create today. As the owner of a South Bend milling machine, you are now part of a great legacy. What will you create with yours?

Capabilities

These Milling Machines are built for daily, non-stop use in a busy industrial setting, tool room, or school shop. They are easy to set-up, truly accurate, and built to give you long years of service when properly cared for. These milling machines support workpieces up to 750 lbs. and are perfect for face milling, end milling, planing, slot or keyway cutting, dovetailing, routing, drilling, reaming, and boring to name a few. With the movable ram and tilting head, all these tasks can be performed on horizontal, vertical, and angled surfaces. When equipped with additional accessories, such as a rotary table or dividing head, these milling machines can do even more.

Features

These milling machines feature 3-axis table movement with built-in longitudinal power feed. They are constructed with high-grade Meehanite castings, and the saddle and knee ways are Turcite coated and built with wide dovetails for maximum support and accuracy through the full range of movement.

To ensure quality work results, we have equipped these mills with NSK or NTN spindle bearings that are rated to P4 (ABEC-7) tolerances. The spindle tapers are R8 and the spindles have powered down feed with fine, medium, and coarse feed controls.

The headstocks are mounted on a wide-dovetail movable ram with 13" of travel on the column and 360° rotating capability. The headstocks themselves can swivel 90° left/right or 45° forward/back so they can be positioned for nearly any setup needed.

To reduce the time spent doing daily lubrication, we have outfitted these milling machines with a one-shot lubrication system that is as quick and easy as one pump of a lever.

And finally, each machine is designed to accept a circulating coolant system with room for the pump and reservoir in the column base. Additional features include a movable work light, and Allen Bradley electrical controls.

Front View Identification

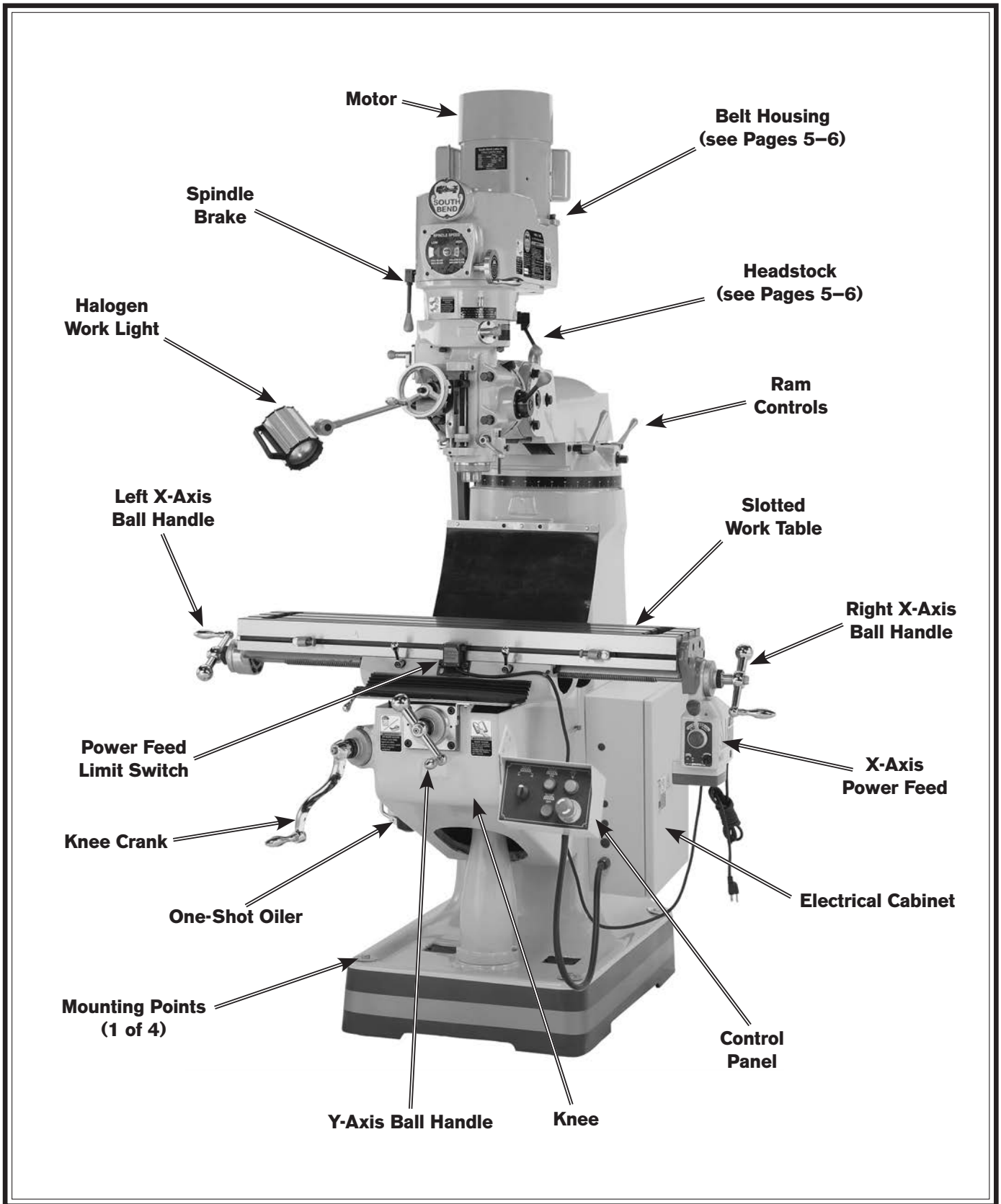

Figure 1. Identification—front view (Model SB1024 shown).

Model SB1024 Belt Housing & Headstock Identification

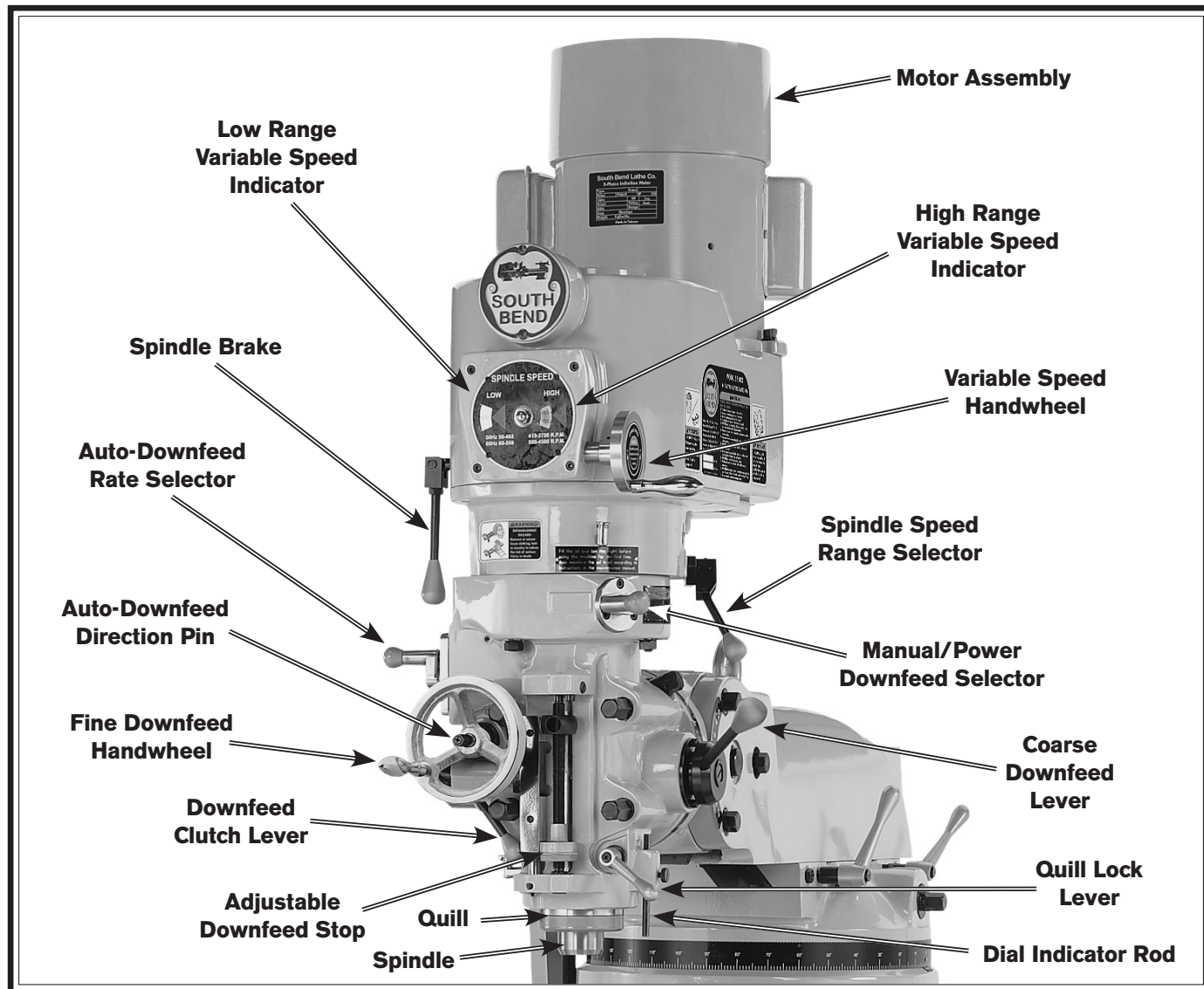

Figure 2. Model SB1024 belt housing and headstock identification.

⚠️ WARNING

Serious personal injury could occur if you connect the machine to power before completing the setup process. **DO NOT** connect power until instructed to do so later in this manual.

⚠️ WARNING

Untrained users have an increased risk of seriously injuring themselves with this machine. Do not operate this machine until you have understood this entire manual and received proper training.

Model SB1025/SB1026 Belt Housing & Headstock Identification

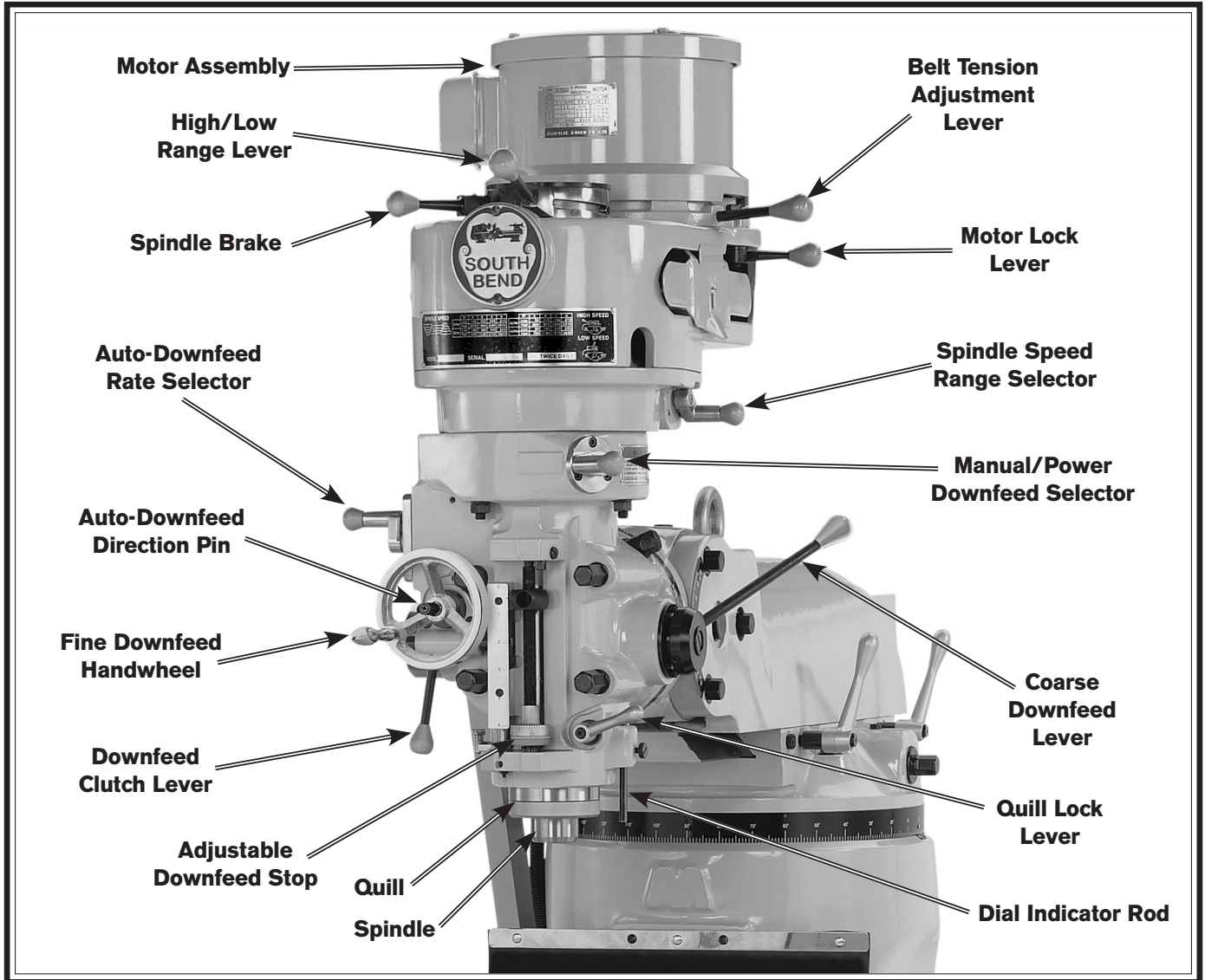

Figure 3. Model SB1025/SB1026 belt housing and headstock identification (Model SB1025 shown).



Model SB1024 Mill 9 x 42 1PH Var.

Product Dimensions

Weight.....	2000 lbs.
Width (side-to-side) x Depth (front-to-back) x Height.....	63 x 58 x 87 in.
Footprint (Length x Width).....	36 x 24 in.
Space Required for Full Range of Movement (Width x Depth).....	81-1/2 x 66 in.

Shipping Dimensions

Type.....	Wood Crate
Content.....	Machine
Weight.....	1984 lbs.
Length x Width x Height.....	54 x 54 x 73 in.

Electrical

Power Requirement.....	220V, Single-Phase, 60 Hz
Prewired Voltage.....	220V
Full-Load Current Rating.....	14A
Minimum Circuit Size.....	20A
Connection Type.....	Cord & Plug
Power Cord Included.....	No
Recommended Power Cord.....	"S"-Type, 3-Wire, 14 AWG, 300 VAC
Plug Included.....	No
Recommended Plug Type.....	6-20
Switch Type.....	Control Panel w/Magnetic Switch Protection

Motors

Main

Horsepower.....	2 HP
Phase.....	Single-Phase
Amps.....	14A
Speed.....	1725 RPM
Type.....	AEVF Capacitor-Start Induction
Power Transfer	Belt Drive
Bearings.....	Sealed & Permanently Lubricated
Centrifugal Switch/Contacts Type.....	External

Main Specifications**Operation Info**

Spindle Travel.....	5 in.
Max Distance Spindle to Column.....	19 in.
Max Distance Spindle to Table.....	19 in.
Longitudinal Table Travel (X-Axis).....	24-1/2 in. (29-1/2 in. w/o Power Feed)
Cross Table Travel (Y-Axis).....	13 in.
Vertical Table Travel (Z-Axis).....	16 in.
Ram Travel.....	13 in.
Turret or Column Swivel (Left /Right).....	360 deg.
Head Tilt (Left/Right).....	90 deg.
Head Tilt (Front/Back).....	45 deg.
Drilling Capacity for Cast Iron.....	1 in.
Drilling Capacity for Steel.....	3/4 in.
End Milling Capacity.....	1 in.
Face Milling Capacity.....	4 in.

Table Info

Table Length.....	42 in.
Table Width.....	9 in.
Table Thickness.....	3 in.
Number of T-Slots.....	3
T-Slot Size.....	5/8 in.
T-Slots Centers.....	2-1/2 in.
Number of Longitudinal Feeds.....	Variable
X-Axis Table Power Feed Rate.....	0 – 3.34 FPM
X/Y-Axis Travel per Handwheel Revolution.....	0.200 in.
Z-Axis Travel per Handwheel Revolution.....	0.100 in.

Spindle Info

Spindle Taper.....	R-8
Number of Vertical Spindle Speeds.....	Variable
Range of Vertical Spindle Speeds.....	60 – 4200 RPM
Quill Diameter.....	3.375 in.
Quill Feed Rates.....	0.0015, 0.003, 0.006 in./rev.
Drawbar Thread Size.....	7/16-20
Drawbar Length.....	18-1/2 in.
Spindle Bearings.....	Angular Contact P4 (ABEC7)

Construction

Spindle Housing/Quill.....	Chrome-Plated & Precision-Ground Steel
Table.....	Hardened & Precision-Ground Cast Iron
Head.....	Meehanite Cast Iron
Column/Base.....	Meehanite Cast Iron
Base.....	Cast Iron
Paint Type/Finish.....	Urethane

Other

Country of Origin	Taiwan
Warranty	1 Year
Approximate Assembly & Setup Time	2 Hours
Serial Number Location	ID Label on Column Right Side
Sound Rating	55 dB
ISO 9001 Factory	No
Certified by a Nationally Recognized Testing Laboratory (NRTL)	No



Model SB1025 Mill 9" x 42" 3PH

Product Dimensions

Weight..... 1918 lbs.
 Width (side-to-side) x Depth (front-to-back) x Height..... 63 x 58 x 81 in.
 Footprint (Length x Width)..... 36 x 24 in.
 Space Required for Full Range of Movement (Width x Depth)..... 81-1/2 x 66 in.

Shipping Dimensions

Type..... Wood Crate
 Content..... Machine
 Weight..... 2062 lbs.
 Length x Width x Height..... 54 x 54 x 74 in.

Electrical

Power Requirement..... 220V, 3-Phase, 60 Hz
 Prewired Voltage..... 220V
 Full-Load Current Rating..... 6A
 Minimum Circuit Size..... 15A
 Connection Type..... Cord & Plug
 Power Cord Included..... No
 Recommended Power Cord..... "S"-Type, 4-Wire, 14 AWG, 300 VAC
 Plug Included..... No
 Recommended Plug Type..... NEMA L15-20
 Switch Type..... Control Panel w/Magnetic Switch Protection
 Recommended Phase Converter..... G5844

Motors

Main

Horsepower..... 2 HP
 Phase..... 3-Phase
 Amps..... 6A/5.6A
 Speed..... 3450 / 1725 RPM
 Type..... AEVF Induction
 Power Transfer Belt Drive
 Bearings..... Sealed & Permanently Lubricated
 Centrifugal Switch/Contacts Type..... N/A

Main Specifications**Operation Info**

Spindle Travel.....	5 in.
Max Distance Spindle to Column.....	19 in.
Max Distance Spindle to Table.....	18 in.
Longitudinal Table Travel (X-Axis).....	24-1/2 in. (29-1/2 in. w/o Power Feed)
Cross Table Travel (Y-Axis).....	13 in.
Vertical Table Travel (Z-Axis).....	16 in.
Ram Travel.....	13 in.
Turret or Column Swivel (Left /Right).....	360 deg.
Head Tilt (Left/Right).....	90 deg.
Head Tilt (Front/Back).....	45 deg.
Drilling Capacity for Cast Iron.....	1 in.
Drilling Capacity for Steel.....	3/4 in.
End Milling Capacity.....	1 in.
Face Milling Capacity.....	4 in.

Table Info

Table Length.....	42 in.
Table Width.....	9 in.
Table Thickness.....	3 in.
Number of T-Slots.....	3
T-Slot Size.....	5/8 in.
T-Slots Centers.....	2-1/2 in.
Number of Longitudinal Feeds.....	Variable
X-Axis Table Power Feed Rate.....	0 – 3.34 FPM
X/Y-Axis Travel per Handwheel Revolution.....	0.200 in.
Z-Axis Travel per Handwheel Revolution.....	0.100 in.

Spindle Info

Spindle Taper.....	R-8
Number of Vertical Spindle Speeds.....	16
Range of Vertical Spindle Speeds.....	80 – 5600 RPM
Quill Diameter.....	3.375 in.
Quill Feed Rates.....	0.0015, 0.003, 0.006 in./rev.
Drawbar Thread Size.....	7/16-20
Drawbar Length.....	18-1/2 in.
Spindle Bearings.....	Angular Contact P4 (ABEC-7)

Construction

Spindle Housing/Quill.....	Chrome-Plated & Precision-Ground Steel
Table.....	Hardened & Precision-Ground Cast Iron
Head.....	Meehanite Cast Iron
Column/Base.....	Meehanite Cast Iron
Base.....	Cast Iron
Paint Type/Finish.....	Urethane

Other

Country of Origin	Taiwan
Warranty	1 Year
Approximate Assembly & Setup Time	2 Hours
Serial Number Location	ID Label on Column Right Side
Sound Rating	55 dB
ISO 9001 Factory	No
Certified by a Nationally Recognized Testing Laboratory (NRTL)	No



Model SB1026 Mill 9" x 42" 1PH

Product Dimensions

Weight.....	1940 lbs.
Width (side-to-side) x Depth (front-to-back) x Height.....	63 x 58 x 86 in.
Footprint (Length x Width).....	36 x 24 in.
Space Required for Full Range of Movement (Width x Depth).....	81-1/2 x 66 in.

Shipping Dimensions

Type.....	Wood Crate
Content.....	Machine
Weight.....	2140 lbs.
Length x Width x Height.....	54 x 54 x 73 in.

Electrical

Power Requirement.....	220V, Single-Phase, 60 Hz
Prewired Voltage.....	220V
Full-Load Current Rating.....	14A
Minimum Circuit Size.....	20A
Connection Type.....	Cord & Plug
Power Cord Included.....	No
Recommended Power Cord.....	"S"-Type, 3-Wire, 14 AWG, 300 VAC
Plug Included.....	No
Recommended Plug Type.....	6-20
Switch Type.....	Control Panel w/Magnetic Switch Protection

Motors

Main

Horsepower.....	2 HP
Phase.....	Single-Phase
Amps.....	14A
Speed.....	1725 RPM
Type.....	AEVF Capacitor-Start Induction
Power Transfer	Belt Drive
Bearings.....	Sealed & Permanently Lubricated
Centrifugal Switch/Contacts Type.....	External

Main Specifications**Operation Info**

Spindle Travel.....	5 in.
Max Distance Spindle to Column.....	19 in.
Max Distance Spindle to Table.....	18 in.
Longitudinal Table Travel (X-Axis).....	24-1/2 in. (29-1/2 in. w/o Power Feed)
Cross Table Travel (Y-Axis).....	13 in.
Vertical Table Travel (Z-Axis).....	16 in.
Ram Travel.....	13 in.
Turret or Column Swivel (Left /Right).....	360 deg.
Head Tilt (Left/Right).....	90 deg.
Head Tilt (Front/Back).....	45 deg.
Drilling Capacity for Cast Iron.....	1 in.
Drilling Capacity for Steel.....	3/4 in.
End Milling Capacity.....	1 in.
Face Milling Capacity.....	4 in.

Table Info

Table Length.....	42 in.
Table Width.....	9 in.
Table Thickness.....	3 in.
Number of T-Slots.....	3
T-Slot Size.....	5/8 in.
T-Slots Centers.....	2-1/2 in.
Number of Longitudinal Feeds.....	Variable
X-Axis Table Power Feed Rate.....	0 – 3.34 FPM
X/Y-Axis Travel per Handwheel Revolution.....	0.200 in.
Z-Axis Travel per Handwheel Revolution.....	0.100 in.

Spindle Info

Spindle Taper.....	R-8
Number of Vertical Spindle Speeds.....	8
Range of Vertical Spindle Speeds.....	80 – 2800 RPM
Quill Diameter.....	3.375 in.
Quill Feed Rates.....	0.0015, 0.003, 0.006 in./rev.
Drawbar Thread Size.....	7/16-20
Drawbar Length.....	18-1/2 in.
Spindle Bearings.....	Angular Contact P4 (ABEC-7)

Construction

Spindle Housing/Quill.....	Chrome-Plated & Precision-Ground Steel
Table.....	Hardened & Precision-Ground Cast Iron
Head.....	Meehanite Cast Iron
Column/Base.....	Meehanite Cast Iron
Base.....	Cast Iron
Paint Type/Finish.....	Urethane

Other

Country of Origin	Taiwan
Warranty	1 Year
Approximate Assembly & Setup Time	2 Hours
Serial Number Location	ID Label on Column Right Side
Sound Rating	55 dB
ISO 9001 Factory	No
Certified by a Nationally Recognized Testing Laboratory (NRTL)	No



Understanding Risks of Machinery

Operating all machinery and machining equipment can be dangerous or relatively safe depending on how it is installed and maintained, and the operator's experience, common sense, risk awareness, working conditions, and use of personal protective equipment (safety glasses, respirators, etc.).

The owner of this machinery or equipment is ultimately responsible for its safe use. This responsibility includes proper installation in a safe environment, personnel training and usage authorization, regular inspection and maintenance, manual availability and comprehension, application of safety devices, integrity of cutting tools or accessories, and the usage of approved personal protective equipment by all operators and bystanders.

The manufacturer of this machinery or equipment will not be held liable for injury or property damage from negligence, improper training, machine modifications, or misuse. Failure to read, understand, and follow the manual and safety labels may result in serious personal injury, including amputation, broken bones, electrocution, or death.

The signals used in this manual to identify hazard levels are as follows:

 DANGER	<i>Death or catastrophic harm WILL occur.</i>	 CAUTION	<i>Moderate injury or fire MAY occur.</i>
 WARNING	<i>Death or catastrophic harm COULD occur.</i>	NOTICE	<i>Machine or property damage may occur.</i>

Basic Machine Safety

Owner's Manual: All machinery and machining equipment presents serious injury hazards to untrained users. To reduce the risk of injury, anyone who uses THIS item MUST read and understand this entire manual before starting.

Personal Protective Equipment: Operating or servicing this item may expose the user to flying debris, dust, smoke, dangerous chemicals, or loud noises. These hazards can result in eye injury, blindness, long-term respiratory damage, poisoning, cancer, reproductive harm or hearing loss. Reduce your risks from these hazards by wearing approved eye protection, respirator, gloves, or hearing protection.

Trained/Supervised Operators Only: Untrained users can seriously injure themselves or bystanders. Only allow trained and properly supervised personnel to operate this item. Make sure safe operation instructions are clearly understood. If electrically powered, use padlocks and master switches, and remove start switch keys to prevent unauthorized use or accidental starting.

Guards/Covers: Accidental contact with moving parts during operation may cause severe entanglement, impact, cutting, or crushing injuries. Reduce this risk by keeping any included guards/covers/doors installed, fully functional, and positioned for maximum protection.

Entanglement: Loose clothing, gloves, neckties, jewelry or long hair may get caught in moving parts, causing entanglement, amputation, crushing, or strangulation. Reduce this risk by removing/securing these items so they cannot contact moving parts.

Mental Alertness: Operating this item with reduced mental alertness increases the risk of accidental injury. Do not let a temporary influence or distraction lead to a permanent disability! Never operate when under the influence of drugs/alcohol, when tired, or otherwise distracted.

Safe Environment: Operating electrically powered equipment in a wet environment may result in electrocution; operating near highly flammable materials may result in a fire or explosion. Only operate this item in a dry location that is free from flammable materials.

Electrical Connection: With electrically powered equipment, improper connections to the power source may result in electrocution or fire. Always adhere to all electrical requirements and applicable codes when connecting to the power source. Have all work inspected by a qualified electrician to minimize risk.

Disconnect Power: Adjusting or servicing electrically powered equipment while it is connected to the power source greatly increases the risk of injury from accidental startup. Always disconnect power **BEFORE** any service or adjustments, including changing blades or other tooling.

Secure Workpiece/Tooling: Loose workpieces, cutting tools, or rotating spindles can become dangerous projectiles if not secured or if they hit another object during operation. Reduce the risk of this hazard by verifying that all fastening devices are properly secured and items attached to spindles have enough clearance to safely rotate.

Chuck Keys or Adjusting Tools: Tools used to adjust spindles, chucks, or any moving/rotating parts will become dangerous projectiles if left in place when the machine is started. Reduce this risk by developing the habit of always removing these tools immediately after using them.

Work Area: Clutter and dark shadows increase the risks of accidental injury. Only operate this item in a clean, non-glaring, and well-lighted work area.

Properly Functioning Equipment: Poorly maintained, damaged, or malfunctioning equipment has higher risks of causing serious personal injury compared to those that are properly maintained. To reduce this risk, always maintain this item to the highest standards and promptly repair/service a damaged or malfunctioning component. Always follow the maintenance instructions included in this documentation.

Unattended Operation: Electrically powered equipment that is left unattended while running cannot be controlled and is dangerous to bystanders. Always turn the power **OFF** before walking away.

Health Hazards: Certain cutting fluids and lubricants, or dust/smoke created when cutting, may contain chemicals known to the State of California to cause cancer, respiratory problems, birth defects, or other reproductive harm. Minimize exposure to these chemicals by wearing approved personal protective equipment and operating in a well ventilated area.

Difficult Operations: Attempting difficult operations with which you are unfamiliar increases the risk of injury. If you experience difficulties performing the intended operation, **STOP!** Seek an alternative method to accomplish the same task, ask a qualified expert how the operation should be performed, or contact our Technical Support for assistance.

Additional Milling Machine Safety

- 1. Understanding Controls:** The mill is a complex machine that presents severe cutting or amputation hazards if used incorrectly. Make sure you understand the use and operation of all controls before you begin milling.
- 2. Safety Accessories:** Flying chips or debris from the cutting operation can cause eye injury or blindness. Always use a chip guard in addition to your safety glasses or use a face shield when milling.
- 3. Work Holding:** Milling a workpiece that is not properly clamped to the table could cause the workpiece to fly into the operator with deadly force! Before starting the machine, be certain the workpiece has been properly clamped to the table. NEVER hold the workpiece by hand during operation.
- 4. Spindle Speed:** To avoid tool or workpiece breakage that could send flying debris at the operator and bystanders, use the correct spindle speed for the operation. Allow the mill to gain full speed before beginning the cut.
- 5. Spindle Direction Change:** Changing spindle rotation direction while it is spinning could lead to impact injury from broken tool or workpiece debris, and workpiece or machine damage. ALWAYS make sure the spindle is at a complete stop before changing spindle direction.
- 6. Stopping Spindle:** To reduce the risk of hand injuries or entanglement hazards, DO NOT attempt to stop the spindle with your hand or a tool. Allow the spindle to stop on its own or use the spindle brake.
- 7. Chip Cleanup:** Chips from the operation are sharp and hot, which can cause burns or cuts. Using compressed air to clear chips could cause them to fly into your eyes, and may drive them deep into the working parts of the machine. Use a brush or vacuum to clear away chips and debris from the machine or workpiece and NEVER clear chips while the spindle is turning.
- 8. Machine Care & Maintenance:** Operating the mill with excessively worn or damaged machine parts increases the risk of machine or workpiece breakage which could eject hazardous debris at the operator. Operating a mill in poor condition will also reduce the quality of the results. To reduce this risk, maintain the mill in proper working condition by ALWAYS promptly performing routine inspections and maintenance.
- 9. Cutting Tool Usage:** Cutting tools have very sharp leading edges—handle them with care! Using cutting tools that are in good condition helps to ensure quality milling results and reduces the risk of personal injury from broken tool debris. Inspect cutting tools for sharpness, chips, or cracks before each use, and ALWAYS make sure the cutting tools are firmly held in place before starting the machine.

Preparation Overview

The purpose of the preparation section is to help you prepare your machine for operation.

The typical preparation process is as follows:

1. Unpack the machine and inventory the contents of the box/crate.
2. Clean the machine and its components.
3. Identify an acceptable location for the machine and move it to that location.
4. Level the machine and either bolt it to the floor or place it on mounts.
5. Assemble the loose components and make any necessary adjustments or inspections to ensure the machine is ready for operation.
6. Connect the machine to the power source.
7. Test run the machine to make sure it functions properly and is ready for operation.

Things You'll Need

During the setup process, operation, and maintenance of the machine, you'll need the following items:

For Lifting (Page 20)

- A forklift or other power lifting device rated for more than the weight of the machine.
- Two lifting web straps rated for the weight of the machine.
- At least two other persons to help with the operation.

For Power Connection

- We recommend a qualified electrician to ensure a safe and code-compliant connection to the power source. (Refer to **Page 24** for details.)

For Assembly

- Cotton disposable rags
- Cleaner/degreaser (see **Page 18**)
- Safety glasses for each person

Unpacking

This item was carefully packaged to prevent damage during transport. If you discover any damage, please immediately call Customer Service at (360) 734-1540 for advice. You may need to file a freight claim, so save the containers and all packing materials for possible inspection by the carrier or its agent.

Inventory

After all of the parts other than the mill have been removed from the shipping crate, you should have the following inventory.

Description (Figure 4)	Qty
A. Front Way Cover	1
B. Rear Way Cover	1
C. Fine Downfeed Handwheel.....	1
D. Drawbar $\frac{7}{16}$ "-20 x 18 $\frac{1}{2}$ ".....	1
E. Ball Handles (Left Y-Axis, X-Axis)	2
F. Ball Handle (Power Feed).....	1
G. Ball Handle Handles.....	3
H. Oil Bottle	1
I. Tool Box	1
J. Combo Closed-End Wrench 19/21mm.....	1
K. Combo Open-End Wrench 12/14mm.....	1
L. Coarse Downfeed Lever	1
M. Knee Crank	1
N. SB1025/SB1026 Belt Housing Safety Covers	2
O. Hex Wrench Set 1.5–10mm	1
P. Screwdrivers Slotted #2, Phillips #2.....	1 Each

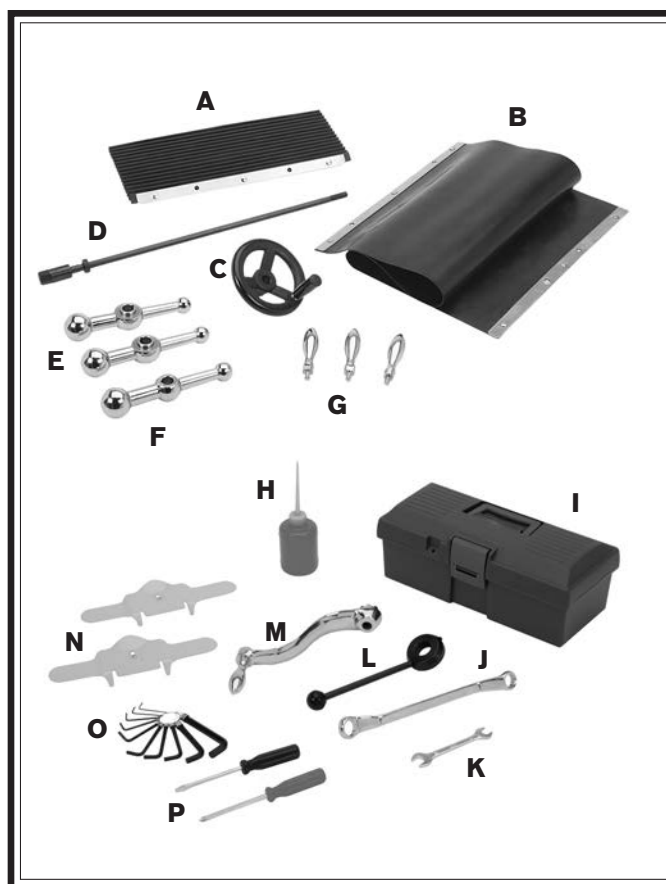

Figure 4. Small part inventory.

Cleaning & Protecting

The unpainted surfaces are coated at the factory with a heavy-duty rust preventative that prevents corrosion during shipment and storage. The benefit of this rust preventative is that it works very well. The downside is that it can be time-consuming to thoroughly remove.

Be patient and do a careful job when cleaning and removing the rust preventative. The time you spend doing this will reward you with smooth-sliding parts and a better appreciation for the proper care of the unpainted surfaces.

Although there are many ways to successfully remove the rust preventative, the following process works well in most situations.

Before cleaning, gather the following:

- Disposable rags
- Cleaner/degreaser (certain citrus-based degreasers work extremely well and they have non-toxic fumes)
- Safety glasses & disposable gloves

Note: Automotive degreasers, mineral spirits, or WD•40 can be used to remove rust preventative. Before using these products, though, test them on an inconspicuous area of a painted surface to make sure they will not damage it.

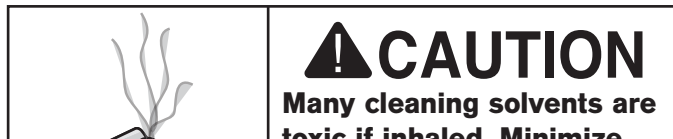
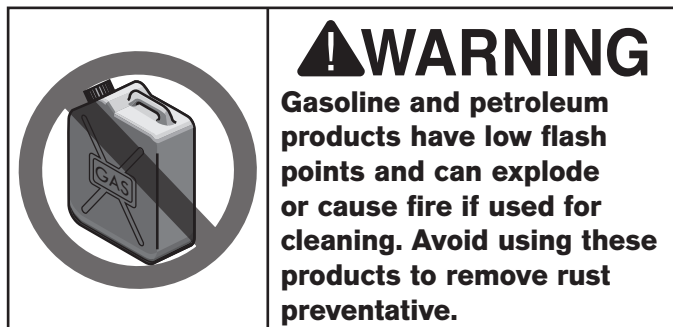

NOTICE

Avoid chlorine-based solvents, such as acetone or brake parts cleaner that may damage painted surfaces. Always follow the manufacturer's instructions when using any type of cleaning product.

Basic steps for removing rust preventative:

1. Put on safety glasses and disposable gloves.
2. Coat all surfaces that have rust preventative with a liberal amount of your cleaner or degreaser and let them soak for a few minutes.
3. Wipe off the surfaces. If your cleaner or degreaser is effective, the rust preventative will wipe off easily.

Note: To clean off thick coats of rust preventative on flat surfaces, such as beds or tables, use a PLASTIC paint scraper to scrape off the majority of the coating before wiping it off with your rag. (Do not use a metal scraper or it may scratch the surface.)

4. Repeat **Steps 2–3** as necessary until clean, then coat all unpainted surfaces with a quality metal protectant or light oil to prevent rust.

Location

Physical Environment

The physical environment where your machine is operated is important for safe operation and longevity of parts. For best results, operate this machine in a dry environment that is free from excessive moisture, hazardous or flammable chemicals, airborne abrasives, or extreme conditions. Extreme conditions for this type of machinery are generally those where the ambient temperature is outside the range of 41°–104°F; the relative humidity is outside the range of 20–95% (non-condensing); or the environment is subject to vibration, shocks, or bumps.

Electrical Installation

Place this machine near an existing power source. Make sure all power cords are protected from traffic, material handling, moisture, chemicals, or other hazards. Make sure to leave access to a means of disconnecting the power source or engaging a lockout/tagout device.

Lighting

Lighting around the machine must be adequate enough to perform operations safely. Shadows, glare, or strobe effects that may distract or impede the operator must be eliminated.

Weight Load

Refer to the **Machine Specifications** for the weight of your machine. Make sure that the surface upon which the machine is placed will bear the weight of the machine, additional equipment that may be installed on the machine, and the heaviest workpiece that will be used. Additionally, consider the weight of the operator and any dynamic loading that may occur when operating the machine.

Space Allocation

Consider the largest size of workpiece that will be processed through this machine and provide enough space around the machine for adequate operator material handling or the installation of auxiliary equipment. With permanent installations, leave enough space around the machine to open or remove doors/covers as required by the maintenance and service described in this manual.



CAUTION

Children or untrained people may be seriously injured by this machine. Only install in an access restricted location.

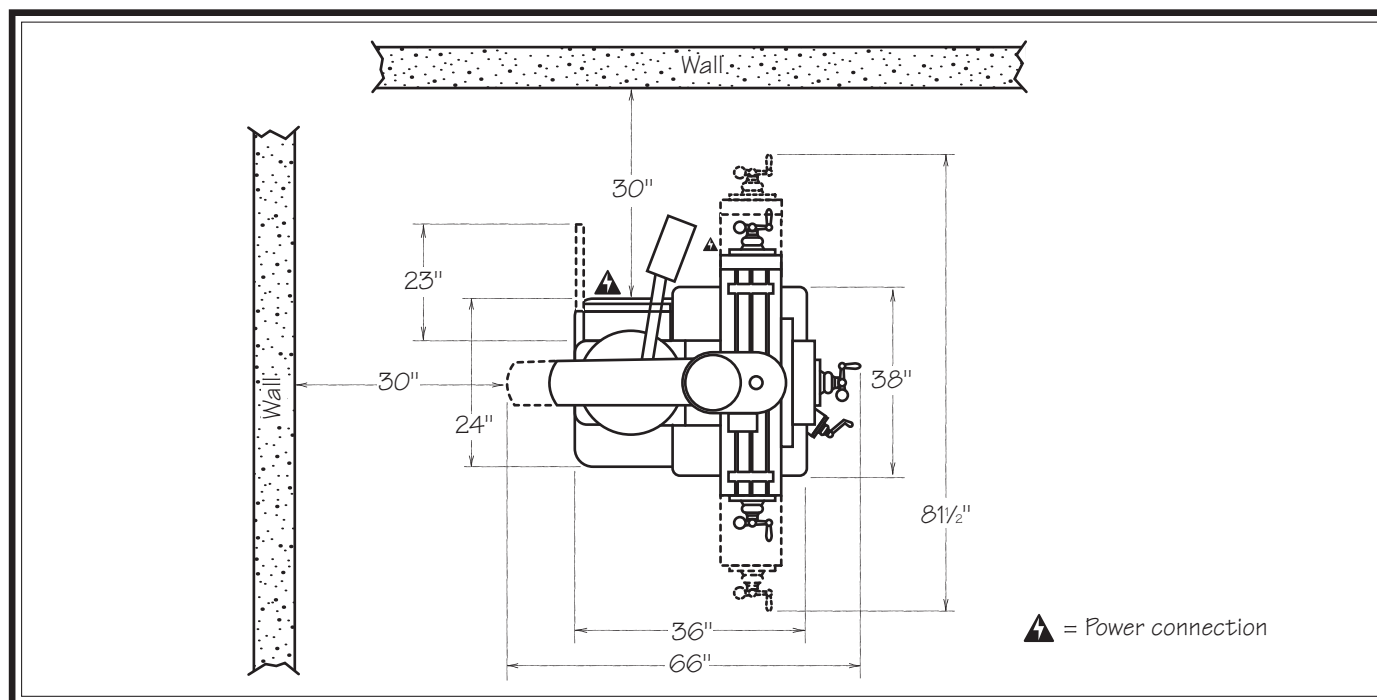
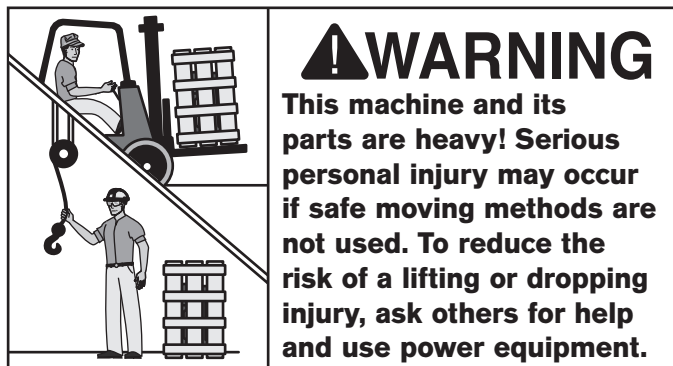

Figure 5. Space required for full range of movement.

Lifting & Moving



The method of lifting and moving the mill described below requires at least two other people for assistance and a forklift with two lifting web straps rated for at least 3000 lbs. each.

Important: Before lifting the mill, make sure the four turret lock bolts (two on either side of the ram) are torqued to 47 ft/lbs.

To lift and move the mill:

1. Swing the ram around 180° from the position that it was shipped in, then rotate the head upright, as illustrated in **Figure 6** (refer to **Ram Movement** on **Page 36** and **Headstock Movement** on **Page 32** for detailed instructions).

Note: After re-positioning the ram and headstock, make sure they are locked in place to prevent unexpected movement during lifting and moving.

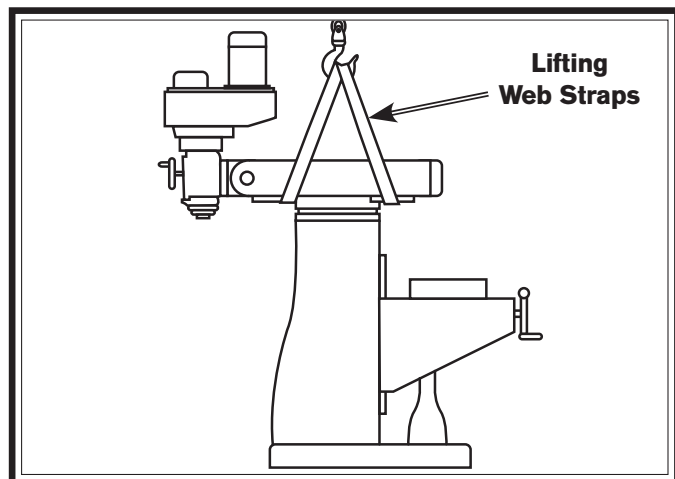

Figure 6. Using web straps to lift the mill.

2. Place the lifting web straps under the ram and connect them to the safety hook, as illustrated in **Figure 6**.

Note: Place padding between the straps and the mill to protect the ram and ways, and to keep from cutting the web straps.

3. Unbolt the mill from the shipping pallet.
4. With your assistants steadying the load to keep it from swaying, lift the mill a couple of inches.

— If the mill tips to one side, lower to the ground and adjust the ram or table to balance the load. Make sure to re-tighten the lock levers and bolts before lifting the mill again.

— If the mill lifts evenly, continue to move it to its permanent location.

Leveling & Mounting

Generally, you can either bolt your machine to the floor or mount it on machine mounts. Although not required, we recommend that you secure the machine to the floor and level it while doing so. Because this is an optional step and floor materials may vary, hardware for securing the machine to the floor is not included.

NOTICE

We strongly recommend securing your machine to the floor if it is hardwired to the power source. Consult with your electrician to ensure compliance with local codes.

Leveling

Leveling machinery helps precision components, such as bed ways, remain straight and flat during the lifespan of the machine. Components on an unlevelled machine may slowly twist due to the dynamic loads placed on the machine during operation.

For best results, use a precision level that is at least 12" long and sensitive enough to show a distinct movement when a 0.003" shim (approximately the thickness of one sheet of standard newspaper) is placed under one end of the level.

See the figure below for an example of a high precision level.

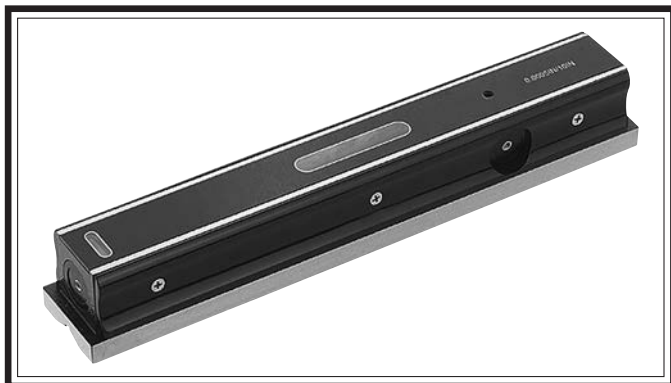

Figure 7. Example of a precision level.

Bolting to Concrete Floors

Lag shield anchors with lag bolts and anchor studs (**below**) are two popular methods for bolting machinery to a concrete floor. We suggest you research the many options and methods for mounting your machine and choose the best that fits your specific application.

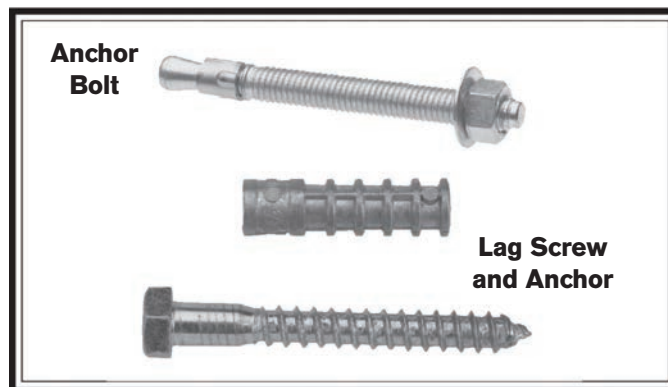

Figure 8. Common types of fasteners for bolting machinery to concrete floors.

Assembly

Ball Handles

The ball handles for either end of the X-axis leadscrew have spring-loaded, keyed center bushings, as shown in **Figure 9**. This allows them to disengage from the leadscrew when using the power feed, avoiding an entanglement hazard.

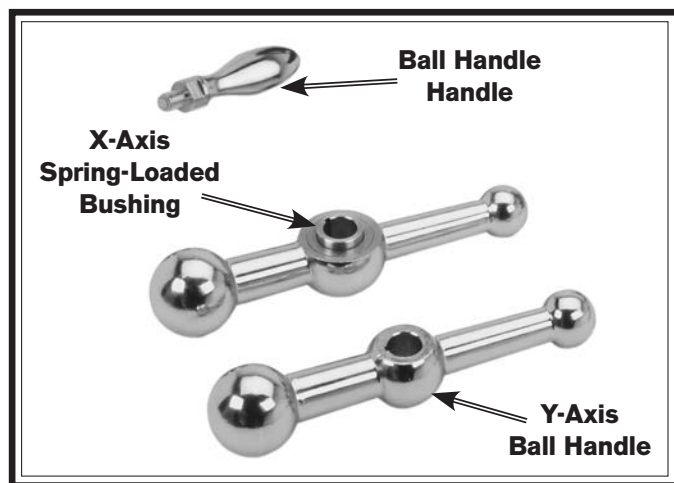

Figure 9. Ball handle assemblies.

To install the ball handles:

1. Remove the hex nuts from both ends of the X-axis leadscrew.
2. Identify the two ball handles with the spring-loaded center bushings (see **Figure 9**).
3. Position the ball handle so that the protruding part of the bushing is facing toward the table, align the keyway with the X-axis leadscrew key, then slide it onto the leadscrew.

4. Secure the ball handles with the hex nuts removed in **Step 1**.

Note: Tighten the hex nuts just until they are snug. Overtightening could increase the wear of the moving parts.

5. Remove the hex nut from the Y-axis leadscrew.
6. Align the keyway of the remaining ball handle with the leadscrew key, slide the Y-axis ball handle (see **Figure 9**) onto the leadscrew, then secure it in place with the removed hex nut.
7. Thread the handles into the small end of the ball handles and tighten them with a wrench.

Knee Crank

Slide the knee crank onto the shaft so that the teeth of the crank and shaft engage, as shown in **Figure 10**.

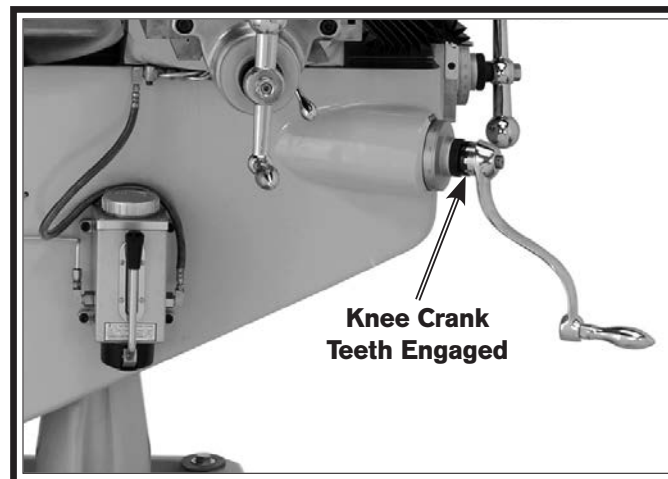

Figure 10. Knee crank and shaft teeth engaged.

Way Covers

1. Remove the five button-head cap screws shown in **Figure 11** from the front of the saddle and knee, position the pleated way cover in place, then secure it with the removed cap screws.

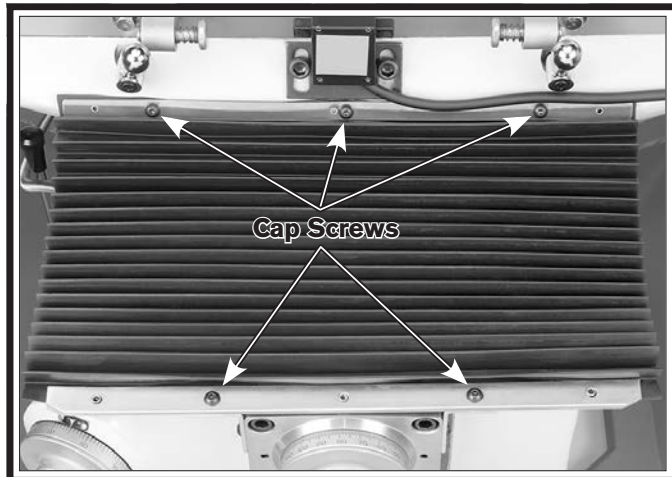

Figure 11. Front way cover installed.

2. Remove the four button-head cap screws shown in **Figure 12** from the column and the rear of the table, position the rear way cover in place, then secure it with the removed cap screws.

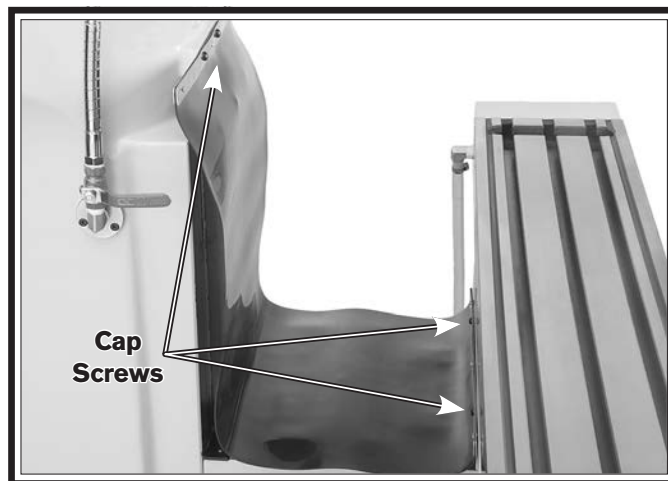
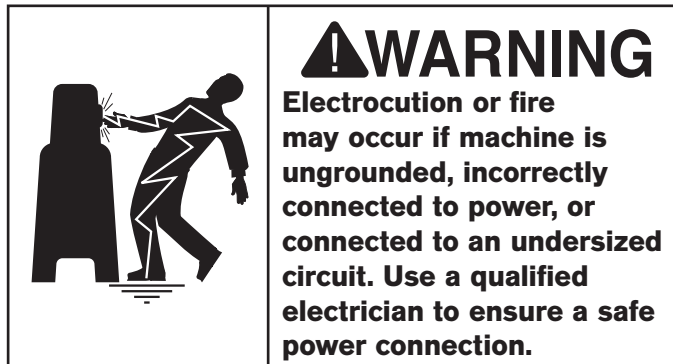

Figure 12. Rear way cover installed.

Power Connection



Once the machine is set up and assembled as previously described in this manual, it is ready to be connected to the power source.

Note About Extension Cords: Using an incorrectly sized extension cord may decrease the life of electrical components on the machine.

Note About 3-Phase Power: DO NOT use a static phase converter to create 3-phase power—it can quickly decrease the life of electrical components on the machine. If you must use a phase converter, only use a rotary phase converter and connect the manufactured leg to the L2 power connection terminal, shown in the wiring diagram on **Page 68**.

SB1024 (220V)

Full Load Amp Draw 14 Amps
 Required Voltage Range 220V
 Phase Single-Phase
 Frequency 60 Hz
 Minimum Circuit Size 20 Amps
 Recommended Power Cord ... 14 AWG/3C/300VAC
 Recommended Plug/Receptacle NEMA 6-20
 Minimum Extension Cord Size 14 AWG
 Maximum Extension Cord Length 50 ft.

SB1025 (220V 3-Phase)

Full Load Amp Draw 6/5.6 Amps
 Required Voltage Range 220V
 Phase 3-Phase
 Frequency 60 Hz
 Minimum Circuit Size 15 Amps
 Recommended Power Cord ... 14 AWG/4C/300VAC
 Recommended Plug/Receptacle NEMA L15-20
 Minimum Extension Cord Size 14 AWG
 Maximum Extension Cord Length 50 ft.

SB1026 (220V)

Full Load Amp Draw 14 Amps
 Required Voltage Range 220V
 Phase Single-Phase
 Frequency 60 Hz
 Minimum Circuit Size 20 Amps
 Recommended Power Cord ... 14 AWG/3C/300VAC
 Recommended Plug/Receptacle NEMA 6-20
 Minimum Extension Cord Size 14 AWG
 Maximum Extension Cord Length 50 ft.

To connect the mill to power:

1. Make sure the incoming power source and the power cord meet the requirements listed above.
2. Use the correct size strain relief when you feed the power cord through the bottom of the electrical cabinet.
3. Terminate the power cord as illustrated in the **Electrical Box Wiring Diagrams on Pages 65–68**.
4. We recommend that you connect the other end to a NEMA 6-20 plug (SB 1024/26) or NEMA L15-20 plug (SB1025).

Initial Lubrication

The machine was fully lubricated at the factory, but we strongly recommend that before performing the **Test Run** you inspect all lubrication points yourself and provide additional lubrication if necessary. Refer to the **Lubrication** section on **Page 51** for specific details.

Test Run

After all preparation steps have been completed, the machine and its safety features must be tested to ensure correct operation. If you discover a problem with the operation of the machine or its safety components, do not operate it further until you have resolved the problem.

If you discover a problem with the operation of the machine or its safety components, do not operate it further until you have resolved the problem. Refer to the **Troubleshooting** section on **Page 61** for solutions to common problems that may occur with all mills. If you need additional help, contact our Tech Support at (360) 734-1540.

To test run the machine:

1. Read and follow the safety instructions at the beginning of the manual, take required safety precautions, and make sure the machine is set up and adjusted properly
2. Clear away all tools and objects used during assembly and preparation.
3. Make sure that the mill is properly lubricated (refer to the **Lubrication** section on **Page 51** for specific details).
4. Set the spindle speed to the low range (refer to the **Setting Spindle Speed Range** section beginning on **Page 37** for detailed instructions).
5. Move the downfeed selector to the manual (forward) position so that the spindle does not downfeed during this test (refer to the **Downfeed Operations** section on **Page 43** for detailed instructions).
6. Push the emergency STOP button in (see **Figures 13–14**), then twist it clockwise until it pops out. When the switch pops out, the mill is ready for operation.
7. Press the ON button to allow power to flow to the motor, then turn the spindle direction switch to the forward (right) position to start spindle rotation.

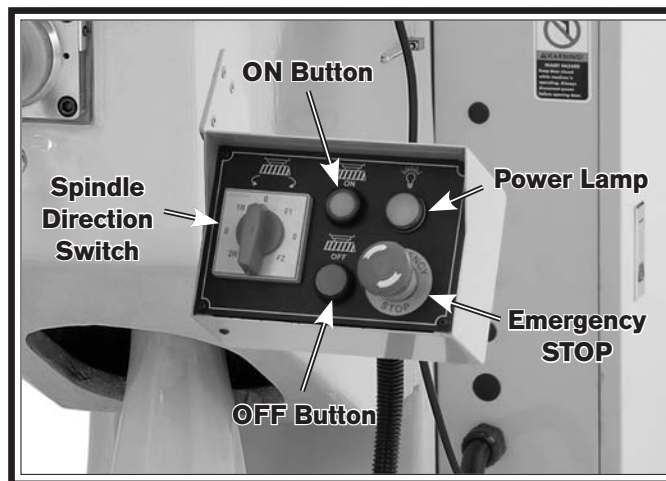

Figure 13. Model SB1025 control panel.

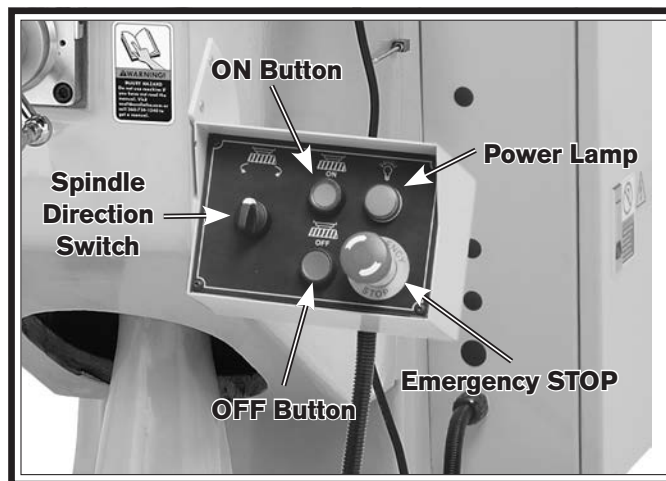

Figure 14. Model SB1024/SB1026 control panel.

Note: For the Model SB1024, turn the spindle direction switch to the **F1** position.

8. Listen for abnormal noises and watch for unexpected actions from the mill. The machine should run smoothly and without excessive vibration or rubbing noises.
 - Strange or unusual noises or actions must be investigated immediately. Press the emergency STOP button to turn the machine **OFF** and disconnect it from the power source before investigating or correcting potential problems.
 9. Press the emergency STOP button to turn the machine **OFF**, then wait for the spindle to stop on its own.
 10. WITHOUT resetting the emergency STOP button, press the ON button. The machine should not start.
 - If the machine does not start, the emergency STOP button safety feature is working correctly.
 - If the machine does start (with the emergency STOP button pushed in), immediately disconnect power to the machine. The emergency STOP button safety feature is not working correctly. This safety feature must work properly before proceeding with regular operations. Call Tech Support for help.
 11. Press the OFF button, then turn the spindle direction switch to the off (middle) position to prevent the spindle from starting when you next use the ON button.
2. Refer to the **Table Movement** section, beginning on **Page 29**, to understand how the power feed, table locks, and limit switch function.
 3. Loosen the table locks on the front of the table.
 4. Plug the power feed power cord into a 110V power outlet.
- Note:** There are 110V outlets on the right side of the electrical cabinet that can be used for the power feed or other 110V accessories.
5. Make sure the power feed directional lever is in the neutral (middle) position, turn the speed dial counterclockwise to the lowest setting, then flip the power switch to the on (up) position.
 6. Turn the directional lever to the left, slowly turn the speed dial clockwise to increase the speed, then confirm that the table is moving to the left.
 7. Watch for the table limit stop to hit the limit switch and turn the power feed **OFF**, stopping the table movement.
 8. Turn the directional lever through the neutral (middle) position and all the way to the right. The table should begin moving to the right.
 9. Confirm that the table stops moving when the limit stop presses against the limit switch plunger.
 10. Move the directional lever to the neutral (middle) position and flip the power switch to the off (down) position.

The mill comes with a power feed unit for X-axis table travel. Proper operation of the limit switch attached to the front middle of the table is critical for the safe use of this power feed unit. If the power feed does not operate as expected during the following steps, disconnect it from power and contact our Tech Support at (360) 734-1540 for assistance.

To test the X-axis power feed unit and table limit switch:

1. Make sure all tools, cables, and other items are well clear of table movement as you follow these steps.

Congratulations! The **Test Run** of the mill is complete. Continue with the next page to perform the **Spindle Break-In and Adjustments & Inspections** procedures.

Spindle Break-In

NOTICE

Complete the spindle bearing break-in procedure to avoid rapid deterioration of spindle components when the mill is placed into operation.

The high-quality bearings and gears used in the mill are manufactured to very close tolerances. However, this does not guarantee perfect dimensional mating of the bearing components or exact meshing of gear teeth. Before operational stress is placed on these and other moving parts in the mill, complete this break-in procedure to conform these components to one another and ensure trouble-free performance from the mill.

To perform the spindle break-in procedure:

1. Successfully perform all the steps in the **Test Run** section beginning on **Page 25**.
2. Make sure the spindle is at a complete stop.
3. Set the spindle speed to the low range (refer to **Setting Spindle Speed Range** beginning on **Page 37** for detailed instructions).
4. Start the spindle rotation at a medium speed and let the mill run for 20 minutes.
5. Stop the spindle rotation and allow the spindle to come to a complete stop by itself.
6. Set the spindle speed to the high range, then start the spindle rotation at a medium speed and let the mill run for another 20 minutes.
7. Stop the spindle rotation, and turn the mill **OFF**.

The spindle break-in of the mill is now complete!

NOTICE

Since the mill head was rotated parallel to the table for shipping purposes, you will need to tram the spindle with the table if your first cut requires a 90° alignment. Refer to the **Tramming Spindle** section on **Page 33** for detailed instructions.

Inspections & Adjustments

The following list of adjustments were performed at the factory before the machine was shipped:

- Gib AdjustmentPage 58
- Leadscrew Backlash Adjustment.....Page 59

Be aware that machine components can shift during the shipping process. Pay careful attention to these adjustments during operation of the machine. If you find that the adjustments are not set according to the procedures in this manual or your personal preferences, re-adjust them.

Operation Overview

The purpose of this overview is to give an example of a typical milling operation. Read through the steps below to better understand the controls and functions described later in this manual, so that you will know how they are used to successfully operate the mill.

This overview is not intended to be a step-by-step operational guide.

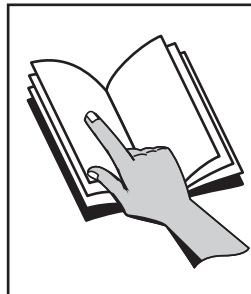

!WARNING

To reduce the risk of serious injury when using this machine, read and understand this entire manual before beginning any operations.

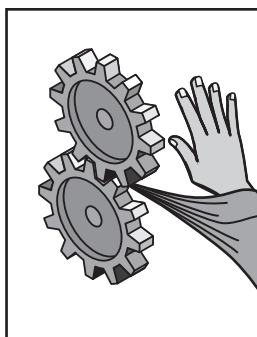

!WARNING

Loose hair, clothing, or jewelry could get caught in machinery and cause serious personal injury. Keep these items away from moving parts at all times to reduce this risk.



!WARNING

During operation, small metal chips may become airborne, leading to serious eye injury. Wear safety glasses to reduce this risk.

In a typical milling operation, the operator does the following:

1. Examines the workpiece to make sure it is suitable for milling.
2. Firmly clamps the workpiece to the table.
3. Installs the correct cutting tool for the operation.
4. Uses the manual downfeed and table controls to confirm the correct positioning of the cutting tool and workpiece for the operation. If the X-axis power feed will be used during the operation, the operator confirms the speed and length of table movement required.
5. Configures the mill for the correct spindle speed of the operation.
6. Puts on personal protective gear and makes sure the workpiece and table are clear of all tools, cords, and other items.
7. Starts the spindle rotation and performs the operation.
8. Turns the mill **OFF**.

Control Panel

Use **Figures 15–16** and the following descriptions to understand the functions of the mill control panel.

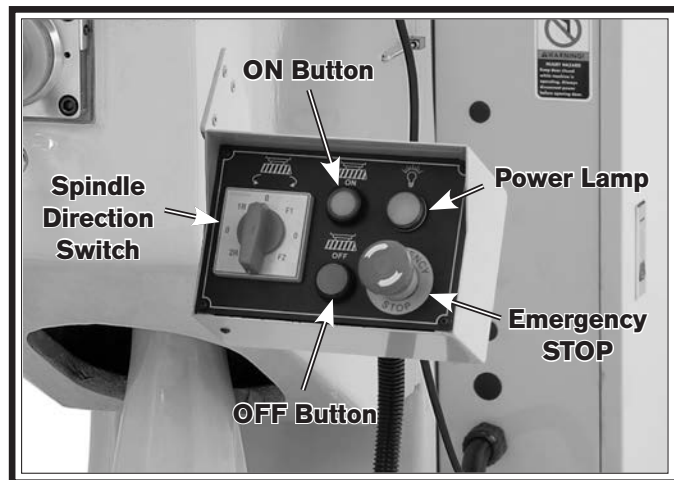

Figure 15. Model SB1025 control panel.

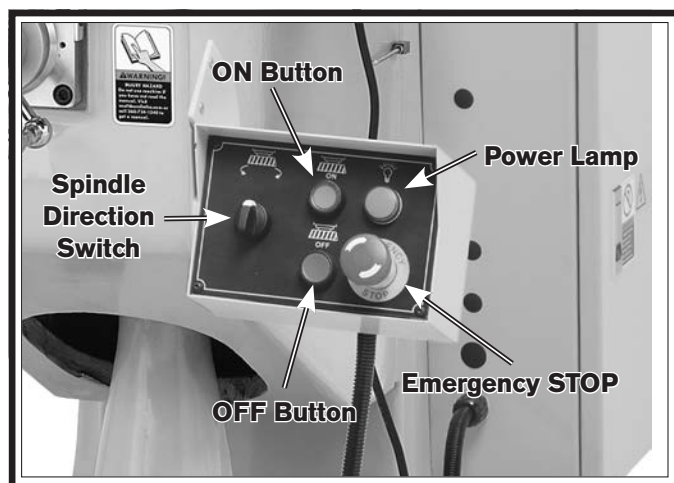

Figure 16. Model SB1024/SB1026 control panel.

Spindle Direction Switch: Starts, stops, and reverses the direction of spindle rotation.

Note: The Model SB1025 has two positions for each direction that electronically change the speed of the motor and work in conjunction with the belt housing controls to set the spindle speed range (refer to "To set the spindle speed range for the Model SB1025" on **Page 39** for additional details).

ON Button: Allows power flow to the motor. The spindle direction switch must be used to start the spindle rotation.

Power Lamp: Illuminates when the mill is connected to a power source.

Emergency STOP Button: Stops the flow of power to the motor. Twist clockwise until it pops out to reset it, then press the ON button to re-establish power flow to the motor.

OFF Button: Stops power flow to the motor.

Table Movement

The mill table moves in three directions, as illustrated in **Figure 17**:

- X-axis (longitudinal)
- Y-axis (cross)
- Z-axis (vertical)

These movements are controlled by table ball handles and the Z-axis crank. Additionally, the table can be moved along the X-axis with the power feed.

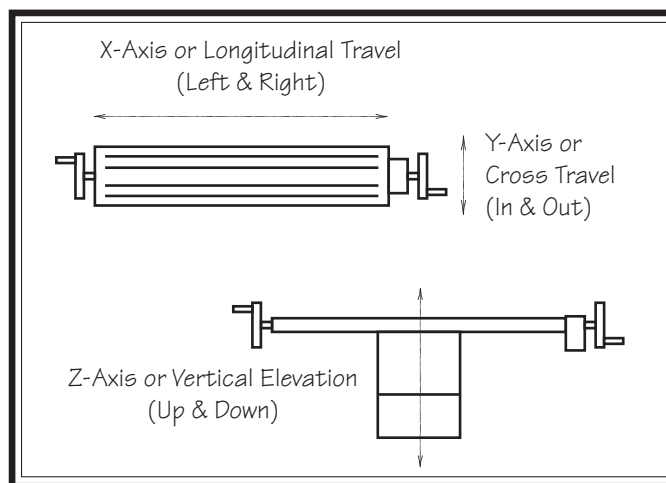

Figure 17. The directions of table movement.

Graduated Index Rings

The table ball handles and elevation crank have graduated index rings attached (see **Figure 18**) that are used to accurately determine table movement in increments, as listed in the table below:

Axis	Individual Increment	One Full Revolution
X	0.001"	0.200"
Y	0.001"	0.200"
Z	0.001"	0.100"

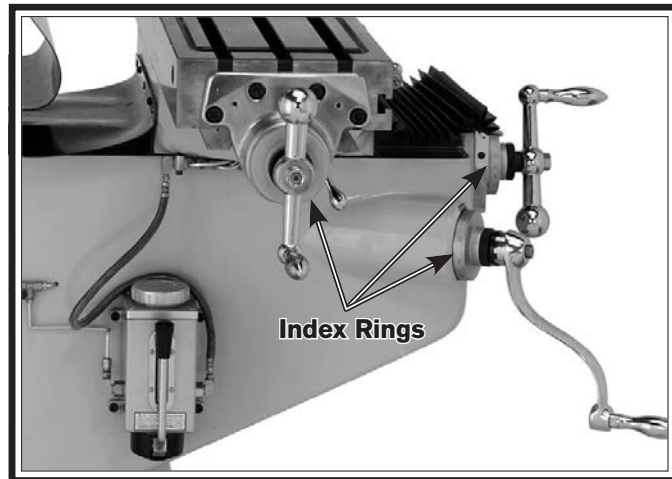

Figure 18. Graduated table index rings.

⚠ CAUTION

Always keep the table locked in place unless table movement is required for your operation. Unexpected table and workpiece movement could cause the cutter to bind with the workpiece, which could result in personal injury or damage to the cutter and workpiece.

Table Locks

Refer to **Figure 19** for the locations of the locks used to secure the table in place.

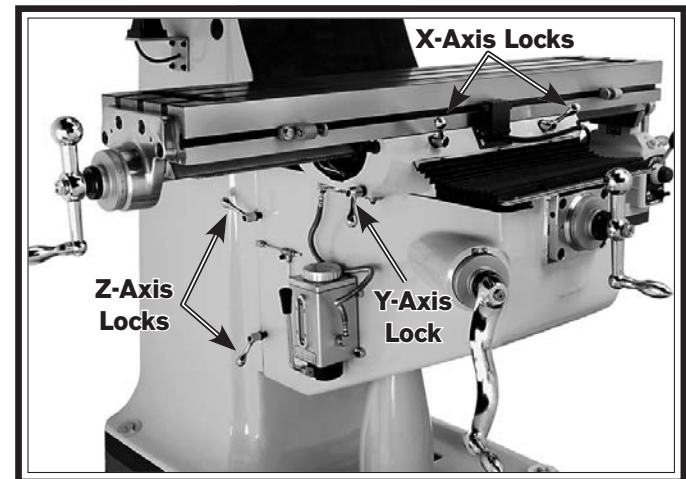

Figure 19. Locations of table locks.

X-Axis Power Feed

The mill is equipped with a power feed unit for X-axis table movement. Refer to the illustration in **Figure 20** and the descriptions below to understand the functions of the various components of the power feed system.

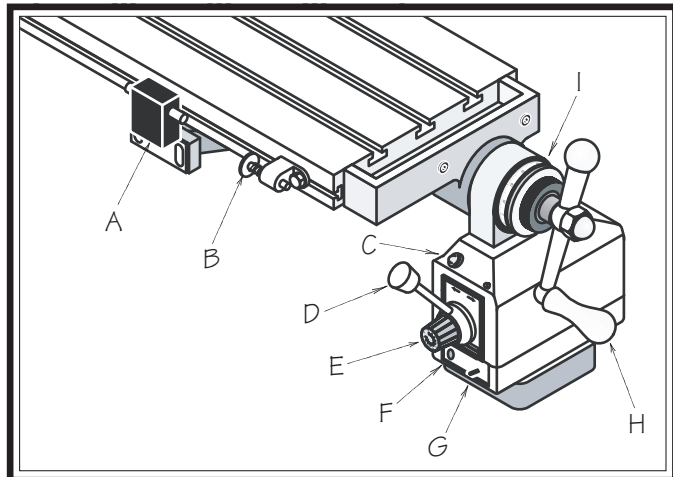

Figure 20. Power feed system components.

- A. Limit Switch:** Stops table movement when either of the switch side plungers are pressed by the limit stops.
- B. Limit Stop:** Restricts table movement when positioned along the front of the table.
- C. Rapid Traverse Button:** Moves the table at full speed when it is in motion.
- D. Directional Lever:** Selects the direction of table movement. The middle position is neutral.
- E. Speed Dial:** Controls the speed of the power feed. Turning the dial clockwise causes the table to move faster.
- F. Circuit Breaker Reset Button:** Resets the internal circuit breaker if the unit is overloaded and shuts down.
- G. Power Switch:** Turns the power feed **ON** and **OFF**.

H. X-Axis Ball Handle: Manually moves the table.

I. Graduated Index Ring: Display the distance of table travel in 0.001" increments, with one full revolution equal to 0.200" of table travel.

To confirm the power feed settings that you will be using during operation, we recommend that you use the power feed to move the table through the intended cutting path before starting the spindle rotation and taking the cut

Tool Needed	Qty
Hex Wrench 12mm	1

To operate the X-axis power feed:

1. Loosen the X-axis table locks (refer to **Figure 19** on **Page 30** for locations).
 2. Position the limit stops along the front table slot to limit the distance of table travel that is correct for your operation.
- Note:** Make sure the cap screws firmly lock the limit stops in place when positioned.
3. Turn the speed dial all the way counterclockwise to slowest setting, move the directional lever to neutral (middle) position, then flip the power switch up to turn the unit **ON**.
 4. With your hand poised over the power switch in case you need to suddenly turn the unit **OFF**, move the directional lever in the desired direction of table travel.
 5. Use the speed dial to slowly bring the speed of movement up to the desired rate.
 6. When you are finished using the power feed, turn the unit **OFF**, then rotate the speed dial all the way clockwise and move the directional lever to the neutral (middle) position to avoid unexpected table movement when you next flip the power switch up.

Head Movement

The head tilts 45° back and forth, and rotates 90° left and right, as shown in **Figures 21–22**.

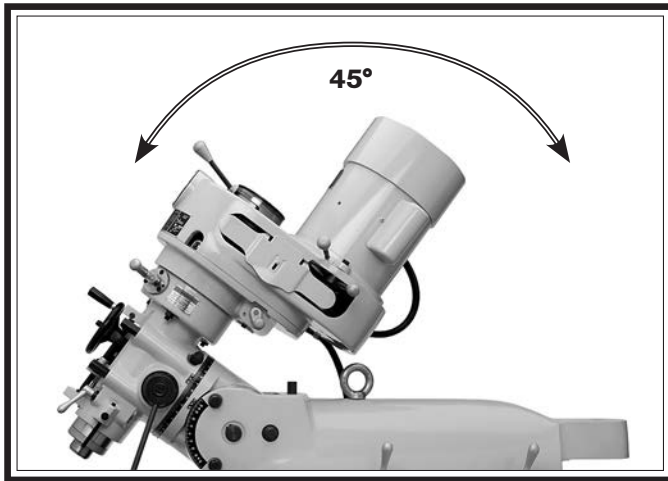

Figure 21. Head tilts 45° back-and-forth.

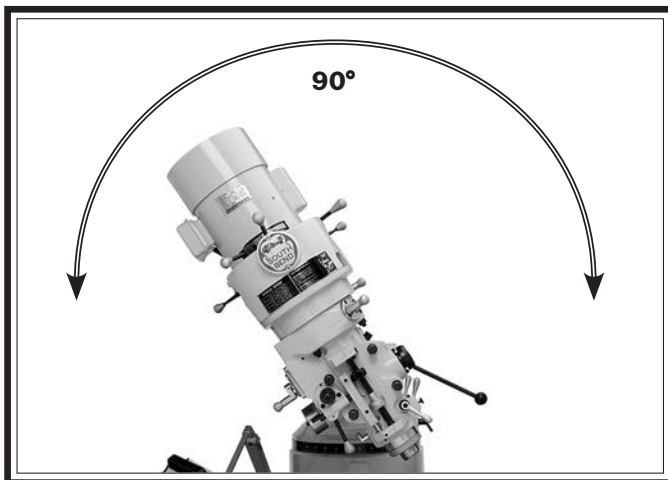

Figure 22. Head tilts 90° left-and-right.

NOTICE

Always lock the head firmly in place after tilting or rotating it. Unexpected movement of the head during operations could cause damage to the cutter or workpiece.

Tool Needed

	Qty
Wrench 19mm	1

Tilting Head

1. DISCONNECT MILL FROM POWER!
2. Loosen the three tilt lock bolts on the right side of the ram adapter shown in **Figure 23**.

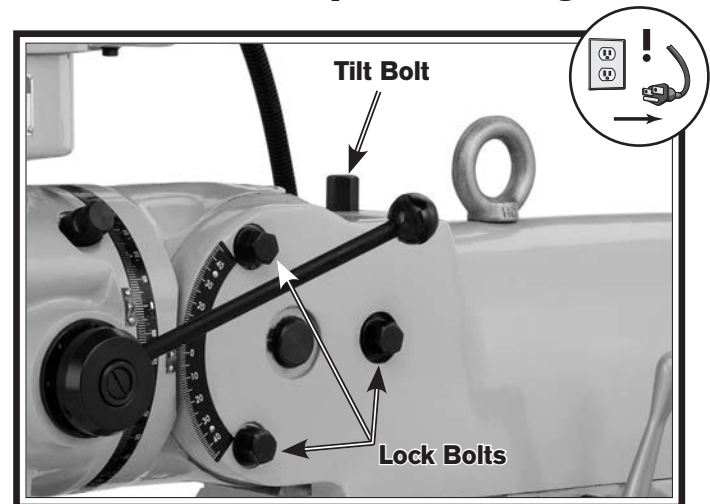

Figure 23. Head tilting controls.

3. Use one hand to apply pressure to the head in the direction of rotation, then slowly rotate the tilt bolt. Rotating this bolt clockwise will tilt the head back.
4. When the head is in the correct position for your operation, re-tighten all three lock bolts.

Rotating Head

1. DISCONNECT MILL FROM POWER!
2. Loosen the four rotation lock bolts on the face of the head shown in **Figure 24**.

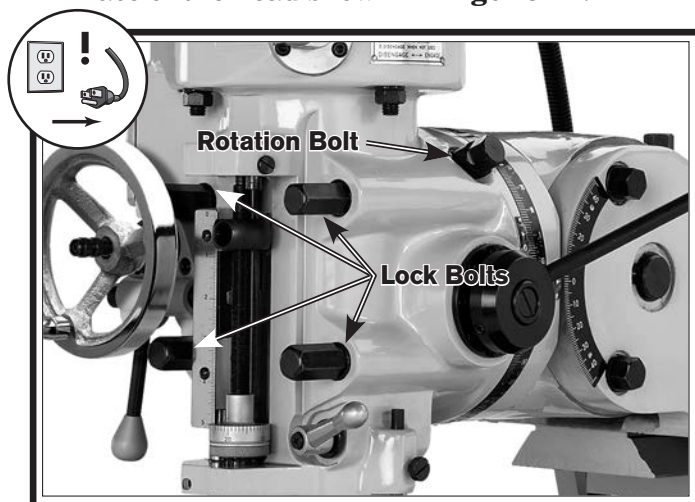

Figure 24. Head rotating controls.

3. Use one hand to apply pressure to the head in the direction of tilt, then slowly turn the rotation bolt.
4. Re-tighten the lock bolts when you have the head in the desired position.

Tramming Spindle

After positioning the head at an angle and when your operation requires that the spindle axis be precisely perpendicular to the table, you must tram or align the spindle with the table to ensure the spindle is exactly 90° to the table.

This procedure involves mounting a dial test indicator to the quill or spindle, rotating it around the table, and adjusting the spindle axis (Z-axis) 90° to the table X- and Y-axes, as illustrated in **Figure 25**.

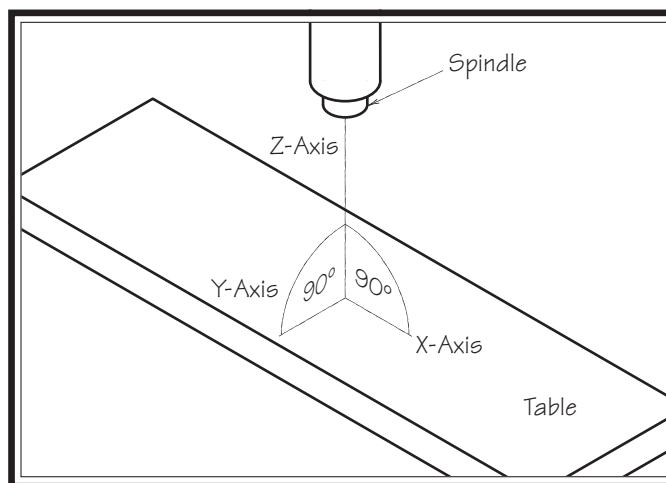

Figure 25. Spindle axis perpendicular to the table X- and Y-axes.

We encourage you to research the many variations of spindle tramming to find the one that works best for you. If you do not already have a preference for performing this operation, use the following widely-used procedure for accurately tramming the spindle to the table.

Keep in mind that all workpiece top surfaces are not exactly parallel with the table top. You may choose to tram the spindle to the top surface of the workpiece after it is mounted instead of that of the table.

Tools Needed

	Qty
Dial Test Indicator (with at least 0.0005" resolution)	1
Indicator Holder (mounted on the quill/spindle)	1
Precision Parallel Block (at least 9" in length)	1

Note: A precision-ground plate can be substituted for the parallel blocks. Keep in mind that the farther the indicator point can be placed from the spindle axis, the more accurate the alignment measurements will be.

To tram the spindle to the table:

1. DISCONNECT MILL FROM POWER!
2. Prepare the mill by performing the following tasks:
 - Stone the table to remove all nicks and burrs, then clean off all debris. Verify the table is clean by running your hand over the top of it.
 - Position the table for the milling operation you intend to perform after the tramping—preferably centered to the saddle.
 - Tighten any table, knee, quill, or ram locks that should be tight during the intended milling operation.
3. Place the parallel block underneath the spindle.

4. Install the indicator holder into the spindle or onto the quill, then mount the indicator onto it so that the point is as parallel to the block as possible (see the illustration in **Figure 26** for an example).

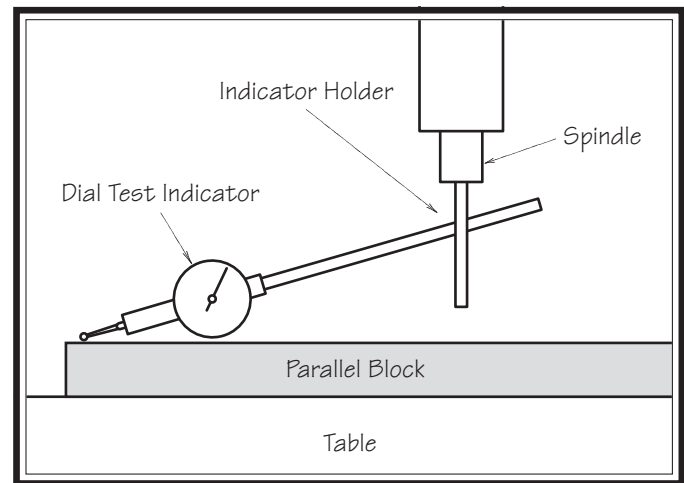

Figure 26. Dial test indicator mounted.

5. To measure spindle alignment along the X-axis, place the parallel block directly under the spindle and indicator across the length of the table, as illustrated in **Figure 27**.

Note: If you must re-position the quill or the knee to accommodate the above step, then review the tasks in **Step 2** to make sure the mill is properly prepared for the tramping operation.

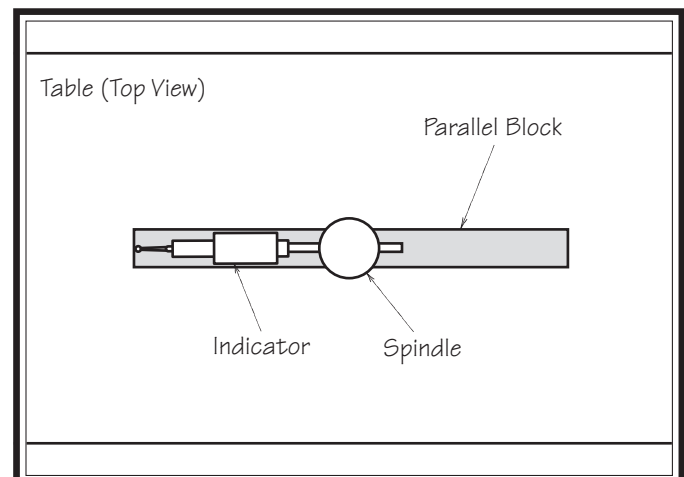

Figure 27. Parallel block positioned for the X-axis measurement (top view).

Note: Generally, the goal in the next steps is to get the difference of the indicator readings between the end of the parallel bar down to 0.0005". However, the acceptable variance will depend on the requirements for your operation.

6. Rotate the spindle by hand so that the indicator point rests on one end of the parallel block, as illustrated in **Figure 27**, then zero the dial.
7. Rotate the spindle so that the indicator point rests in the same manner on other end of the block, then read the dial.

— If the indicator dial still reads zero or is within the acceptable variance, continue on with **Step 8**.

— If the indicator dial has moved from zero beyond the acceptable variance, you will need to compensate for that amount by rotating the head left or right. Repeat **Steps 5–6** until you are satisfied with the spindle axis alignment along the table X-axis.

Note: Keep one of the rotation lock bolts just snug so that the head does not move loosely while you adjust it small amounts. Remember to tighten the rotation lock bolts after adjusting the head.

8. Place the parallel block directly under the spindle and across the width of the table, as illustrated in **Figure 28**.

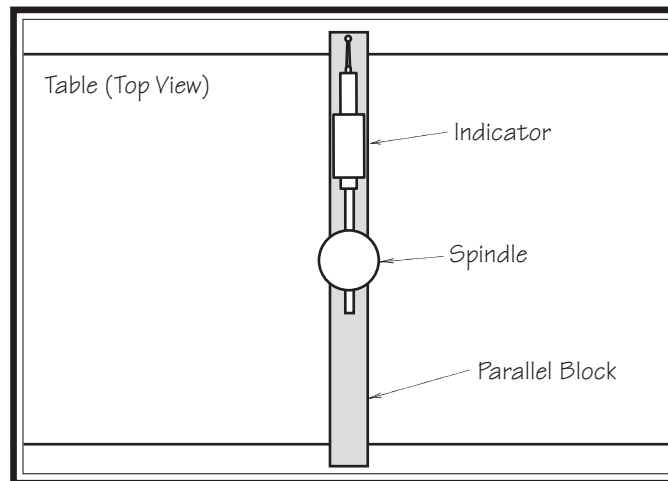

Figure 28. Parallel block positioned for the Y-axis measurement (top view).

9. Rotate the spindle so that the indicator point rests on the parallel bar, as illustrated in **Figure 28**, then zero the dial.
10. Rotate the spindle so that the indicator point rests on the other end of the bar in the same manner, then read the dial.

— If the indicator dial still reads zero or is within the acceptable variance, the spindle is precisely perpendicular to the table in both the X- and Y-axes and the tramping procedure is complete.

— If the indicator dial has moved from zero beyond the acceptable variance, you will need to compensate for that amount by tilting the head forward or back. Repeat **Steps 9–10** until you are satisfied with the spindle axis alignment along the table Y-axis.

Note: Keep one of the tilt lock bolts just snug so that the head does not move loosely while you adjust it small amounts. Remember to tighten the tilt lock bolts after adjusting the head.

Ram Movement

The ram travels back and forth 13" and rotates 360° in either direction around the turret.

Tool Needed

Wrench 19mm 1

Qty

Moving Ram Back-and-Forth

1. DISCONNECT MILL FROM POWER!
2. Loosen the two lock levers shown in **Figure 29** on the right side of the ram.

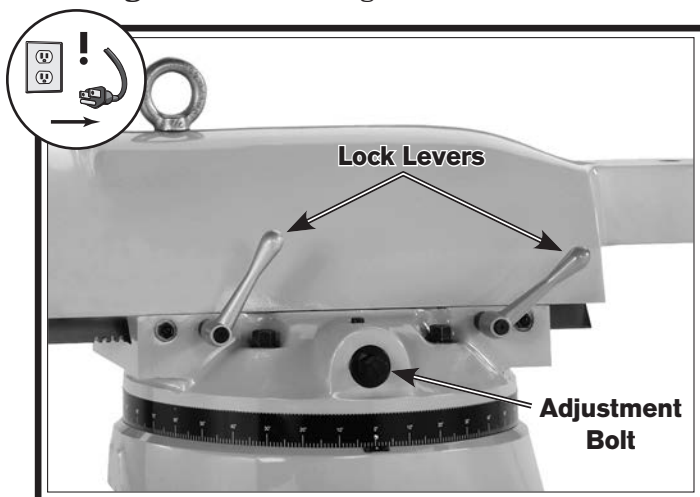

Figure 29. Ram back-and-forth movement controls.

3. Make sure there are no obstructions to ram travel, especially with the spindle tool around the workpiece, then slowly rotate the adjustment bolt to move the ram. Rotating the bolt clockwise will move the ram back.
4. Re-tighten the lock levers after you have re-positioned the ram.

NOTICE

Always lock the head firmly in place after tilting or rotating it. Unexpected movement of the head during operations could cause damage to the cutter or workpiece.

Rotating Ram

1. DISCONNECT MILL FROM POWER!
2. Loosen the four lock bolts on top of the turret (see **Figure 30**).

Note: There are two lock bolts on either side of the ram.

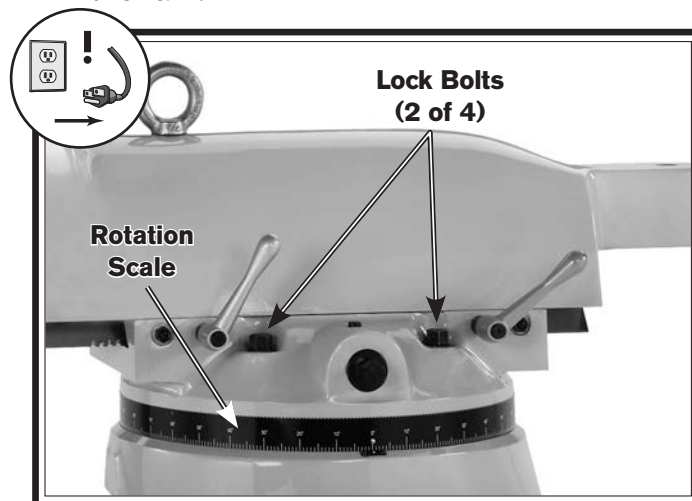

Figure 30. Ram rotating controls.

Note: In the next step, take care not to entangle or stretch the electrical cabling as you move the ram around the turret.

3. Push on the head to manually rotate it. Use the rotation scale to determine the correct position for your operation, then re-tighten the four lock bolts to secure the ram in place.

Setting Spindle Speed

Using the correct spindle speed is important for safe and satisfactory results, as well as maximizing tool life.

To set the spindle speed for your operation, you will need to: (1) Determine the best spindle speed for the cutting task, and (2) configure the mill controls to produce the required spindle speed.

Determining Spindle Speed

Many variables affect the optimum spindle speed to use for any given operation, but the two most important are the recommended cutting speed for the workpiece material and the diameter of the cutting tool, as noted in **Figure 31**:

<p>*Recommended Cutting Speed (FPM) x 12</p> <hr/> <p>Tool Dia. (in inches) x 3.14</p> <p>= Spindle Speed (RPM)</p> <p><small>*Double if using carbide cutting tool</small></p>
--

Figure 31. Spindle speed formula for milling.

Cutting speed, typically defined in feet per minute (FPM), is the speed at which the edge of a tool moves across the material surface.

A recommended cutting speed is an ideal speed for cutting a type of material in order to produce the desired finish and optimize tool life.

The books **Machinery's Handbook** or **Machine Shop Practice**, and some internet sites, provide excellent recommendations for which cutting speeds to use when calculating the spindle speed. These sources also provide a wealth of additional information about the variables that affect cutting speed and they are a good educational resource.

Also, there are a large number of easy-to-use spindle speed calculators that can be found on the internet. These sources will help you take into account all applicable variables to determine the best spindle speed for the operation.

Setting Spindle Speed Range

Setting the spindle speed range involves engaging and disengaging a spindle spline that uses gearing to increase or decrease the range of spindle speeds.

The procedures to set the speed range for the Model SB1024 and Model SB1025/SB1026 differ slightly. Use the appropriate section on the following pages for the mill when selecting the speed range.

NOTICE

To avoid damage to the spindle, gears, or cutting tools:

- **Spindle rotation must be turned OFF and the spindle must be at a complete stop BEFORE you change the spindle speed range.**
- **The mill is designed to ONLY operate with the spindle speed range selector in either the high or low position. To avoid damaging the moving parts inside the headstock, never start spindle rotation without the range selector detent pin firmly seated in either the high or low position.**
- **When changing the spindle speed range and the direction of spindle rotation reverses, you will need to either change the cutting tool to match the direction of spindle rotation or use the spindle direction switch to compensate for the reversal.**

Note: Regardless of the model of the mill, you **MUST** properly perform the **Meshing Spindle & Spindle Clutch** procedure as instructed on **Page 40** when using the high spindle speed range.

⚠ CAUTION

When the spindle speed range is changed, the direction of spindle rotation will reverse. **ALWAYS** know which way the spindle is rotating before beginning the cutting operation.

Setting SB1024 Spindle Speed Range

1. Make sure that the spindle rotation is turned **OFF** and the spindle is at a complete stop.
2. Use the chart below to find the spindle speed range that includes the required spindle speed for your operation.

Model SB1024 Spindle Speed Ranges

Low Range	60–500 RPM
High Range	500–4200 RPM

3. Press the spindle speed range lever shown in **Figure 32** toward the head to release the detent pin from the detent plate, move selector so that the pin is over the other detent, then release the selector.
 - When the selector is pointing to the rear and the front detent is engaged, the low speed range is selected. Conversely, when the lever is pointing toward the front and the rear detent is engaged, the high speed range is selected.

Note: If it is difficult to move the range selector, rotate the spindle by hand to help mesh the gears until the selector moves freely.

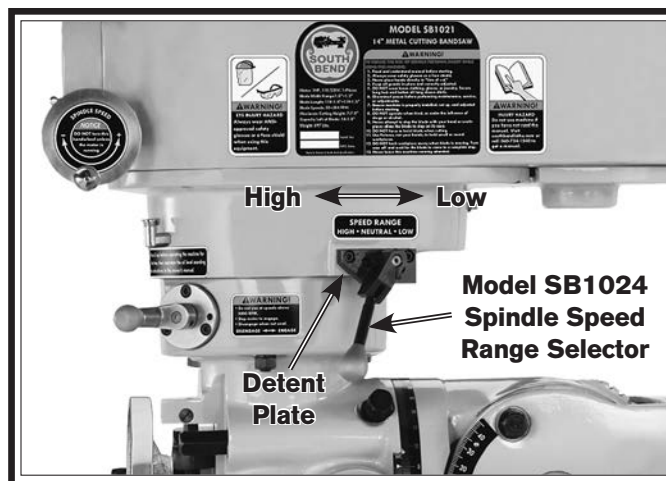

Figure 32. Model SB1024 spindle speed range selector.

4. Make sure the selector detent pin is well seated by attempting to move the selector without pressing it toward the head.
 - If the detent pin is well seated, the selector will not move when you attempt to move it as instructed above.
 - If the selector does move when you attempt to move it as instructed above, then re-position the selector so that the pin is firmly seated in the detent plate.
5. Perform the **Meshing Spindle & Spindle Clutch** procedure as instructed on **Page 40** to make sure the front spindle pulley and pinion are properly seated into the bull gear.

NOTICE

Properly setting the spindle speed range for the Model SB1025/SB1026 involves correctly positioning the high/low range lever AND the spindle speed range selector. ALWAYS make sure these two devices are properly set before beginning the spindle rotation to avoid damaging the machine and voiding the warranty.

Setting SB1025/SB1026 Spindle Speed Range

1. Make sure that the spindle rotation is turned **OFF** and the spindle is at a complete stop.
2. Use the charts below to find the spindle speed range that includes the required spindle speed for your operation.

Note: The Model SB1025 spindle direction switch on the control panel has four settings that change the direction and speed of the spindle motor for each spindle speed range. Positions **F1** (forward) and **R1** (reverse) use the low motor speed, and **F2** and **R2** use the high motor speed. Use **Figure 15** on **Page 29** as a visual reference for the spindle direction switch positions.

Model SB1025 Spindle Speed Ranges

Low Range w/Switch @ F1/R1	80–325 RPM
Low Range w/Switch @ F2/R2	160–650 RPM
High Range w/Switch @ F1/R1	710–2800 RPM
High Range w/Switch @ F2/R2	1420–5600 RPM

Model SB1026 Spindle Speed Ranges

Low Range	80–325 RPM
High Range	710–2800 RPM

3. **Low Spindle Speed Range:** Pull the knob of the spindle speed range selector (see **Figure 33**) out to disengage the detent pin, rotate the selector clockwise to the front position, then release the knob.

Note: If it is difficult to move the range selector, rotate the spindle by hand to help mesh the gears until the selector moves freely.

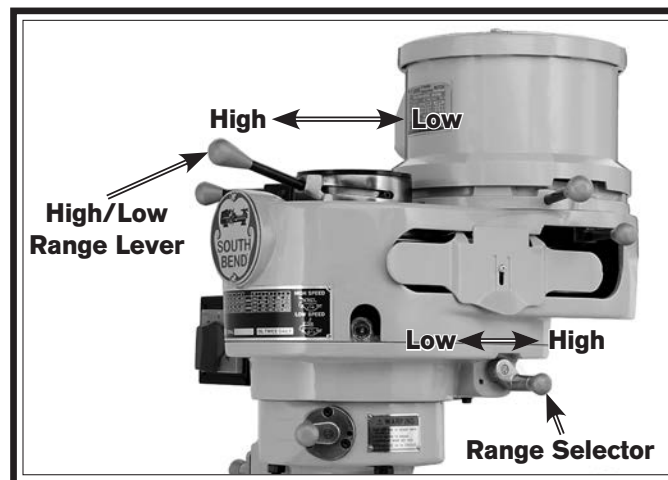
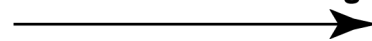

Figure 33. Model SB1025/SB1026 spindle speed range controls.

4. Make sure the selector detent pin is well seated by attempting to move the selector without pressing it toward the head.
 - If the detent pin is well seated, the selector will not move when you attempt to move it, as instructed above.
 - If the selector does move when you attempt to move it, as instructed above, then re-position the selector so that the pin is firmly seated.

Continued On Next Page



5. Move the high/low range lever back to the right side of the head (see **Figure 33**).

Note: Make sure that the range lever is as far back as it will go before starting the spindle rotation.

Tip: When the spindle speed range selector and high/low range lever are correctly set, they will be in the opposite direction from each other.

6. **High Spindle Speed Range:** Move the high/low range lever forward so that it is pointing to the front of the head.

Note: Make sure that the range lever is as far forward as it will go before starting the spindle rotation.

7. Pull the knob of the spindle speed range selector out to disengage the detent pin, rotate the selector clockwise to the rear position, then release the knob.

Note: Make sure the selector detent pin is well seated before starting the spindle rotation.

8. Perform the **Meshing Spindle & Spindle Clutch** procedure as instructed on **Page** to make sure the front spindle pulley and pinion are properly seated into the bull gear.

When setting the mill to use the high spindle speed range, the front spindle pulley must mesh with the spindle clutch. Otherwise, you will hear an unusual grinding when spindle rotation is started and damage to these components could be the result.

Meshing Spindle & Spindle Clutch

1. DISCONNECT MILL FROM POWER!
2. Set the spindle speed range control(s) for the mill as instructed on the previous pages.

— If you hear/feel the front pulley drop into the spindle clutch when you set the control(s), this procedure is complete and you can continued with spindle speed setup.

— If you do not hear/feel the front pulley drop into the spindle clutch when you set the control(s), continue with **Step 3**.

Note: The following step takes experience and patience to complete properly.

3. Firmly grasp the spindle, then quickly rotate it in a back-and-forth motion until you hear/feel the front pulley drop into the spindle clutch.

— If **Step 3** was not successful, use the spindle speed range control(s) to re-set the mill to the low range, then repeat **Step 3** until you are certain that the front pulley is seated into the spindle clutch.

Setting Spindle Speed

The Model SB1024 uses a variable pulley system to set infinite speeds within the speed range selected. The Model SB1025/SB1026 requires re-positioning the V-belt on the pulleys to change spindle speed.

Use the appropriate section below for the mill to select the correct spindle speed.

NOTICE

For the Model SB1024 ONLY, always make sure that the spindle rotation has been started and is at a constant speed before using the variable speed handwheel to adjust the spindle speed. Otherwise, the moving parts inside the belt housing could be damaged and void the warranty.

Setting SB1024 Spindle Speed

1. Start the spindle rotation.
2. Slowly rotate the speed handwheel shown in **Figure 34** until the desired speed is displayed in the speed indicator window for the speed range selected.

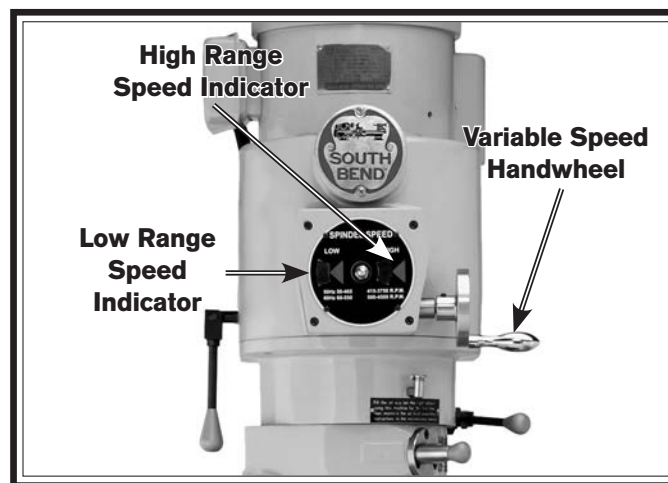

Figure 34. Model SB1024 variable spindle speed handwheel and indicator windows.

Setting SB1025/SB1026 Spindle Speed

1. DISCONNECT MILL FROM POWER!
2. Remove the belt housing side covers on both sides of the head to expose the V-belt and pulleys, as shown in **Figure 35**.

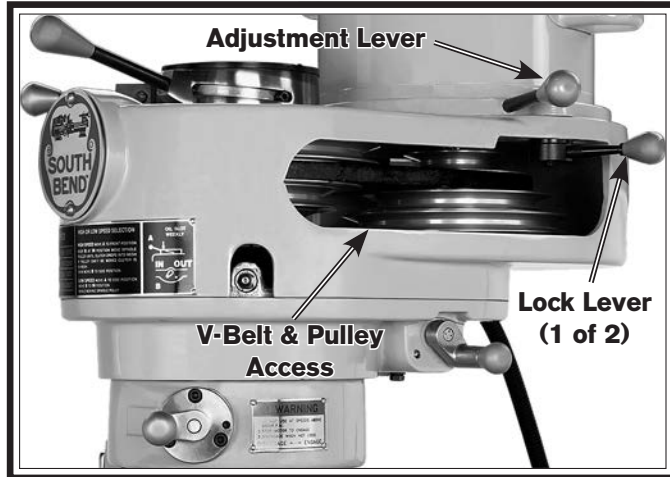

Figure 35. V-belt and pulleys exposed (Model SB1026 shown).

3. Loosen the two motor lock levers, one on either side of the head, then pull the belt tension adjustment lever forward to release the V-belt tension.
4. Refer to the illustrations in **Figures 36–37** and position the V-belt on the pulleys for the desired spindle speed.

Note: The Models SB1025 and SB1026 produce slightly different spindle speeds for each V-belt position. Make sure you refer to the correct illustration for the mill.

Also, Model SB1025 has two spindle speeds for each V-belt position that are selected by using the spindle direction switch on the control panel. **F1/R1** will produce the lower of the two speeds for each spindle speed range and V-belt position.

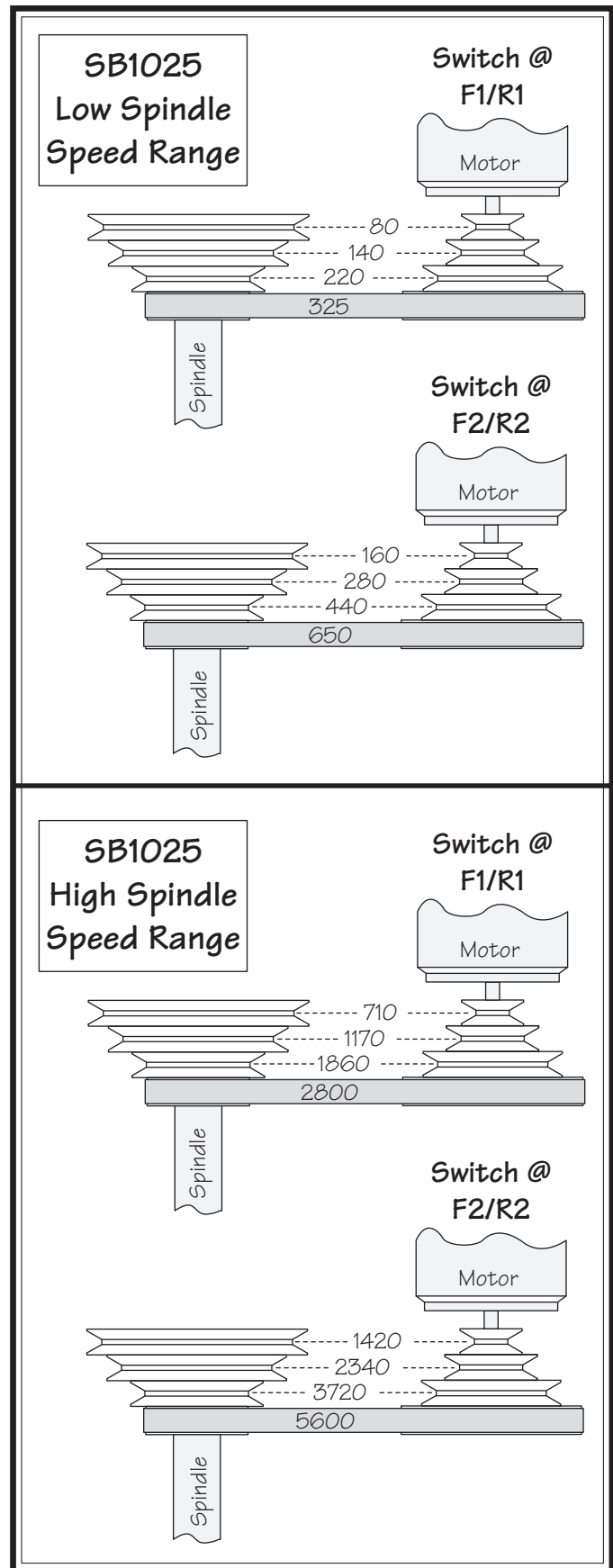

Figure 36. Model SB1025 V-belt positions and speeds.

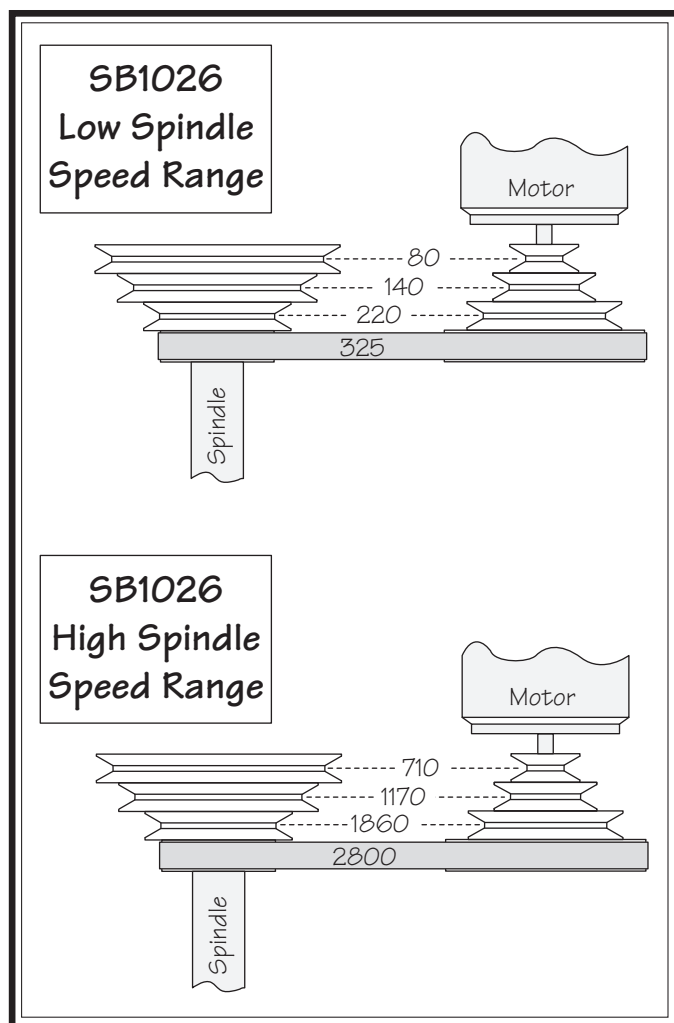

Figure 37. Model SB1026 V-belt positions and speeds.

5. To re-tension the V-belt, push the adjustment lever back with moderate force, then re-tighten the two lock levers to secure the motor in place.
6. Replace the two belt housing side covers before re-connecting the mill to power.

⚠ CAUTION

To avoid entanglement hazards, always make sure that the two belt housing safety covers are firmly in place before connecting the mill to power.

Downfeed Controls

Spindle downfeed movement on the mill is controlled by three mechanisms: 1) The coarse downfeed handle, 2) the fine downfeed handwheel, and 3) the auto-downfeed system.

Using the Coarse Downfeed Handle

1. Make sure that the spindle rotation is turned **OFF** and the spindle is at a complete stop.
2. To set the downfeed for manual control, pull the downfeed selector knob out, then rotate it clockwise until the selector pin under the knob seats in the forward manual (disengaged) position, as shown in **Figure 38** and illustrated in **Figure 39** on the next page.

Note: It may be necessary to turn the spindle by hand as you move the selector to enable the gears to mesh.



Figure 38. Downfeed selector in the manual (disengaged) position.

3. Make sure the selector pin is firmly seated in the detent by attempting to move the selector without pulling the knob out.

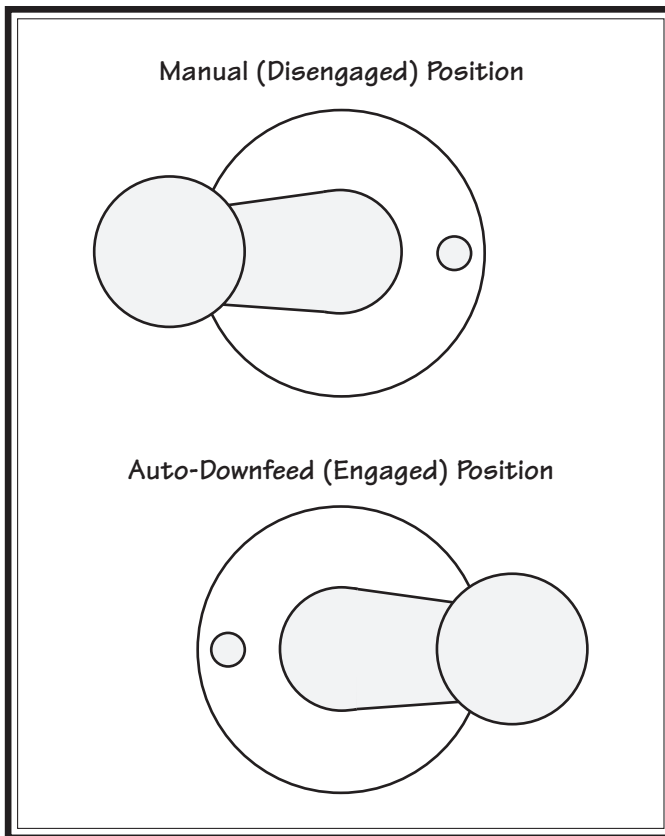

Figure 39. Downfeed selector positions.

4. Make sure the pin of the coarse downfeed handle hub is engaged with one of the detents on the downfeed sleeve (see **Figure 40**).

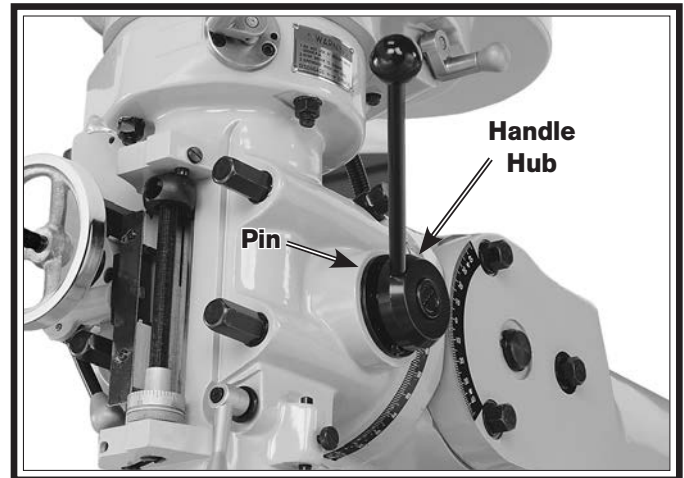

Figure 40. Coarse downfeed handle hub and detent pin.

5. Make sure the quill lock lever is loose so that the quill can easily move.
6. Rotate the coarse downfeed handle around the hub to control the depth of the spindle.

Fine Downfeed Controls

There are a number of devices on the head that are used with the fine downfeed handwheel or the auto-downfeed system. Refer to **Figure 41** and the descriptions below to become familiar with these controls.

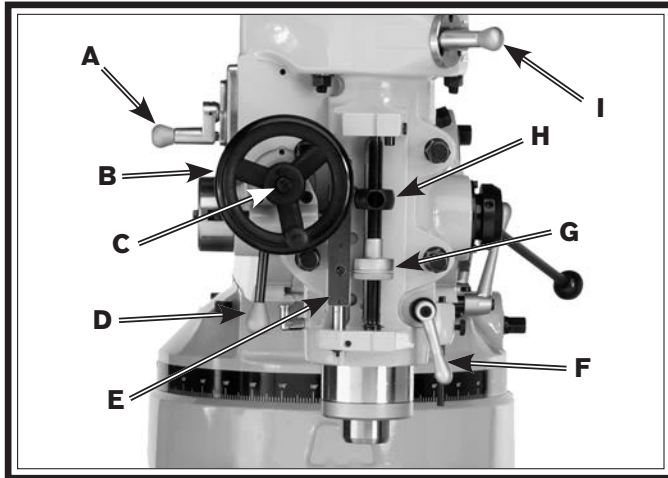

Figure 41. Fine downfeed controls.

A. Auto-Downfeed Rate Selector: Selects one of the three auto-downfeed rates.

B. Fine Downfeed Handwheel: Manually controls fine spindle downfeed.

NOTICE

When the spindle rotation is reversed, either by changing the spindle speed range or by using the spindle direction switch, the direction of spindle auto-downfeed will reverse.

C. Auto-Downfeed Direction Pin: Starts, stops, and reverses the auto-downfeed direction.

D. Fine Downfeed Clutch Lever: Engages the fine/auto-downfeed gears.

E. Downfeed Scale: Used with the quill dog, shows the depth of spindle downfeed in inches.

F. Quill Lock Lever: Secures the quill in place for increased stability during operations.

G. Downfeed Stop & Locking Wheel: Sets the depth of spindle downfeed. The stop is threaded into position, then the locking wheel is used to secure it in place.

H. Quill Dog: Moves with the quill and spindle and disengages the downfeed clutch lever when it engages either the top or the downfeed stop.

I. Downfeed Selector: Sets the mill for manual downfeed or auto-downfeed control.

Using the Fine Downfeed Handwheel

1. Make sure that the spindle rotation is turned **OFF** and the spindle is at a complete stop.
2. To set the downfeed for manual control, pull the downfeed selector knob out, then rotate the selector clockwise until the selector pin seats in the forward manual (disengaged) position.
3. Set the auto-downfeed direction pin in the neutral (middle) position to disengage the fine downfeed handwheel from the auto-downfeed gears.
4. Position the downfeed stop for the spindle depth that is correct for your operation, then secure it in place with the locking wheel.
5. Use the coarse downfeed lever to lower the spindle slightly until you can pull the clutch lever out to the left and it locks in place. This will engage the handwheel with the quill and spindle.
6. To lower the spindle, rotate the fine downfeed handwheel. When the quill dog meets the downfeed stop, the clutch lever will disengage and the spindle will return to the top.

Using the Auto-Downfeed System

When using the auto-downfeed system, the spindle will move in the direction you choose with the auto-downfeed direction pin. When the quill dog reaches the top or meets the downfeed stop, the downfeed clutch lever will release. Then, if the spindle was traveling upward, the movement will simply stop. If the spindle was traveling downward, then the spindle will move back to the top at a rate controlled by the return spring on the left side of the head.

To use the auto-downfeed system:

1. Make sure that the spindle rotation is turned **OFF** and the spindle is at a complete stop.
2. To set the mill for auto-downfeed, pull the downfeed selector knob out, then rotate the selector clockwise and seat the pin in the rear auto-downfeed (engaged) position, as illustrated in **Figure 42**.

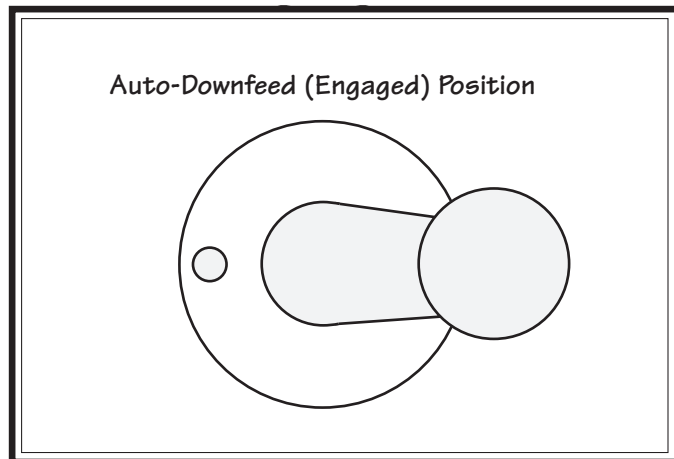

Figure 42. Downfeed selector in the auto-downfeed (engaged) position.

3. Position the downfeed stop for the spindle depth that is correct for your operation, then secure it in place with the locking wheel.

4. Position the auto-downfeed direction pin for the spindle travel that is correct for your operation. It may be necessary to rock the fine downfeed handwheel back-and-forth to move the pin all the way in or out.

Note: The direction pin has three positions: 1) **In** for one downfeed direction, 2) **middle** for neutral or no movement, and 3) **out** for the reverse direction. The direction of spindle travel for the in and out positions is relative to the direction of spindle rotation. Keep in mind that spindle rotation and downfeed direction will reverse when the spindle speed range is changed.

5. Make sure the clutch lever is all the way to the right in the disengaged position so that the spindle will not travel when rotation is started.

Note: We recommend that you complete the remaining steps without a cutting tool installed, without a workpiece in place, and the table lower than the maximum spindle downfeed travel. This will enable you to test and confirm the settings before beginning the actual cutting operation.

NOTICE

To avoid damage to the system gearing, never use the auto-downfeed system with spindle speeds over 1860 RPM.

6. Set the mill for the correct spindle speed, then begin spindle rotation.

NOTICE

To avoid the risk of gear damage, always start spindle rotation before using the auto-downfeed rate selector.

- Select one of the three downfeed rates by pulling the knob of the auto-downfeed rate selector out, position the selector over the appropriate detent, then release the knob. Make sure the pin is firmly seated by attempting to move the selector without pulling the knob out.

Note: Refer to the illustration in **Figure 43** when selecting the downfeed rate.

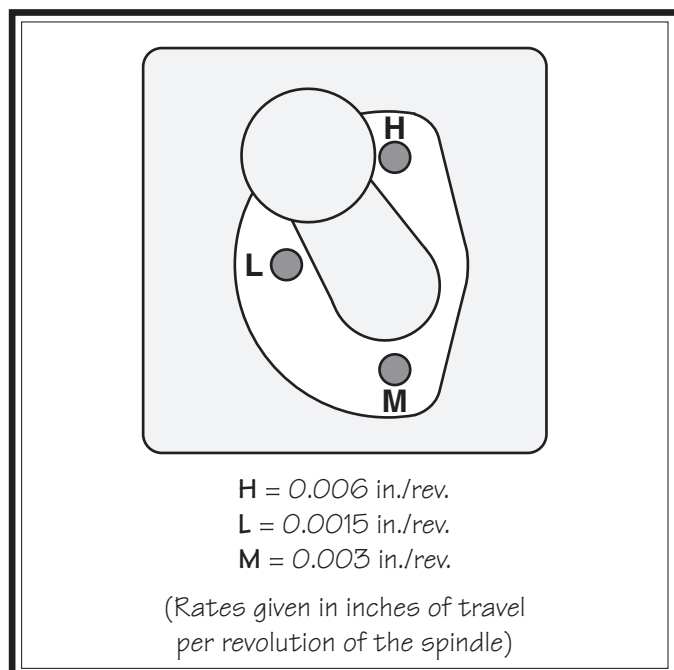

Figure 43. Positions of the auto-downfeed rate selector.

- Use the coarse downfeed lever to lower the spindle slightly until you can pull the clutch lever out to the left and it locks in place, which will start the auto-downfeed spindle travel.

Spindle Brake

NOTICE

To avoid premature wear of the brake system, use the spindle brake **ONLY** after power to the spindle has been turned **OFF**.

After turning the power to the spindle **OFF**, move the brake lever back or forth to bring the spindle to a full stop (see **Figures 44–45**).

To evenly wear the brake shoes, alternate the direction you move the lever when braking.

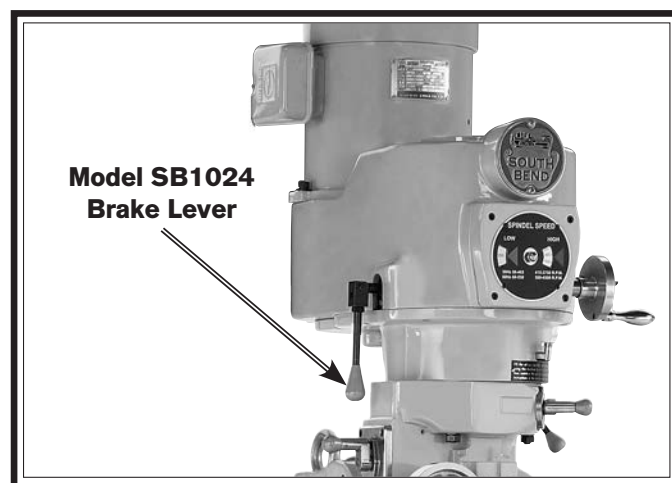

Figure 44. Model SB1024 brake lever location.

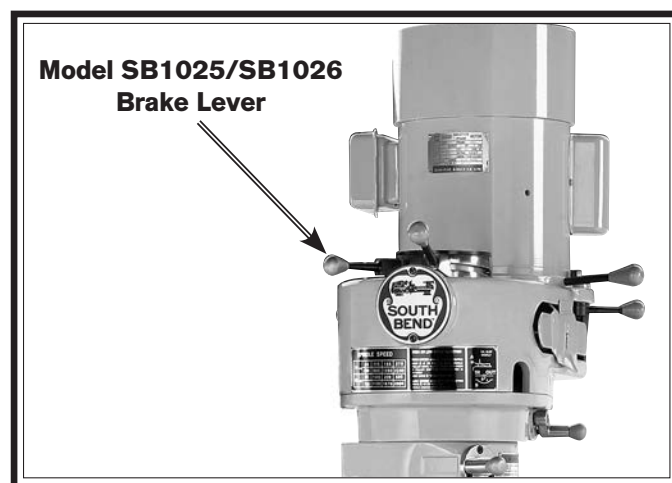

Figure 45. Model SB1025/SB1026 brake lever location.

Loading/Unloading Tooling

The mill is equipped with an R8 spindle taper and a 7/16"-20 x 18 1/2" spindle drawbar that includes one spacer for tool attachment flexibility (see **Figure 46**).

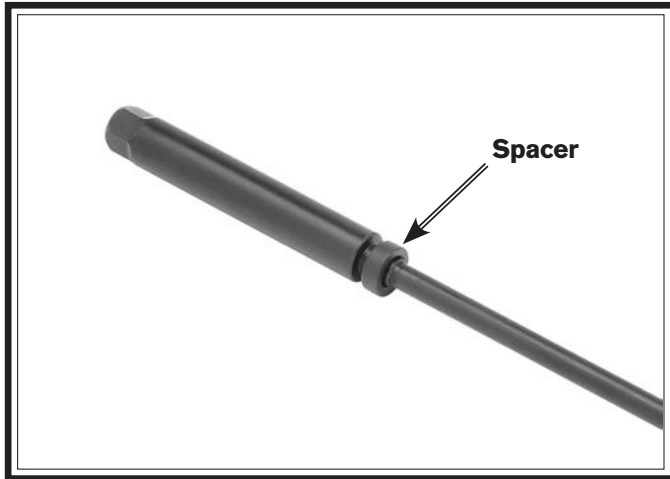

Figure 46. Spindle drawbar and spacer.

Tool Needed	Qty
Wrench 21mm	1

Loading Tooling

1. DISCONNECT MILL FROM POWER!
2. Clean any debris or surface substances from inside the spindle taper and the mating surface of the tooling.

Note: Debris or oil substances can prevent the tooling and spindle from properly mating. This condition can cause excessive vibration, poor cutting results, or tool/workpiece damage.

3. Place the mill in the low spindle speed range to keep the spindle from turning in the next steps.
4. Align the keyway of the tool with the protruding pin inside the spindle taper, then firmly push the tool into the spindle to seat it.

5. With one hand holding the tool in place, insert the drawbar into the spindle from the top of the head, then thread it into the tool (see **Figure 47**).

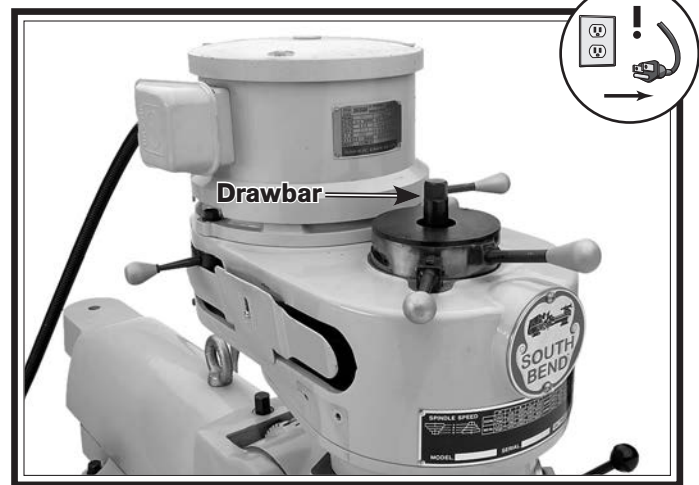

Figure 47. Drawbar loading into the spindle (Model SB1025 shown).

6. Tighten the drawbar until it is snug. Avoid overtightening, as it could make removing the tool difficult.

Unloading Tooling

Tools Needed	Qty
Wrench 21mm	1
Brass Hammer	1

1. DISCONNECT MILL FROM POWER!
2. Place the mill in the low spindle speed range to keep the spindle from turning in the next step.

Note: Make sure that the drawbar has at least three threads engaged with the tooling in the next step to avoid damaging the threads of the drawbar or tool.

3. Loosen the drawbar a couple of turns, then tap the top of it with brass hammer to knock the tool loose at the bottom of the spindle.
4. Support the tool with one hand, then completely unthread the drawbar.

Maintenance Schedule

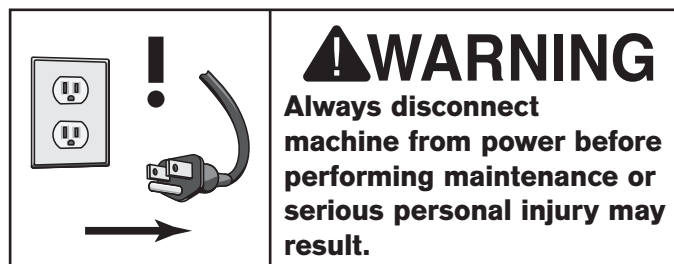

Each operator of this machine is responsible for ensuring proper care of the equipment. We strongly recommend that all operators make a habit of following the daily maintenance procedures.

For optimum performance from this machine, this maintenance schedule must be strictly followed. Use the **Monthly Maintenance Chart** on **Page 50** to ensure this is done.

Ongoing

To maintain a low risk of injury and proper machine operation, if you ever observe any of the items below shut the machine down immediately, disconnect it from power, and fix the problem before continuing operations.

- Loose mounting bolts or fasteners.
- Worn, frayed, cracked, or damaged wires.
- Emergency STOP button not working correctly.
- Missing belt guards.
- Reduction in braking speed or efficiency.
- Coolant not flowing correctly.
- Any other unsafe condition.

Before Beginning Operations

- Make sure the electric box door is closed and properly latched.
- Turn the spindle direction switch to the off (middle) position to prevent spindle startup when connected to power (see **Page 29**).
- Move the spindle speed range selector to the manual (forward) position to prevent the spindle from unexpectedly downfeeding when rotation is started (see **Page 43**).
- Make sure the X-axis power feed is turned **OFF** to prevent unintentional table movement when connected to power (see **Page 31**).
- Check the coolant reservoir in the base for fluid/debris build-up. Clean out if necessary (see **Page 56**).
- Perform lubrications tasks as directed in the **Lubrication** section on **Page 51**.
- Check table movement in all three axes directions for loose/tight gibs. Adjust the gibs if necessary (see **Page 58**).

Daily, After Operations

- Push the emergency STOP button and disconnect the machine from power.
- Vacuum/clean all chips and swarf from table, slides, and base.
- Wipe down all unpainted or machined surfaces with a good quality rust preventative.

South Bend Lathe Co.® Monthly Maintenance Chart for Model SB1024/SB1025/SB1026 Mills

Item	Day	1	2	3	4	5	6	7	8	9	10	11	12	13	14	15	16	17	18	19	20	21	22	23	24	25	26	27	28	29	30	31					
Inspection																																					
Coolant Reservoir																																					
Gib Adjustment																																					
End of Day																																					
Disconnected From Power																																					
Cleaned & Protected																																					
Lubrication																																					
Quill																																					
Table, Saddle, Knee Ways																																					
Speed Range Bearing Sleeve																																					
Headstock Gearing																																					
Ram Ways																																					
Table Elevation Leadscrew																																					
Power Feed Gears																																					

Use this chart to keep track of the maintenance performed on the mill. Cross out or initial the "Day" box for each item on the list. If the box is blacked out, maintenance is not required for that item on that day.

Make copies of this page to use each month. Keep each chart as a maintenance record for the mill.

Month/Year:



(360) 734-1540 • FAX: (360) 676-1075
www.southbendlathe.com

Cleaning

Regular cleaning is one of the most important steps in taking good care of this lathe. Each operator is responsible for cleaning the machine immediately after using it or at the end of the day. We recommend that the cleaning routine be planned into the workflow schedule, so that adequate time is set aside to do the job right.

Typically, the easiest way to clean swarf from the ways and table is to use a wet/dry shop vacuum that is dedicated for this purpose only. The small chips leftover after vacuuming can be wiped up with a slightly oiled rag. Avoid using compressed air to blow off chips, as it may drive them deeper into moving surfaces and could cause sharp chips to fly into your face or hands.

All visible swarf should be removed from the mill during cleaning. Remember, personal neatness gives you personality!

Unpainted & Machined Surfaces

Besides the ways and elevation leadscrew, all other unpainted and machined surfaces should be wiped down daily to keep them rust-free and in top condition. This includes surface you can find that could be vulnerable to rust if left unprotected (this especially includes any parts that may be exposed to water soluble cutting fluids). Typically with these parts, a thin film of oil is all that is necessary for protection.

Lubrication

The mill has numerous moving metal-to-metal contacts that require regular and proper lubrication to ensure efficient and long-lasting operation, and to protect your investment.

Other than the lubrication points covered in this section, all other bearings are internally lubricated and sealed at the factory. Simply leave them alone unless they need to be replaced.

Before performing any lubrication task, **DISCONNECT THE MILL FROM POWER!**

Important: Before adding lubricant, clean the debris and grime from the oil cup or grease fitting and the immediate area to prevent contamination of the oil cups, grease fittings, or new lubricant.

Use the schedule and information in **Figure 48** as a daily guide for lubrication tasks. Follow the referenced sections on the following pages for detailed instructions.

NOTICE

The following recommended lubrication schedule is based on light to medium mill usage. Keeping in mind that lubrication helps to protect the value and operation of the mill, you may need to perform the lubrication tasks more frequently depending on your usage.

Lubrication Task	Frequency (Hours of Operation)	Page Ref.
Quill	4 hrs.	52
Table Ways (One-Shot Oiler)	4–8 hrs.	52
Speed Range Bearing Sleeve (SB1024 Only)	40 hrs.	53
Headstock Gearing	40 hrs.	53
Ram Ways	40 hrs.	54
Table Elevation Leadscrew (Z-Axis)	40 hrs.	54
Power Feed Gears	160 hrs.	54

Figure 48. Recommended lubrication tasks, schedules, and instruction page references.

NOTICE

Failure to follow reasonable lubrication practices as instructed in this manual for the mill could lead to premature failure of the mill and will void the warranty.

Quill

Oil Type Mobil Vactra 2 or ISO 68 Equivalent
 Oil Amount Fill Oil Cup
 Check/Add Frequency 4 hrs. of Operation

Lift the oil cup cap shown in **Figure 49** to add 10 drops of lubricant.



Figure 49. Quill oil cup location.

Table Ways (One-Shot Oiler)

Oil Type Mobil Vactra 2 or ISO 68 Equivalent
 Oil Amount One Pull of Pump Handle
 Check/Add Frequency 4–8 hrs. of Operation

The one-shot oiler is connected to a series of aluminum tubes that carry the lubricant to wear points along the table horizontal and vertical ways. After using the oiler pump handle shown in **Figure 50**, move the table through all paths of movement to evenly distribute the lubricant.

Use the sight glass on the side of the oiler to know when to re-fill the reservoir.

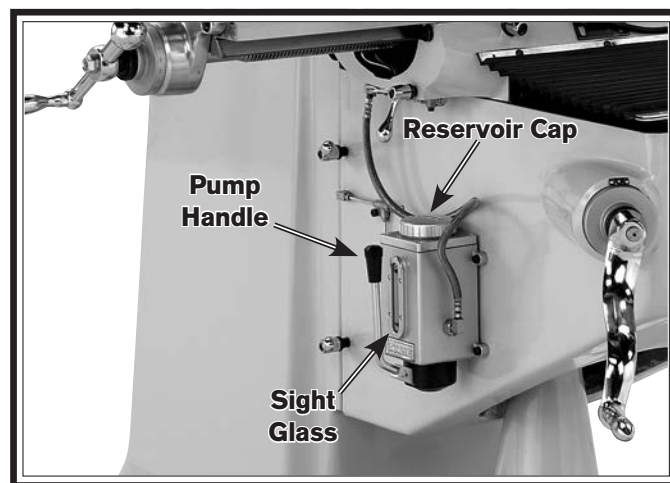

Figure 50. One-shot oiler controls.

Speed Range Bearing Sleeve (SB1024 Only)

Oil Type Mobil Vactra 2 or ISO 68 Equivalent
Oil Amount Fill Oil Cup
Check/Add Frequency 40 hrs. of Operation

Lift the oil cup cap shown in **Figure 51** to add 5 drops of lubricant.

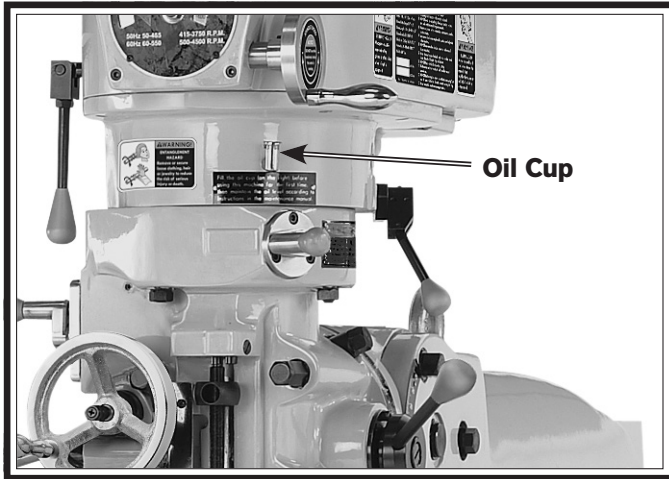

Figure 51. Speed range bearing sleeve (SB1024 only).

Headstock Gearing

Grease Type.....NLGI 2 or Equivalent
Grease AmountTwo Pumps of Grease Gun
Check/Add Frequency40 hrs. of Operation

Add two pumps from a grease gun to the grease fitting for the mill that is shown in **Figures 52–53**.



Figure 52. SB1024 headstock gearing grease fitting.

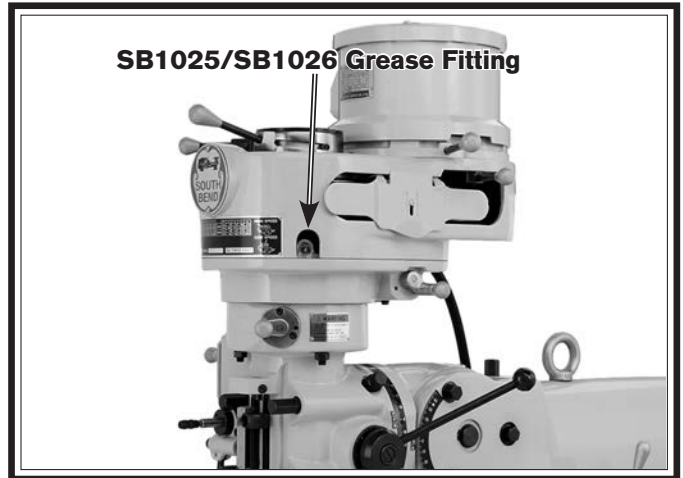

Figure 53. SB1025/SB1026 headstock gearing grease fitting.

Ram Ways

Oil Type Mobil Vactra 2 or ISO 68 Equivalent
 Oil Amount Thin Coat
 Check/Add Frequency 40 hrs. of Operation

Move the ram back and forth as necessary to access the full length of the ways (see **Figure 54**), then use a clean shop rag to apply a thin coat of lubricant.

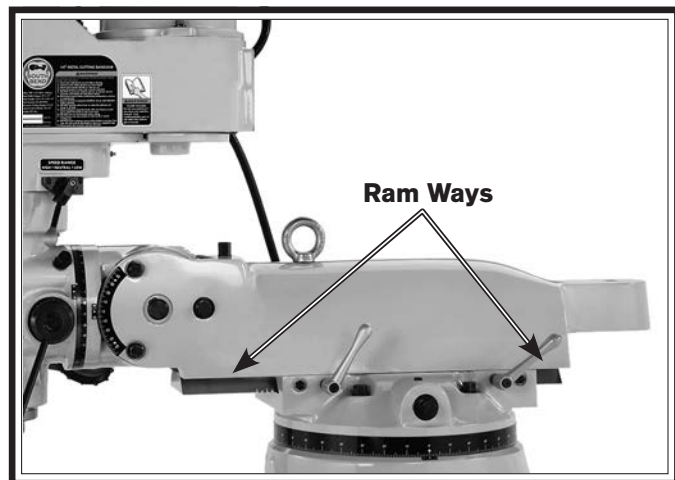

Figure 54. Exposing the ram ways for lubrication.

Head & Ram Rack & Pinion Gear

The interaction between the cast iron surfaces of these devices (see **Figure 55**) produces a dry powder that provides an adequate lubrication.

Do not apply any other lubricant which could produce a stiff compound that may interfere with smooth movement.

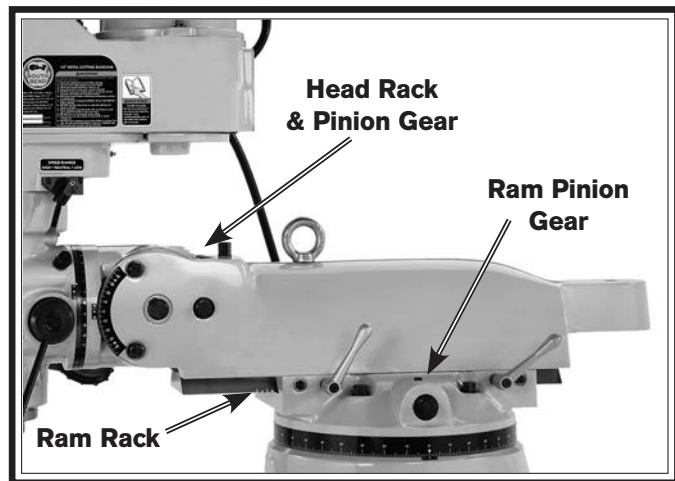

Figure 55. Locations of head and ram rack and pinion gears.

Table Elevation Leadscrew

Grease Type.....NLGI 2 or Equivalent
 Grease Amount Thin Coat
 Check/Add Frequency 40 hrs. of Operation

Elevate the table all the way up, then use mineral spirits to clean any debris and built-up grime from the elevation leadscrew threads. Add one pump from a grease gun to the leadscrew grease fitting shown in **Figure 56**, then run the knee up and down to distribute the grease. Repeat this process until the entire leadscrew



Figure 56. Table elevation leadscrew and grease fitting.

Power Feed Gears

Grease Type.....Medium-Weight Lithium Grease
 Grease AmountTwo Pumps of Grease Gun
 Check/Add Frequency 40 hrs. of Operation

Tool Needed	Qty
Wrench 19mm	1

To lubricate the power feed gears:

1. DISCONNECT MACHINE FROM POWER!

- Remove the hex nut and ball handle from the power unit end of the longitudinal leadscrew (see **Figure 57**).

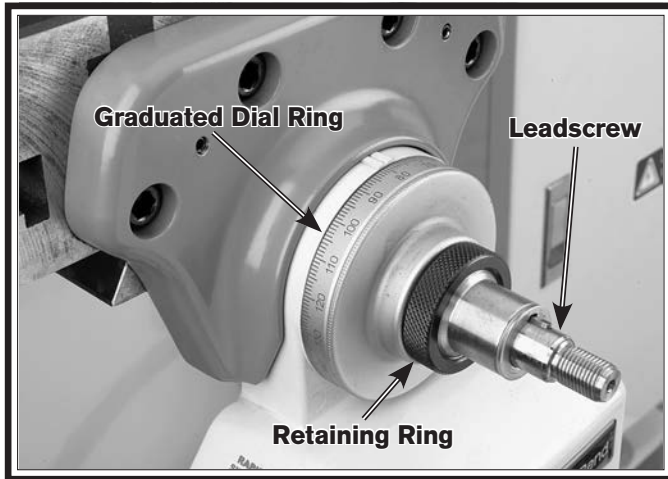

Figure 57. Power feed ball handle removed.

- Unthread and remove the knurled retaining ring and graduated dial ring from the end of the leadscrew.
- Remove the brass bevel gear from the leadscrew, then remove the leadscrew alignment key (see **Figure 58**).

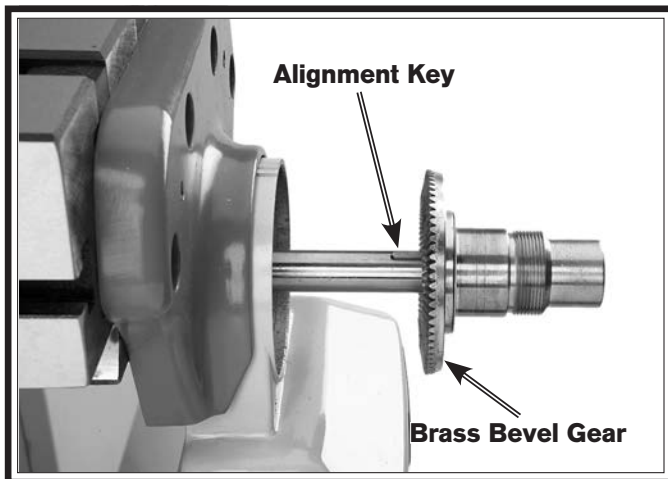

Figure 58. Power feed brass gear and leadscrew alignment key.

- Brush a light coat of lubricant on the teeth of the bevel gear and the smaller drive gear (see **Figure 59**).

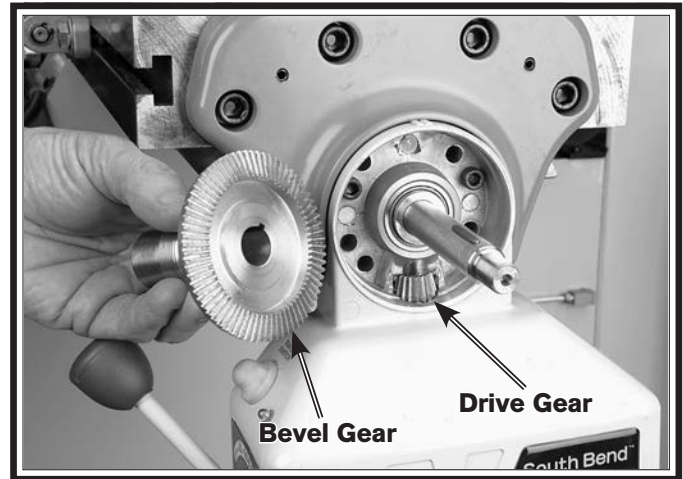
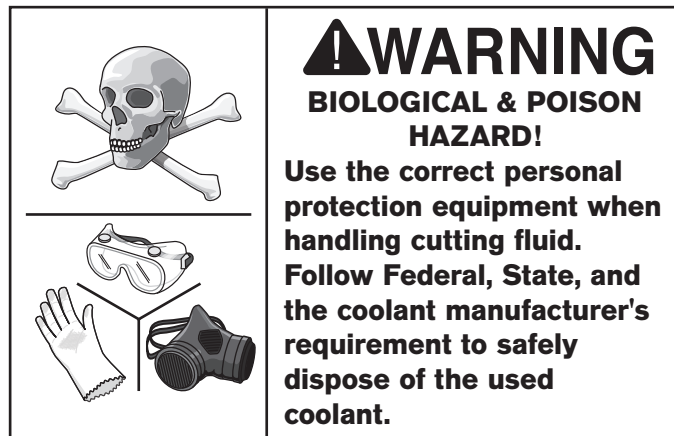

Figure 59. Power feed brass gear and drive gear.

- Replace the leadscrew alignment key, then align the bevel gear keyway and the key as you slide the gear onto the leadscrew and mesh its teeth with the drive gear.
- Replace the graduated dial ring into position and secure it with the knurled retaining ring—do not overtighten.
- Slide the ball handle onto the leadscrew as you align its keyway with the leadscrew alignment key, then secure it with the hex nut removed in **Step 2**.
- Manually move the table with the power feed ball handle to check the gear movement and to distribute the grease on the gears. If the movement is not smooth, repeat **Steps 2–8** until it is.

Cleaning Coolant Reservoir



The cavity in the base of the mill can be used as a coolant reservoir if you choose to install a recirculating coolant pump accessory. This reservoir also catches any coolant and debris that falls from the table and through the screens in the base.

Hazards

As some coolant ages, it develops dangerous microbes which eventually proliferate and create a biological hazard. The risk of exposure to this hazard can be greatly reduced by cleaning out the coolant reservoir on a monthly basis or sooner, if needed based on your daily inspection.

The important thing to keep in mind when working with coolant is to minimize exposure to your skin, eyes, and respiratory system by wearing the proper personal protective equipment, which includes splash-resistant safety glasses, long-sleeve gloves, protective clothing, and a NIOSH-approved respirator.

Cleaning

Tools Needed	Qty
Hex Wrench 3mm	1
Hex Wrench 10mm	1
Catch Pan	1

To clean out the coolant reservoir:

1. DISCONNECT MILL FROM POWER!
2. Put on personal protective equipment.
3. Remove the coolant reservoir access panel from the rear of the column (see **Figure 60**).

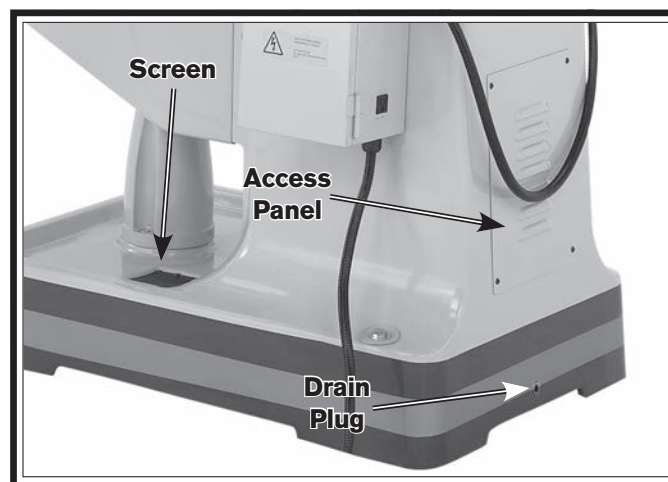

Figure 60. Coolant reservoir access panel and drain plug.

4. Place the catch pan under the drain plug, then remove the plug and allow the fluid to drain into the pan.
5. Clean away debris and grime from the coolant drain screens on the base of the mill.
6. Use rags, scrapers, and cleaning solvent to thoroughly clean out the bottom of the reservoir.

Note: Use a cleaning solvent that is compatible with the type of coolant. For instance, if you are using a water-base coolant, then use a water-base cleaning solvent.

7. When the reservoir is clean and dry, replace the access panel and drain plug.

Machine Storage

To avoid rust problems or corrosion damage, use the following information to protect your investment when storing the mill for any length of time.

- DISCONNECT MILL FROM POWER!
- Lubricate the mill as directed in the **Lubrication** section beginning on **Page 51**.
- Clean out the coolant reservoir in the base of the mill as directed in the **Cleaning Coolant Reservoir** section on **Page 56**.
- Thoroughly clean all unpainted, bare metal surfaces, then coat them with a light weight grease or rust preventative. Take care to ensure these surfaces are completely covered but that the grease or rust preventative is kept off painted surfaces.
- Loosen the belts to prevent them from stretching during storage. Post a reminder on the mill that the belts need to be re-installed or tensioned before resuming operations.
- Place a few moisture absorbing desiccant packs inside the electrical and control panel boxes.
- Cover and place the machine in a dry area that is out of direct sunlight and away from hazardous fumes, paint, solvents, or gas. Fumes and sunlight can bleach or discolor paint and plastic parts.
- At least once a month, start the mill and run all gear-driven components for a few minutes. This will keep the bearings, bushings, gears, and shafts well lubricated and protected from corrosion, especially during the winter months.

Note: If the machine will be out of service for only a short period of time, use way oil or a good grade of medium-weight machine oil (not auto engine oil) in place of the grease or rust preventative.

Adjusting Gibs

Gibs are tapered lengths of metal that are sandwiched between two moving surfaces. Gibs control the gap between these surfaces and how they slide past one another. Correctly adjusting the gibs is critical to producing good milling results.

Tight gibs make table movement more accurate but stiff. Loose gibs make moving the table sloppy but easier to do. The goal of gib adjustment is to remove unnecessary sloppiness without causing the ways to bind.

Gibs are adjusted with a screw on each end of the gib, that move the tapered gib back-and-forth to increase or decrease the friction pressure between the sliding surfaces. The process of properly adjusting the gibs requires trial-and-error and patience.

DISCONNECT MILL FROM POWER BEFORE ADJUSTING THE GIBS!

Make sure all table and knee locks are loose. Then, loosen one gib adjustment screw and tighten the other the same amount to move the gib. Use the ball handles/crank to move the table/knee until you feel a slight drag in that path of movement.

Refer to **Figures 61–63** to identify the locations of the table, saddle, and knee gibs, and one of the two adjustment screws for each.

Note: It will be necessary to remove small parts, such as way wipers and covers, to access the gib adjustment screws.

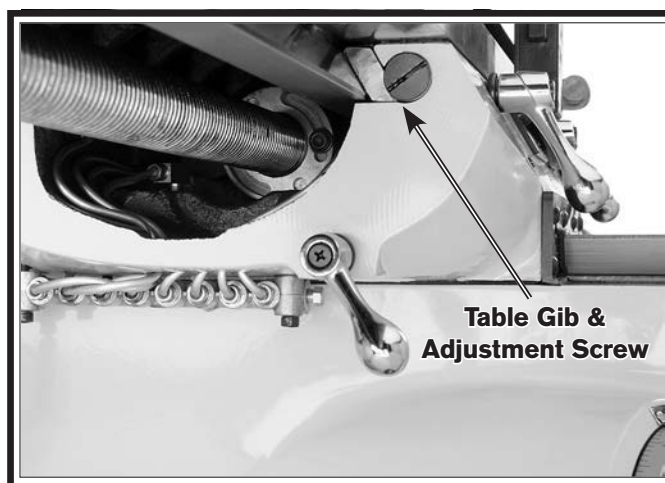

Figure 61. Table gib and adjustment screw underneath the left side of the table.



Figure 62. Saddle gib and adjustment screw.



Figure 63. Knee gib and adjustment screw.

Adjusting Leadscrew Backlash

Leadscrew backlash is the amount of motion the leadscrew rotates before the attached device begins to move.

Although the mill is equipped with double-bronzed longitudinal and cross leadscrew nuts to minimize backlash, leadscrews will always have a certain amount of backlash that will increase with normal wear.

Generally, 0.005"–0.010" leadscrew backlash is acceptable to ensure smooth movement and reduce the risk of premature thread wear. However, if you find it necessary to adjust leadscrew backlash, perform the procedures listed below.

Tools Needed

	Qty
T-Handle Hex Wrench 5mm.....	1
Hex Wrench 3mm	2
Hex Wrench 8mm	1
Wrench 19mm	1

Longitudinal Leadscrew Backlash

1. DISCONNECT MILL FROM POWER!
2. Loosen the two cap screws on the leadscrew nut accessed from underneath the left side of the table, as shown in **Figure 64**.



Figure 64. Longitudinal leadscrew nut and cap screw, as viewed from underneath the left side of the table.

3. Rotate the adjustment plate on the leadscrew nut in small increments, then check the amount of backlash.
4. When you are satisfied with the adjustment, re-tighten the two cap screws.

Cross Leadscrew Backlash

1. DISCONNECT MILL FROM POWER!
2. Remove the hex nut and ball handle from the cross leadscrew.

Note: In the next step, take care not to misplace the leadscrew key as you remove the parts.

3. Unthread and remove the knurled retaining ring, graduated dial ring, and the leadscrew key, as shown in **Figure 65**.



Figure 65. Ball handle, rings, and key removed from the cross leadscrew.

4. Remove the four cap screws from the bearing housing, then slide it off the leadscrew (see **Figure 66**).

Note: It may be necessary to use a dead blow hammer or rubber mallet on the housing to knock it loose.

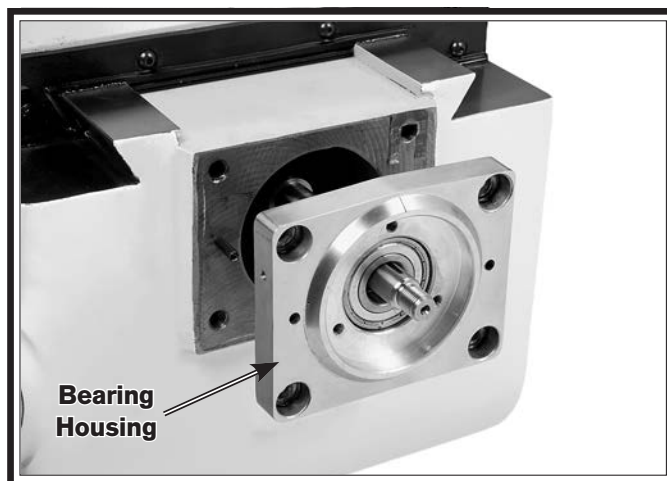

Figure 66. Removing the bearing housing from the cross leadscrew.

5. Loosen the two cap screws on the face of the leadscrew nut shown in **Figure 67**.



Figure 67. Cross leadscrew nut and cap screws.

6. Re-install the key back onto the leadscrew so that you can use the ball handle in the next step.
7. Rotate the adjustment plate on the leadscrew nut in small increments, then check the amount of backlash.
8. When you are satisfied with the adjustment, re-tighten the two cap screws.
9. Re-install the parts previously removed in the reverse order.

If you need replacement parts, or if you are unsure how to do any of the solutions given here, feel free to call us at (360) 734-1540.

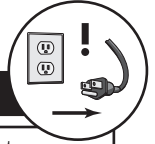

Symptom	Possible Cause	Possible Solution
Machine does not start or a breaker trips.	<ol style="list-style-type: none"> Emergency stop button is pushed in or is at fault. Plug/receptacle is at fault or wired incorrectly. Power supply is switch OFF or is at fault. Motor connection wired incorrectly. ON button or spindle direction switch at fault. Motor windings or motor is at fault. 	<ol style="list-style-type: none"> Rotate the button clockwise until it pops out; replace if necessary. Test for good contacts; correct the wiring. Ensure hot lines have correct voltage on all legs and main power supply is switched ON. Correct motor wiring connections (Pages 66 & 69). Replace faulty ON button or spindle direction switch. Replace motor.
Machine stalls or is overloaded.	<ol style="list-style-type: none"> Machine is undersized for the task. Workpiece alignment is poor. Dull or incorrect cutting tool. Spindle speed is incorrect for the operation. Motor connection wired incorrectly. Plug/receptacle is at fault or wired incorrectly; incorrect voltage coming from power source. Pulley(s) slipping on shaft. Motor bearings at fault. Motor has overheated. Motor is at fault. 	<ol style="list-style-type: none"> Use smaller sharp tooling; reduce the feed rate; reduce the spindle speed; use coolant. Eliminate workpiece binding; use vise or clamps as required for proper workpiece alignment control. Use sharp and correct cutting tool for the operation. Select appropriate spindle speed (Page 37). Correct motor wiring connections (Pages 66 & 69). Test for good contact; correct wiring problems; ensure hot lines have correct voltage on all legs. Replace loose pulley/shaft. Test by rotating shaft; rotation grinding/loose shaft requires bearing replacement. Clean off motor, let cool, and reduce workload. Replace motor.
Machine has vibration or noisy operation.	<ol style="list-style-type: none"> Tool holder or cutter is at fault. Workpiece alignment is poor. Motor or component is loose. Pulley is loose. Machine is incorrectly mounted to floor or sits uneven. Motor fan is rubbing on fan cover. Pulley(s) slipping on shaft. Motor bearings at fault. Gearbox is at fault. 	<ol style="list-style-type: none"> Replace out-of-round tool holder; replace/re-sharpen cutter; use appropriate feed rate spindle speed. Eliminate workpiece binding; use vise or clamps as required for proper workpiece alignment control. Inspect replace stripped or damaged bolts/nuts and re-tighten with thread locking fluid. Re-align/replace shaft, pulley, set screw, and key as required. Re-tighten/replace mounting bolts in floor; relocate/shim machine. Replace dented fan cover or fan. Replace loose pulley/shaft. Test by rotating shaft; rotation grinding/loose shaft requires bearing replacement. Rebuild gearbox for bad gear(s)/bearing(s).

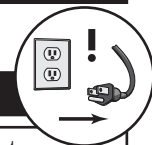

Symptom	Possible Cause	Possible Solution
Tool slips in collect.	<ol style="list-style-type: none"> 1. Collet is not fully drawn into spindle taper. 2. Wrong size collet. 3. Debris on mating surfaces of collet and spindle. 4. Excessive depth of cut. 	<ol style="list-style-type: none"> 1. Snug up the drawbar to fully seat the collet. 2. Use correct collect for tool shank diameter. 3. Remove oil and debris from mating surfaces, then re-install. 4. Decrease depth of cut and allow chips to clear.
Tool breakage.	<ol style="list-style-type: none"> 1. Spindle speed too slow/feed rate too fast. 2. Tool getting too hot. 3. Excessive depth of cut. 	<ol style="list-style-type: none"> 1. Use correct spindle speed and feed rate (Page 37). 2. Use coolant; reduce spindle speed/feed rate (Page 37). 3. Decrease depth of cut and allow chips to clear.
Workpiece chatters or vibrates during operation.	<ol style="list-style-type: none"> 1. Table/saddle/knee locks not tight. 2. Workpiece not securely clamped to table or mill vise. 3. Tool not secure or is damaged. 4. Spindle speed too fast/feed rate too slow. 5. Gibs are too loose. 	<ol style="list-style-type: none"> 1. Tighten all locks on mill that are not associated with necessary table movement for the operation. 2. Check that clamping is tight and sufficient for the operation; make sure mill vise is clamped tight to table. 3. Properly secure the tool; replace if damaged. 4. Use correct spindle speed and feed rate (Page 37). 5. Properly adjust gibs (Page 58).
Table hard to move.	<ol style="list-style-type: none"> 1. Table/saddle/knee locks are tightened down. 2. Chips have loaded up on the ways. 3. Ways are dry and in need of lubrication. 4. Gibs are too tight. 	<ol style="list-style-type: none"> 1. Full loosen locks needed for movement. 2. Frequently clean away chips from the ways that build up during operation. 3. Use the one-shot oiler (Page 52). 4. Properly adjust gibs (Page 58).
Bad surface finish.	<ol style="list-style-type: none"> 1. Wrong spindle speed/feed rate. 2. Dull/damaged tool; wrong tool for operation. 3. Wrong spindle rotation direction for tool. 4. Workpiece not securely clamped to table or mill vise. 5. Gibs are too loose. 	<ol style="list-style-type: none"> 1. Use correct spindle speed and feed rate (Page 37). 2. Sharpen/replace tool; use correct tool for operation. 3. Check for proper spindle rotation direction for tool. 4. Check that clamping is tight and sufficient for the operation; make sure mill vise is clamped tight to table. 5. Properly adjust gibs (Page 58).
Power feed chatters or grinds during operation.	<ol style="list-style-type: none"> 1. Brass bevel gear is not meshed with the drive gear. 2. Power feed unit is at fault 	<ol style="list-style-type: none"> 1. Remove parts from the power feed side of the longitudinal leadscrew to ensure the bevel gear is properly meshed; make sure the ball handle nut is tight. 2. Replace.

Electrical Safety Instructions

These pages are accurate at the time of printing. In the constant effort to improve, however, we may make changes to the electrical systems of future machines. Study this section carefully. If you see differences between your machine and what is shown in this section, call Technical Support at (360) 734-1540 for assistance BEFORE making any changes to the wiring on the machine.

- 1. Shock Hazard:** Working on wiring that is connected to a power source is extremely dangerous. Touching electrified parts will result in personal injury including but not limited to severe burns, electrocution, or death. Disconnect the power from the machine before servicing electrical components!
- 2. Wire Connections:** All connections must be tight to prevent wires from loosening during machine operation. Double-check all wires disconnected or connected during any wiring task to ensure tight connections.
- 3. Modifications:** Using aftermarket parts or modifying the wiring beyond what is shown in the diagram may lead to unpredictable results, including serious injury or fire.
- 4. Motor Wiring:** The motor wiring shown in these diagrams is current at the time of printing, but it may not match your machine. Always use the wiring diagram inside the motor junction box.
- 5. Circuit Requirements:** You MUST follow the requirements at the beginning of this manual when connecting your machine to a power source.
- 6. Capacitors/Inverters:** Some capacitors and power inverters store an electrical charge for up to 10 minutes after being disconnected from the power source. To reduce the risk of being shocked, wait at least this long before working on capacitors.
- 7. Wire/Component Damage:** Damaged wires or components increase the risk of serious personal injury, fire, or machine damage. If you notice that any wires or components are damaged while performing a wiring task, replace those wires or components before completing the task.
- 8. Experiencing Difficulties:** If you are experiencing difficulties understanding the information included in this section, contact our Technical Support at (360) 734-1540.

Wiring Overview

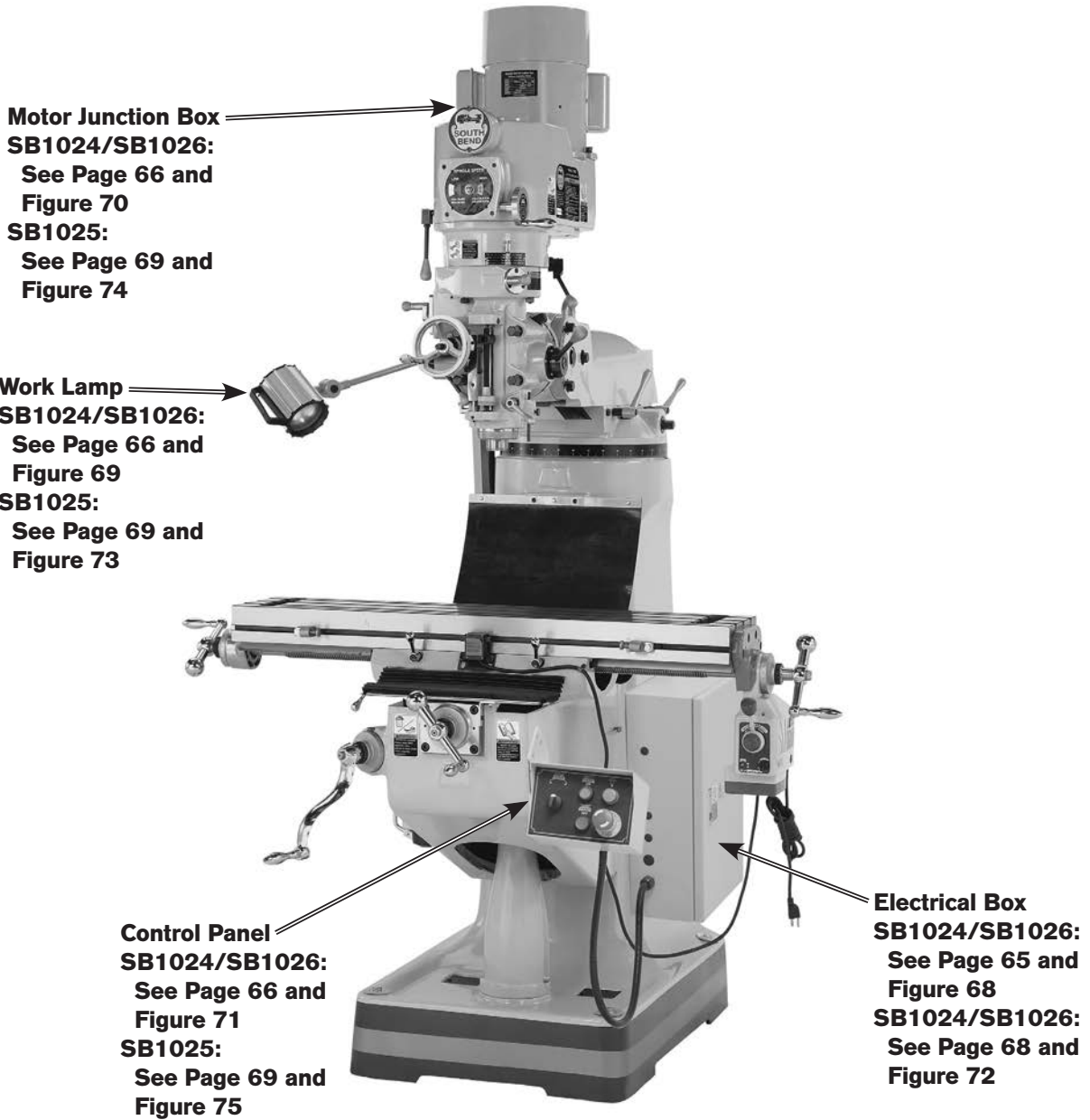

WIRING DIAGRAM COLOR KEY

BLACK — Bk —	BLUE WHITE — Bw —	RED — Rd —	PINK — Pk —	WHITE — Wt —
BLUE — Bl —	GREEN — Gn —	LIGHT BLUE — Lb —	PURPLE — Pu —	YELLOW GREEN — Yg —
BROWN — Br —	GRAY — Gy —	ORANGE — Or —	TUR-QUIOSE — Tu —	YELLOW — Yl —

NOTICE: The photos and diagrams included in this section are best viewed in color. You can see them in color at www.southbendlathe.com.

SB1024/SB1026 Electrical Box

**SB1024/26
Electrical
Box, See
Figure 71**

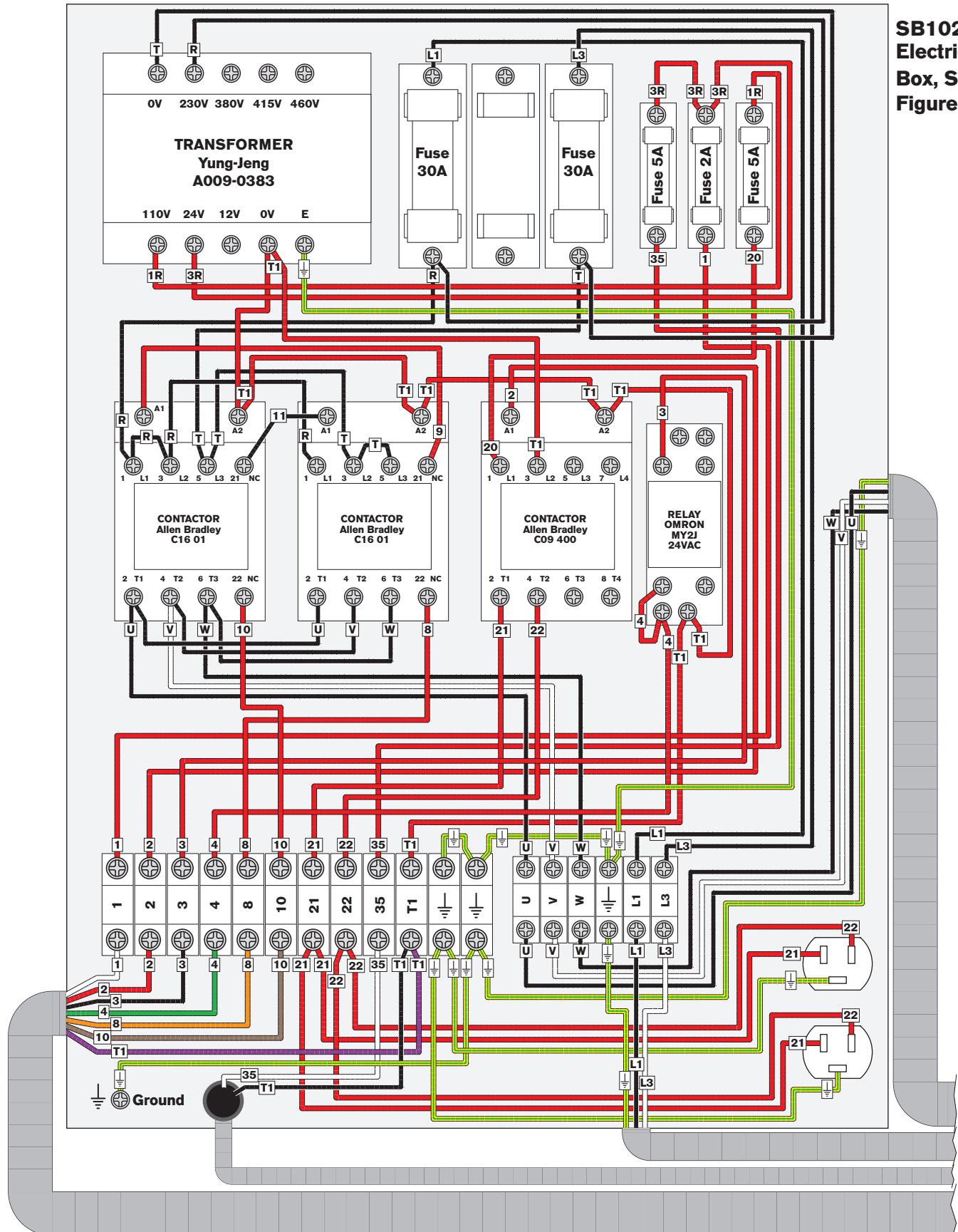

To Page 66

SB1024/SB1026 Electrical Components

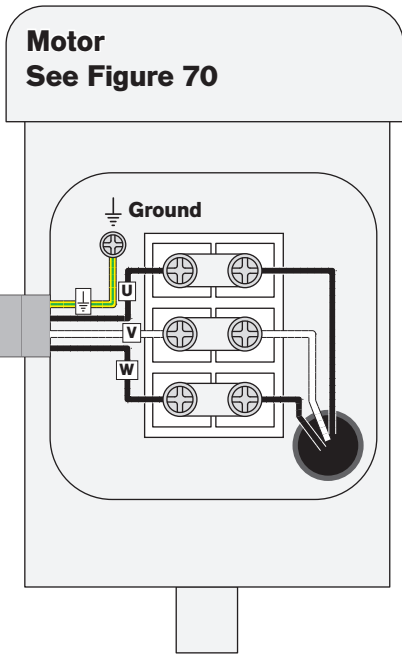

Work Lamp
See Figure 69

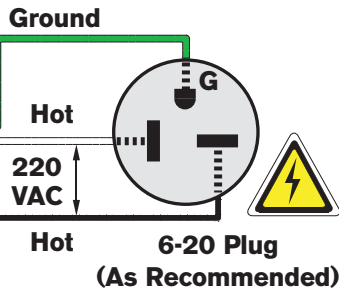
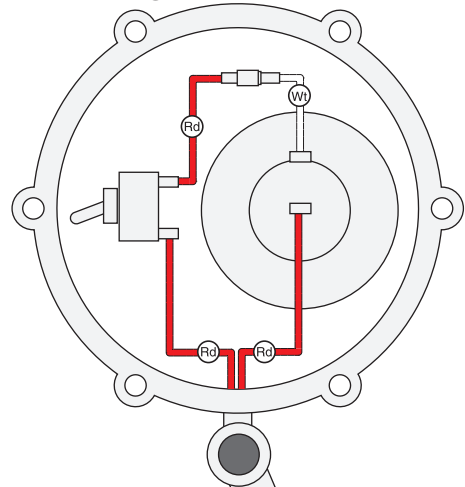

Control Panel (Viewed From Behind)
See Figure 71

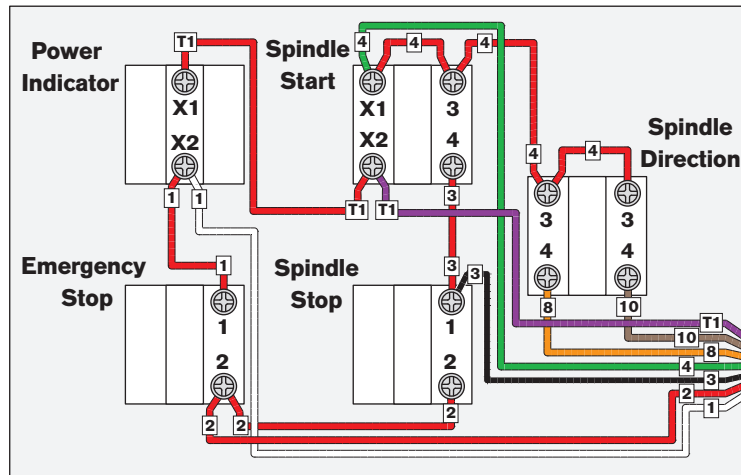

To Page 65



SB1024/SB1026 Electrical Component Pictures



Figure 68. Electrical box.



Figure 70. Motor junction box.

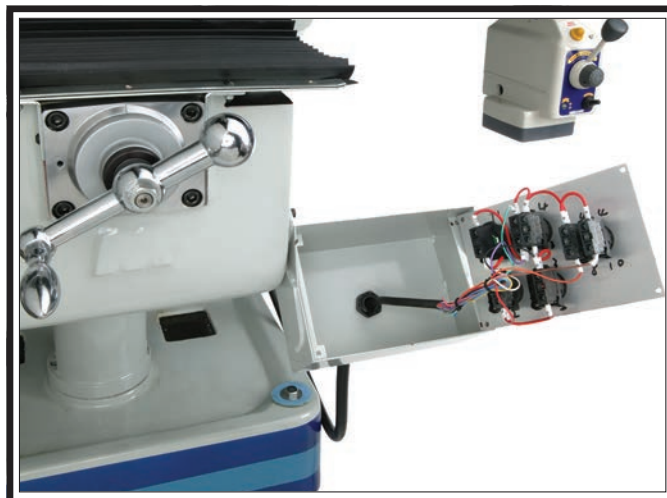
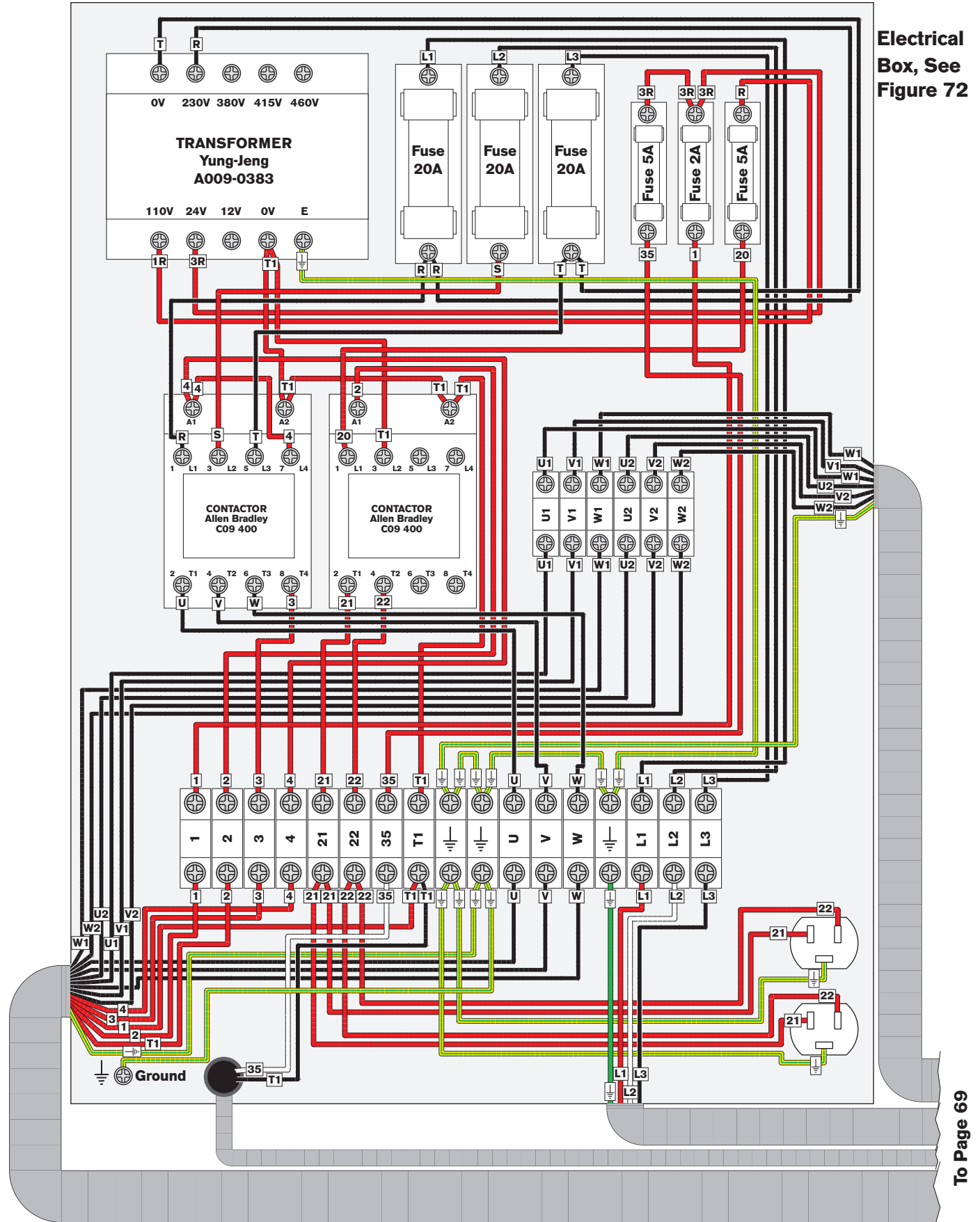

Figure 71. Control panel.



Figure 69. Work lamp.

SB1025 Electrical Box



To Page 69

SB1025 Electrical Components

Motor
See Figure 74

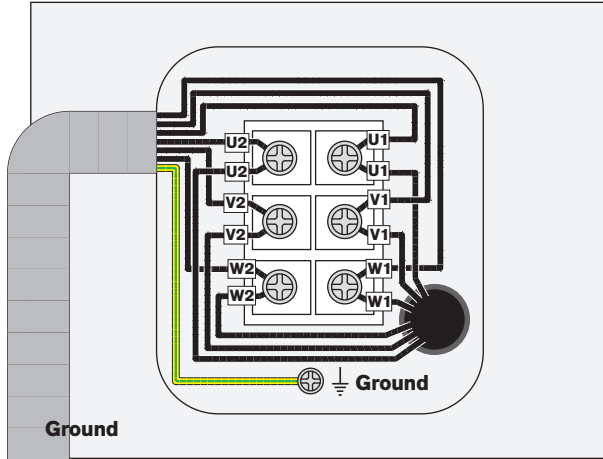

Work Lamp
See Figure 73

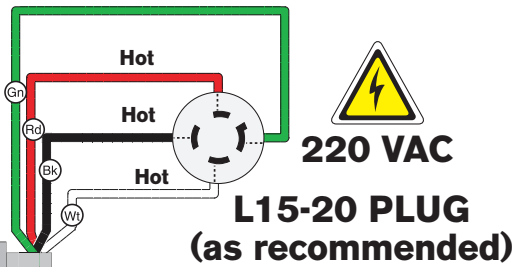
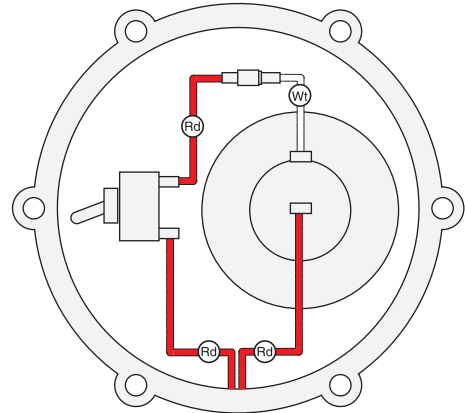

Control Panel (Viewed From Behind)
See Figure 75

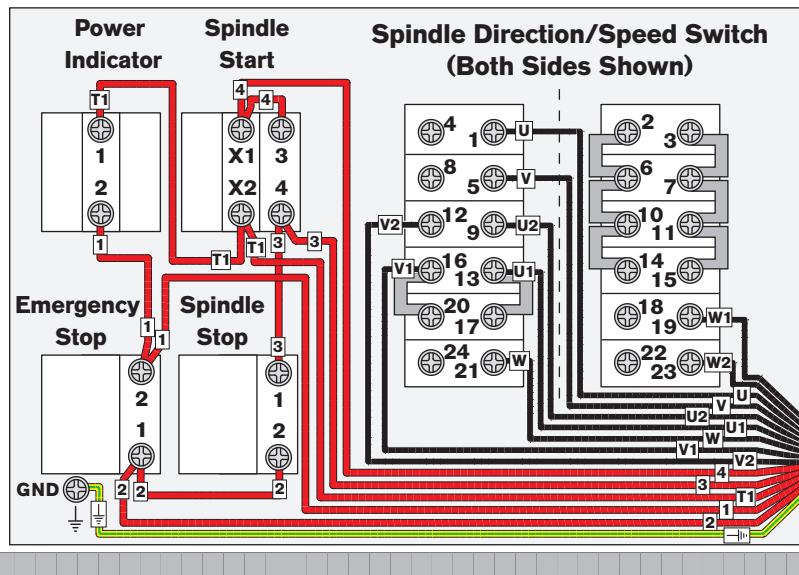

To Page 68.

SB1025 Electrical Component Pictures



Figure 72. SB1025 Electrical box.



Figure 74. SB1025 Motor junction box.

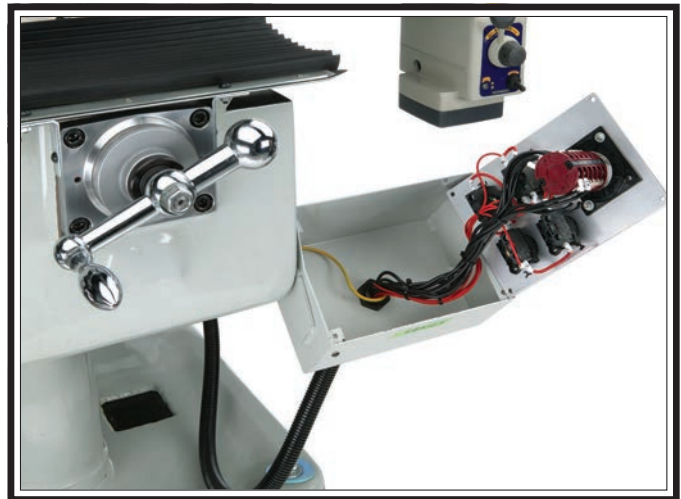

Figure 75. SB1025 Control panel.



Figure 73. SB1025 Work lamp.

Headstock Parts List

REF	PART #	DESCRIPTION
1	PSB10240449	ROUND KNOB 3/8-16
2	PSB10240002	PINION SHAFT LEVER
3	PSB10240003	PINION SHAFT HUB
4	PSTB004	STEEL BALL 3/16
5	PSB10240005	COMPRESSION SPRING
6	PSS05	SET SCREW 5/16-18 X 1/4
7	PSB10240007	HUB RETAINER
8	PSB10240008	PINION SHAFT HUB SLEEVE
9	PCAP33M	CAP SCREW M5-.8 X 12
10	PSB10240010	RETURN SPRING COVER
11	PSB10240011	FLAT COIL SPRING
12	PK155M	KEY 3 X 3 X 18
13	PSB10240013	RETURN SPRING STUD
14	PSB10240014	QUILL PINION SHAFT 10T/16T
15	PRIV001M	FLUTED RIVET 2 X 5MM STEEL
17	PSB10240017	ZERO SCALE
18	PSB10240018	ROUND KNOB 1/4-20
19	PSB10240019	SHIFT CRANK
20	PSS11	SET SCREW 1/4-20 X 1/4
21	PSB10240021	COMPRESSION SPRING 9 X 1 X 24MM
22	PSB10240022	GEAR SHIFT PLUNGER
23	PSB10240023	SHIFT SLEEVE
24	PSB10240024	WORM GEAR CRADLE THROW-OUT
25	PSB10240025	WORM SHAFT
26	PSS01M	SET SCREW M6-1 X 10
27	PK102M	KEY 4 X 4 X 18
28	PSB10240028	WORM GEAR
29	PSB10240029	CLUSTER GEAR RETAINER
30	PSB10240030	FEED CLUSTER GEAR 17T/28T/22T
31	PRO6M	EXT RETAINING RING 16MM
32	PSB10240032	BEVEL GEAR BUSHING
33	PSB10240033	BEVEL GEAR THRUST SPACER
34	PSB10240034	FEED REVERSE BEVEL PINION
35	PK53M	KEY 3 X 3 X 45
36	PSB10240037A	FEED ENGAGE PIN
37A	PSB10240037A	WORM GEAR CRADLE ASSEMBLY
37	PSB10240037A	WORM GEAR CRADLE
38	PSS26M	SET SCREW M5-.8 X 6
39	PCAP04M	CAP SCREW M6-1 X 10
40	PW03M	FLAT WASHER 6MM
41	PSB10240037A	WORM GEAR SPACER
42	PSB10240037A	FEED DRIVE WORM GEAR 20T
43	PSB10240037A	WORM CRADLE BUSHING
44	PK103M	KEY 3 X 3 X 12
45	PSB10240037A	FEED REVERSE BEVEL PINION
46	PCAP30	CAP SCREW 5/16-18 X 1/2
47	PSB10240037A	BEVEL GEAR FLAT WASHER 8MM
48	PSB10240037A	FEED BEVEL GEAR 24T
49	PK03M	KEY 3 X 3 X 8

REF	PART #	DESCRIPTION
50	PSB10240037A	CLUSTER GEAR SHAFT 18T/12T
51	PSB10240037A	FEED DRIVE CLUSTER GEAR 23T
52	PSB10240037A	NEEDLE BEARING BZ66Z TIMKEN
53	PSB10240053	REVERSE CLUTCH ROD
54	PSB10240055A	FEED REVERSE BUSHING
55A	PSB10240055A	FEED REVERSE BEVEL GEAR ASSY
55	PSB10240055A	FEED REVERSE BEVEL GEAR
56	PSB10240056	FEED REVERSE CLUTCH
57	PRP42M	ROLL PIN 3 X 20
58	PRO3M	EXT RETAINING RING 12MM
59	PSB10240059	FEED WORM SHAFT BUSHING
60	PK39M	KEY 3 X 3 X 10
61	PK52M	KEY 3 X 3 X 15
62	PSB10240062	WORM
63	PSB10240063	BUSHING
64	PCAP06M	CAP SCREW M6-1 X 25
65	PSS01M	SET SCREW M6-1 X 10
66	PSB10240066	FEED GEAR SHIFTER FORK
67	PSB10240067	CLUSTER GEAR SHIFT CRANK
68	PSB10240068	FEED SHIFT ROD
69	PSB10240069	CLUSTER GEAR COVER
70	PSB10240070	QUILL PINION SHAFT BUSHING
71	PSB10240071	OVERLOAD CLUTCH WORM GEAR 30T
72	PRO5M	EXT RETAINING RING 15MM
73	PSB10240073A	PINION OVERLOAD CLUTCH SHAFT
73A	PSB10240073A	PINION OVERLOAD CLUTCH ASSY
74	PSB10240073A	OVERLOAD CLUTCH
75	PSB10240073A	COMPRESSION SPRING 40 X 46 X 3.5MM
76	PSS05M	SET SCREW M5-.8 X 10
77	PSB10240073A	PINION OVERLOAD CLUTCH COLLAR
78	PSB10240078	CLUTCH RING
79	PSB10240079	FLAT WASHER 10 X 22 X 3MM
80	PRO1M	EXT RETAINING RING 10MM
81	PSB10240081	CLUTCH RING SCREW M5-.8 X 16
82	PSB10240082	OVERLOAD CLUTCH TRIP LEVER
83	PRP03M	ROLL PIN 5 X 20
84	PSB10240084	CLUTCH ARM COVER
85	PCAP79M	CAP SCREW M5-.8 X 35
86	PNO5	HEX NUT 1/4-20
87	PSS06	SET SCREW 1/4-20 X 3/4
88	PSB10240088	COMPRESSION SPRING 1.2 X 6.6 X 42MM
89	PSB10240089	OVERLOAD CLUTCH PLUNGER
90	PSB10240090	OIL CUP 1/8"
91	PSB10240091	TRIP PLUNGER BUSHING
92	PSB10240092	FEED TRIP PLUNGER
93	PSB10240093	FEED TRIP LEVER
94	PSB10240094	TRIP LEVER SCREW M6-1 X 22.5
95	PNO4M	HEX NUT M4-.7
96	PSS49M	SET SCREW M4-.7 X 16

Headstock Parts List

REF	PART #	DESCRIPTION
97	PSB10240097	KNURLED KNOB SCREW M6-1 X 15
98	PSB10240098	SCRIBING LEVER
99	PSB10240099	REVERSE TRIP BALL LEVER SCREW
100	PSB10240100	FEED REVERSE TRIP PLUNGER
101	PSB10240101	REVERSE TRIP BALL LEVER
102	PSB10240102	QUILL STOP KNOB
103	PSB10240105A	UPPER QUILL MICRO STOP
104	PSB10240105A	LOWER QUILL MICRO STOP
105A	PSB10240105A	QUILL MICRO STOP ASSEMBLY
105	PSB10240105A	QUILL MICRO STOP SHAFT
106	PCAP105	CAP SCREW 3/8-16 X 5/8
107A	PSB10240107A	STOP TRIP BAR ASSEMBLY
107	PSB10240107A	STOP SHAFT TRIP BAR
108	PSB10240107A	COMPRESSION SPRING
109	PSB10240107A	STOP SHAFT TRIP SHAFT
110	PRP61M	ROLL PIN 3 X 12
111	PSB10240107A	STOP SHAFT END CAP
112	PRPO2M	ROLL PIN 3 X 16
113	PSB10240107A	TRIP BAR SET SCREW
114	PSB10240107A	STOP SHAFT PLUNGER
115	PSB10240115	FEED TRIP BRACKET

REF	PART #	DESCRIPTION
116	PCAP02M	CAP SCREW M6-1 X 20
117	PSB10240117	STOP SHAFT TRIP LEVER
118	PSB10240118	HANDWHEEL CLUTCH
119	PSTB004M	STEEL BALL 5MM
120	PSB10240120	COMPRESSION SPRING
121	PS617M	SET SCREW M8-1.25 X 6
122	PSB10240122	QUILL DEPTH SCALE
123	PS17M	PHLP HD SCR M4-.7 X 6
124	PSB10240124	FINE DOWNFEED HANDWHEEL
125	PSB10240125	HANDWHEEL HANDLE
126	PEC13M	E-CLIP 5MM
127A	PSB10240127A	KNURLED SLEEVE ASSEMBLY
129	PSB10240129	QUILL LOCK NUT M18-2.5
130	PSB10240130	QUILL LOCK SLEEVE
133A	PSB10240133A	LOCK HANDLE ASSEMBLY
135	PSB10240135	HEAD ROTATION LOCK BOLT 1/2-13 X 6-1/4
136	PSB10240136	LOWER CLAMPING BOLT SPACER
137	PSB10240137	LOCK BOLT FLAT WASHER
138	PSB10240138	LOCK BOLT HEX NUT 1/2-13
139	PSB10240139	QUILL HOUSING

Quill

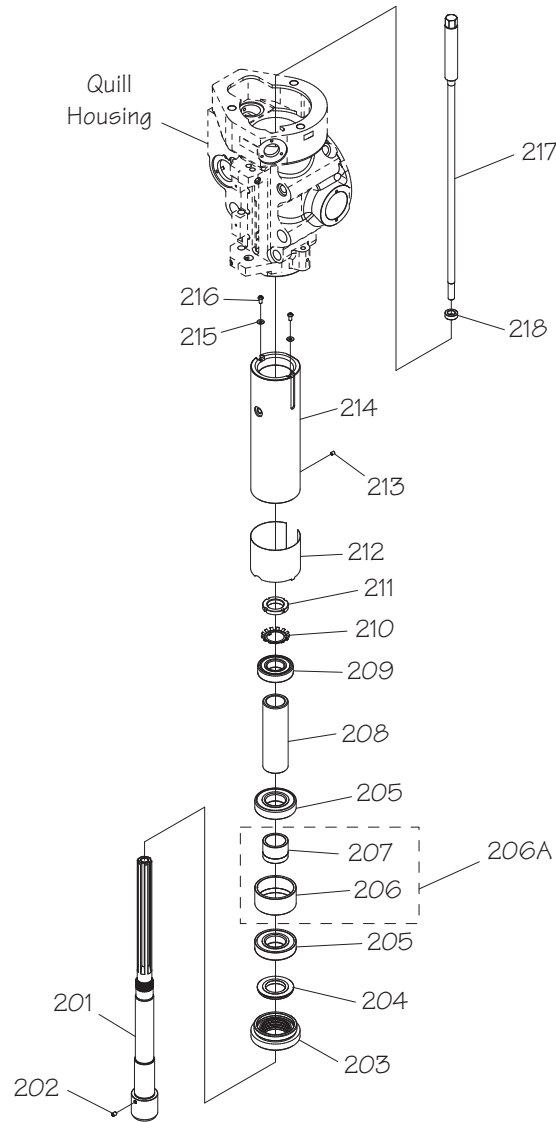

REF	PART #	DESCRIPTION
201	PSB10240201	SPINDLE R8
202	PSS03M	SET SCREW M6-1 X 8
203	PSB10240203	QUILL END CAP
204	PSB10240204	QUILL SEAL
205	PSB10240205	ANGULAR CONTACT BEARING 7207 P4
206A	PSB10240206A	BEARING SPACER ASSEMBLY
206	PSB10240206A	BEARING SPACER
207	PSB10240206A	BEARING SPACER
208	PSB10240208	SLEEVE
209	P6206ZZ	BALL BEARING 6206ZZ

REF	PART #	DESCRIPTION
210	PSB10240210	SPANNER LOCK WASHER
211	PSB10240211	SPANNER NUT
212	PSB10240212	QUILL SKIRT
213	PSS26M	SET SCREW M5-.8 X 6
214	PSB10240214	QUILL
215	PW02M	FLAT WASHER 5MM
216	PS09M	PHLP HD SCR M5-.8 X 10
217	PSB10240217	DRAWBAR 7/16-20 X 18-1/2
218	PSB10240218	DRAWBAR WASHER

SB1024 Gearbox

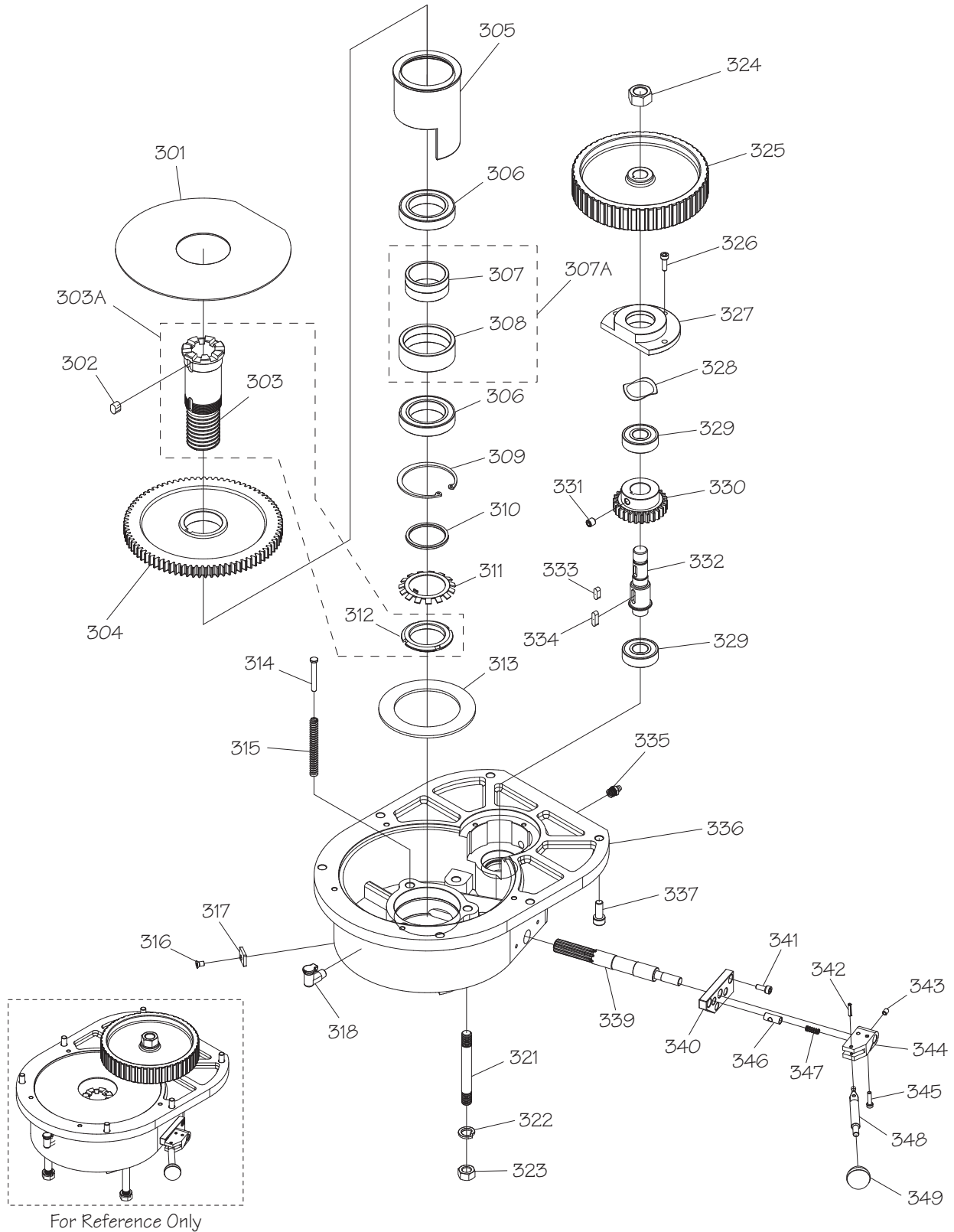

SB1024 Gearbox Parts List

REF	PART #	DESCRIPTION
301	PSB10240301	GEARBOX PLATE
302	PK70M	KEY 8 X 8 X 12
303A	PSB10240303A	SPINDLE GEAR HUB ASSEMBLY
303	PSB10240303A	SPINDLE GEAR HUB
304	PSB10240304	SPINDLE BULL GEAR
305	PSB10240305	BEARING SLEAVE
306	P6908W-N	DEEP GROOVE BALL BEARING 6908W NSK
307A	PSB10240307A	BEARING SPACER ASSEMBLY
307	PSB10240307A	BULL GEAR BEARING SPACER
308	PSB10240307A	BULL GEAR BEARING SPACER
309	PR38M	INT RETAINING RING 62MM
310	PSB10240310	WAVY SPRING WASHER
311	PSB10240311	SPANNER LOCK WASHER
312	PSB10240303A	SPANNER NUT
313	PSB10240313	BEARING SLEAVE WASHER
314	PSB10240314	STEP PIN
315	PSB10240315	COMPRESSION SPRING
316	PFH71M	FLAT HD CAP SCR M5-.8 X 8
317	PSB10240317	INSERT
318	PSB10240090	OIL CUP 1/8"
321	PSB10240321	DOUBLE END HOUSING STUD
322	PLW05	LOCK WASHER 7/16
323	PN19	HEX NUT 7/16-14
324	PNO9	HEX NUT 5/8-18

REF	PART #	DESCRIPTION
325	PSB10240325	BELT PULLEY GEAR
326	PCAP24M	CAP SCREW M5-.8 X 16
327	PSB10240327	BULL GEAR PINION BEARING CAP
328	PSB10240328	WAVY SPRING WASHER
329	P6203W-N	DEEP GROOVE BALL BEARING 6203W NSK
330	PSB10240330	PINION GEAR 30T
331	PS620M	SET SCREW M8-1.25 X 8
332	PSB10240332	PINION GEAR SHAFT
333	PK19M	KEY 5 X 5 X 14
334	PK14M	KEY 5 X 5 X 18
335	PSB10240335	STRAIGHT GREASE FITTING 1/8 PT
336	PSB10240336	GEARBOX HOUSING
337	PCAP14M	CAP SCREW M8-1.25 X 20
339	PSB10240339	BULL GEAR SHIFT PINION
340	PSB10240340	HI-LOW DETENT PLATE
341	PCAP33M	CAP SCREW M5-.8 X 12
342	PRP02M	ROLL PIN 3 X 16
343	PS626M	SET SCREW M5-.8 X 6
344	PSB10240344	HI-LOW PINION BLOCK
345	PCAP16M	CAP SCREW M4-.7 X 16
346	PSB10240346	HI-LOW DETENT PLUNGER
347	PSB10240347	COMPRESSION SPRING
348	PSB10240348	HI-LOW LEVER
349	PSB10240349	ROUND KNOB 1/4-20

SB1025/SB1026 Gearbox

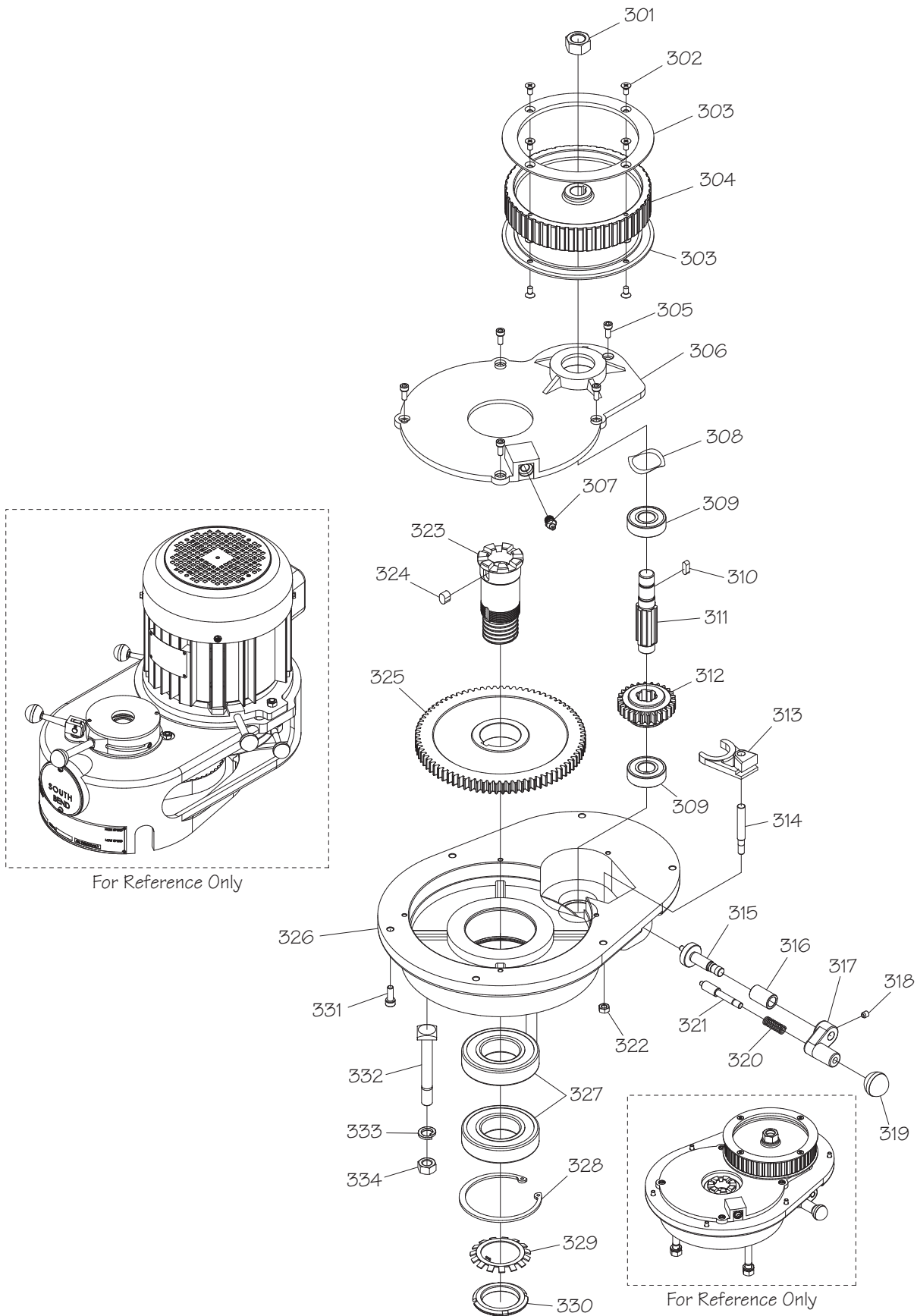

SB1025/SB1026 Gearbox Parts List

REF	PART #	DESCRIPTION
301	PNO4	HEX NUT 5/8-11
302	PFH07M	FLAT HD SCR M5-.8 X 10
303	PSB10250303	PULLEY FLANGE
304	PSB10250304	TIMING BELT PULLEY
305	PCAP33M	CAP SCREW M5-.8 X 12
306	PSB10250306	GEARBOX COVER
307A	PSB10240307A	BEARING SPACER ASSEMBLY
307	PSB10240307A	GREASE FITTING 1/8
308	PSB10240307A	WAVE SPRING WASHER
309	P6203VV-N	DEEP GROOVE BALL BEARING 6203VV NSK
310	PK20M	KEY 5 X 5 X 15
311	PSB10250311	PINION GEAR SHAFT
312	PSB10250312	PINION GEAR 26T
313	PSB10250313	BACK GEAR SHIFTER FORK
314	PSB10250314	STEPPED PIN
315	PSB10250315	BACK GEAR SHIFT CRANK
316	PSB10250316	BACK GEAR SHIFT BUSHING
317	PSB10250317	SHIFT CRANK

REF	PART #	DESCRIPTION
318	PS502M	SET SCREW M6-1 X 6
319	PSB10240018	ROUND KNOB 1/4-20
320	PSB10250320	COMPRESSION SPRING
321	PSB10250321	GEAR SHIFT PLUNGER
322	PSB10250322	SPECIAL HARDENED HEX NUT 1/4-20
323	PSB10250323	SPLINE GEAR HUB
324	PK70M	KEY 8 X 8 X 12
325	PSB10250325	SPINDLE BULL GEAR
326	PSB10250326	GEARBOX HOUSING
327	P6908VV-N	DEEP GROOVE BALL BEARING 6908VV NSK
328	PSB10250328	INT RETAINING RING
329	PSB10250329	SPANNER LOCK WASHER
330	PSB10250330	SPANNER NUT
331	PCAP01M	CAP SCREW M6-1 X 16
332	PSB10250332	T-BOLT
333	PLW05	LOCK WASHER 7/16
334	PN19	HEX NUT 7/16-14

SB1024 Belt Housing

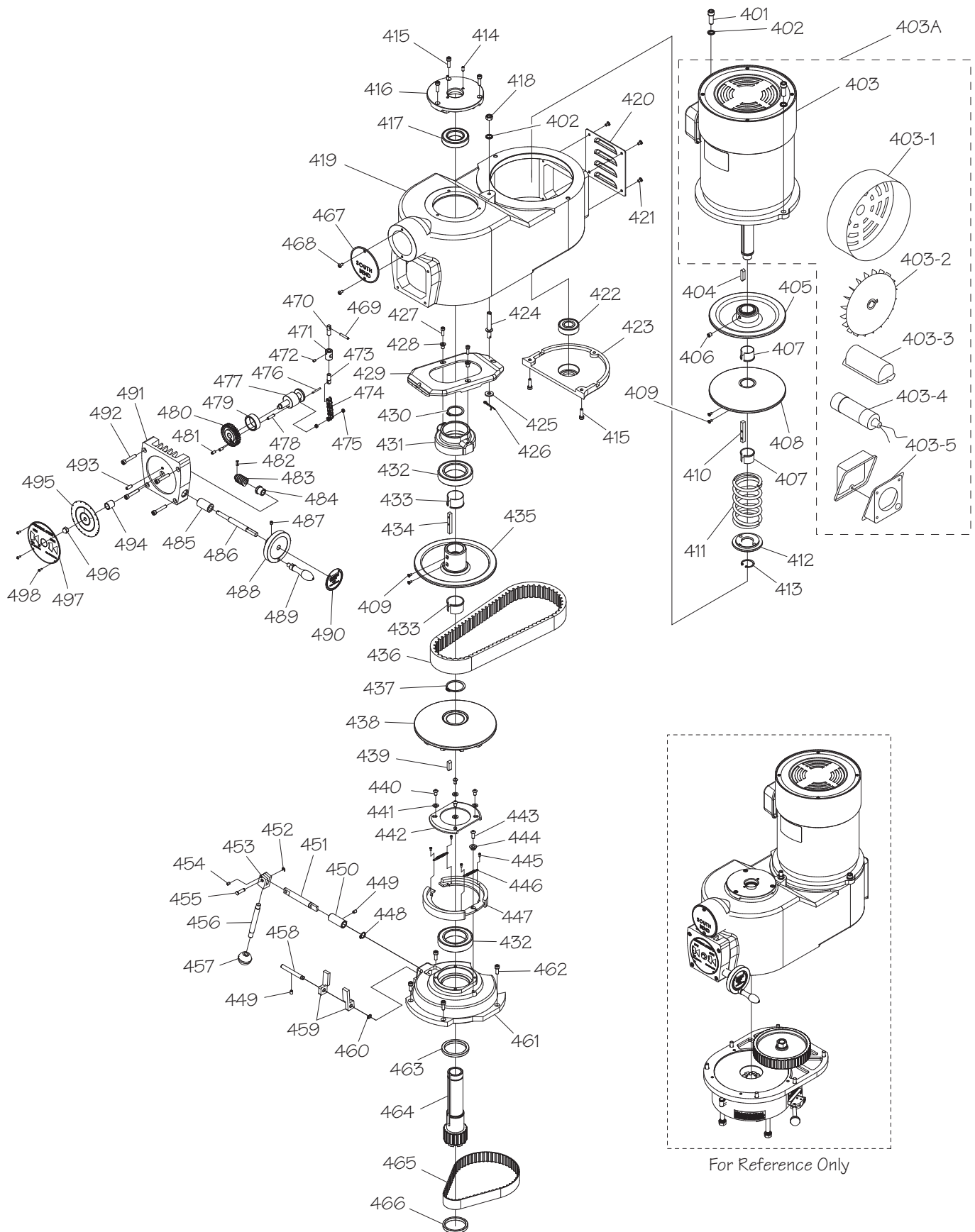

SB1024 Belt Housing Parts List

REF	PART #	DESCRIPTION
401	PCAP14	CAP SCREW 3/8-16 X 1
402	PLW06M	LOCK WASHER 10MM
403A	PSB10240403A	MOTOR ASSEMBLY
403	PSB10240403A	MOTOR 2HP 220V 1PH
403-1	PSB10240403A	MOTOR FAN COVER
403-2	PSB10240403A	MOTOR FAN
403-3	PSB10240403A	CAPACITOR COVER
403-4	PSB10240403A	5 CAPACITOR 600M 125V 2 X 3-1/2
403-5	PSB10240403A	MOTOR JUNCTION BOX
404	PK28M	KEY 7 X 7 X 30
405	PSB10240405	UPPER MOTOR PULLEY PLATE
406	PSS20M	SET SCREW M8-1.25 X 8
407	PSB10240407	MOTOR PULLEY PLASTIC RING
408	PSB10240408	LOWER MOTOR PULLEY PLATE
409	PFH31M	FLAT HD SCR M4-.7 X 8
410	PSB10240410	MOTOR PULLEY ALIGNMENT KEY
411	PSB10240411	MOTOR SHAFT COMPRESSION SPRING
412	PSB10240412	SPRING SEAT
413	PR20M	INT RETAINING RING 28MM
414	PSS05M	SET SCREW M5-.8 X 10
415	PCAP02M	CAP SCREW M6-1 X 20
416	PSB10240416	TOP BEARING COVER
417	P6007W-N	DEEP GROOVE BALL BEARING 6007W NSK
418	PNO8	HEX NUT 3/8-16
419	PSB10240419	BELT HOUSING
420	PSB10240420	REAR VENT COVER
421	PS05M	PHLP HD SCR M5-.8 X 8
422	P6204V-N	DEEP GROOVE BALL BEARING 6204V NSK
423	PSB10240423	MOTOR PULLEY COVER
424	PSB10240424	SPEED CHANGE PLATE PIVOT STUD
425	PWO1M	FLAT WASHER 8MM
426	PSB10240426	COTTER PIN 1/8
427	PCAP24M	CAP SCREW M5-.8 X 16
428	PSB10240428	PIVOT SLEET
429	PSB10240429	SPEED CHANGE PLATE
430	PR12M	EXT RETAINING RING 35MM
431	PSB10240431	SLIDE HOUSING
432	P6010V-N	DEEP GROOVE BALL BEARING 6010V NSK
433	PSB10240433	SPINDLE PULLEY PLASTIC RING
434	PSB10240434	SPINDLE PULLEY ALIGNMENT KEY
435	PSB10240435	UPPER SPINDLE PULLEY PLATE
436	PSB10240436	RIBBED DRIVE BELT 38-12-890
437	PR68M	EXT RETAINING RING 40MM
438	PSB10240438	LOWER SPINDLE PULLEY PLATE
439	PK27M	KEY 7 X 7 X 25
440	PS68M	PHLP HD SCR M6-1 X 10
441	PWO3M	FLAT WASHER 6MM
442	PSB10240442	BRAKE BEARING CAP
443	PS11M	PHLP HD SCR M6-1 X 16
444	PSB10240444	BRAKE SHOE PIVOT SLEEVE
445	PS12M	PHLP HD SCR M3-.5 X 6
446	PSB10240446	BRAKE SHOE SPRING

REF	PART #	DESCRIPTION
447	PSB10240447	BRAKE SHOE SET
448	PR47M	EXT RETAINING RING 13MM
449	PSS03M	SET SCREW M6-1 X 8
450	PSB10240450	BRAKE SHAFT SLEEVE
451	PSB10240451	BRAKE SHAFT
452	PECO2M	E-CLIP 4MM
453	PSB10240453	BRAKE LEVER BRACKET
454	PSS26M	SET SCREW M5-.8 X 6
455	PSB10240455	GROOVED PIN
456	PSB10240456	BRAKE LEVER
457	PSB10240449	ROUND KNOB 3/8-16
458	PSB10240458	BRAKE OPERATING FINGER
459	PSB10240459	BRAKE FINGER PIVOT STUD
460	PR36M	EXT RETAINING RING 7MM
461	PSB10240461	BRAKE SEAT
462	PCAP01M	CAP SCREW M6-1 X 16
463	PSB10240463	SPINDLE PULLEY SPACER
464	PSB10240464	SPINDLE PULLEY HUB
465	PSB10240465	TIMING BELT 225L-100
466	PSB10240466	TIMING PULLEY CLUTCH SLEEVE
467	SB1319	SOUTH BEND NAMEPLATE 90MM
468	PS05M	PHLP HD SCR M5-.8 X 8
469	PRP56M	ROLL PIN 4 X 25
470	PSB10240470	UPPER SPEED CHANGE STUD
471	PSB10240471	SPEED CHANGE STUD SLEEVE
472	PSS45M	SET SCREW M3-.5 X 6
473	PSB10240473	LOWER SPEED CHANGE STUD
474	PSB10240474	SPEED CHANGE CHAIN
475	PNO4M	HEX NUT M4-.7
476	PRP16M	ROLL PIN 3 X 25
477	PSB10240477	SPEED CHANGE CHAIN DRUM
478	PRP03M	ROLL PIN 5 X 20
479	PSB10240479	BUSHING
480	PSB10240480	SPEED CHANGE WORM GEAR
481	PRP35M	ROLL PIN 5 X 10
482	PRP61M	ROLL PIN 3 X 12
483	PSB10240483	WORM
484	PSB10240484	BRONZE SLEEVE BEARING
485	PSB10240485	BUSHING
486	PSB10240486	SPEED CONTROL SHAFT
487	PSS02M	SET SCREW M6-1 X 6
488	PSB10240488	SPEED CHANGE HANDWHEEL
489	PSB10240489	HANDWHEEL HANDLE
490	PSB10240490	SPEED CHANGE WARNING PLATE
491	PSB10240491	SPEED CHANGE HOUSING
492	PCAP48M	CAP SCREW M6-1 X 35
493	PSS11M	SET SCREW M6-1 X 16
494	PSB10240494	BRONZE SLEEVE BEARING
495	PSB10240495	VARIABLE SPEED DIAL
496	PNO2	HEX NUT 5/16-18
497	PSB10240497	VARIABLE SPEED DIAL PLATE
498	PS79M	PHLP HD SCR M3-.5 X 8

SB1025/SB1026 Belt Housing Parts List

REF	PART #	DESCRIPTION
401	P5B10250401	MOTOR 2HP 220V 3PH (SB1025)
401	P5B10260401	MOTOR 2HP 220V 1PH (SB1026)
401-1	P5B10250401-1	MOTOR FAN COVER (SB1025)
401-1	P5B10260401-1	MOTOR FAN COVER (SB1026)
401-2	P5B10250401-2	MOTOR FAN (SB1025)
401-2	P5B10260401-2	MOTOR FAN (SB1026)
401-3	P5B10250401-3	MOTOR JUNCTION BOX (SB1025)
401-3	P5B10260401-3	MOTOR JUNCTION BOX (SB1026)
401-4	P5B10260401-4	CONTACTOR COVER (SB1026)
401-5	P5B10260401-5	5 CAPACITOR 600M 125V (SB1026)
402	PN11	HEX NUT 3/8-24
403	P5B10250403	BELT TENSION ADJUSTMENT LEVER
404	P5B10250407	KNOB 5/16-18
405	P5B10250405	MOTOR PULLEY
406	PK28M	KEY 7 X 7 X 30
407	PW01M	FLAT WASHER 8MM
408	PCAP14M	CAP SCREW M8-1.25 X 20
409	P579M	PHLP HD SCR M3-.5 X 8
410	P5B10250410	CAM RING COVER
411	P5B10250411	CAM RING
412	P5B10250412	CAM RING SCREW M6-1 X 8
413	P5B10250413	MOTOR MOUNTING STUD 1/2-13 X 2-3/16
414	PNO2	HEX NUT 5/16-18
415	P5B10250415	BELT HOUSING
416	P5B10250416	MOTOR MOUNTING WASHER 21 X 13 X 3MM
417	P5B10250417	MOTOR LOCK NUT
418	P5B10250418	MOTOR LOCK LEVER
419	P5B10250419	KNOB 1/4-20

REF	PART #	DESCRIPTION
420	PEC13M	E-CLIP 5MM
421	P5B10250421	BRAKE HANDLE
422	P5526M	SET SCREW M5-.8 X 6
423	P5B10250423	GROOVED PIN
424	P5B10250424	BRAKE HANDLE PIVOT RING
425	SB1319	SOUTH BEND NAMEPLATE 90MM
426	P505M	PHLP HD SCR M5-.8 X 8
427	PRIV001M	FLUTED RIVET 2 X 5MM STEEL
428	P5B10250428	SPINDLE SPEED PLATE
429	P5B10250429	BRAKE STUD
430	P5B10250430	BRAKE RING SCREW
431	P5B10250431	BRAKE SHOE SET
433	P5B10250433	COMPRESSION SPRING
434	P512M	PHLP HD SCR M3-.5 X 6
435	P5B10250435	INNER BEARING RETAINING RING
436	P5B10250436	OUTER BEARING RETAINING RING
437	P6207VV-N	DEEP GROOVE BALL BEARING 6207VV NSK
438	P5B10250438	BEARING SPACER
439	P5B10250439	BEARING SPACER
440	P5B10250440	COMPRESSION SPRING
441	P5545M	SET SCREW M3-.5 X 6
442	P5B10250442	BEARING SEAT
443	P5B10250443	SPINDLE PULLEY
444	PVA33	V-BELT A33
445	P5B10250445	SPINDLE PULLEY SPLINE
446	PK143M	KEY 6 X 6 X 25
447	P5B10250447	TIMING BELT 225L-100
448	P5B10250448	TIMING PULLEY CLUTCH SLEEVE

Ram

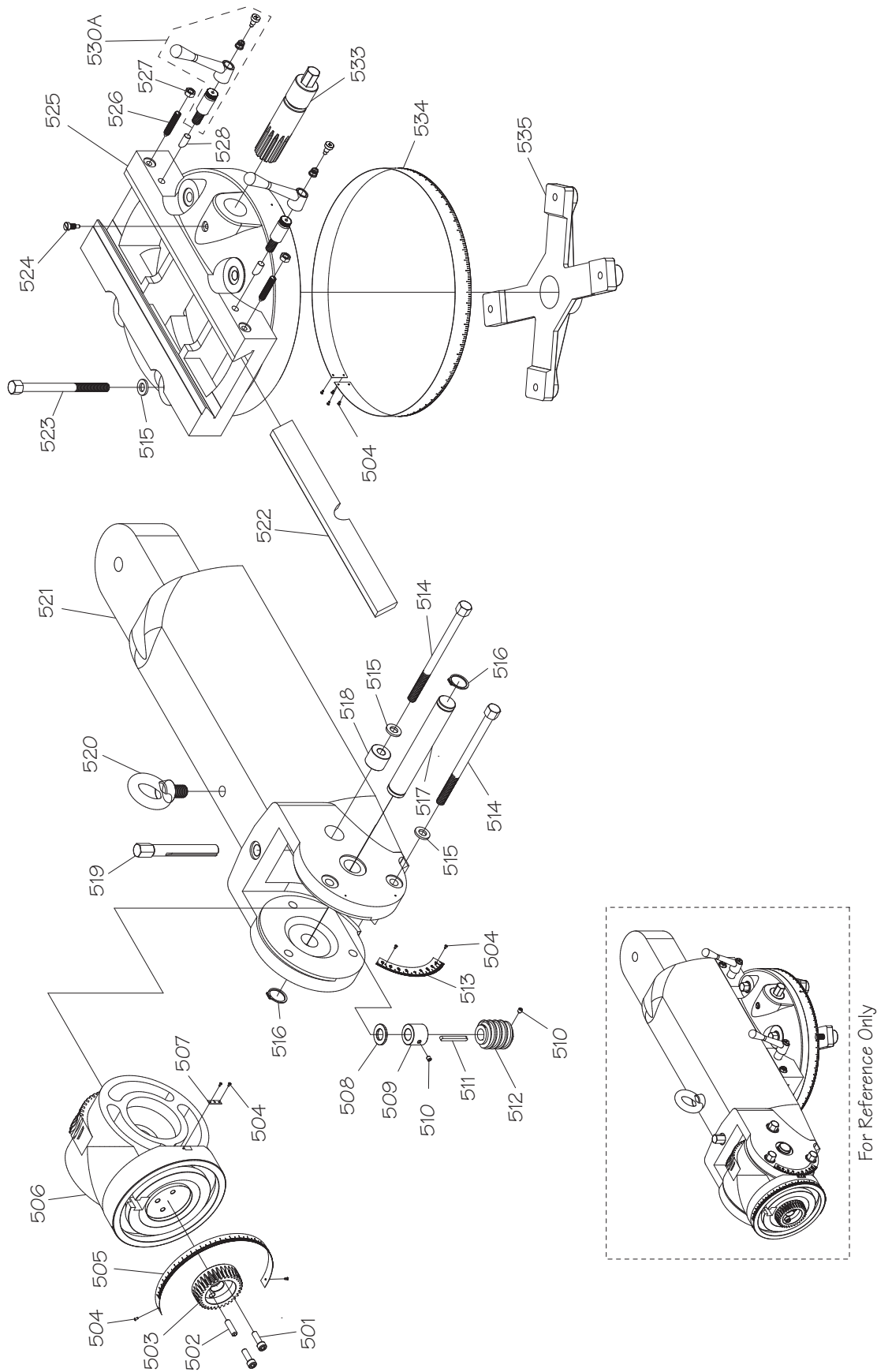

Ram Parts List

REF	PART #	DESCRIPTION
501	PCAP31M	CAP SCREW M8-1.25 X 25
502	PRP90M	ROLL PIN 8 X 30
503	PSB10240503	GEAR 33T
504	PRIV001M	FLUTED RIVET 2 X 5MM STEEL
505	PSB10240505	HEAD ROTATION SCALE
506	PSB10240506	RAM ADAPTER
507	PSB10240507	INDICATOR PLATE
508	PSB10240508	WORM THRUST WASHER
509	PSB10240509	LOCK COLLAR
510	PSS02M	SET SCREW M6-1 X 6
511	PK36M	KEY 5 X 5 X 50
512	PSB10240512	HEAD TILT WORM
513	PSB10240513	HEAD TILT SCALE
514	PSB10240514	TILT LOCK BOLT
515	PW10M	FLAT WASHER 14MM
516	PR19M	EXT RETAINING RING 28MM

REF	PART #	DESCRIPTION
517	PSB10240517	TILT PIVOT STUD
518	PSB10240518	TILT LOCK BOLT BUSHING
519	PSB10240519	HEAD TILT WORM SHAFT
520	PSB10240520	LIFTING EYE BOLT 3/4-10
521	PSB10240521	RAM
522	PSB10240522	RAM GIB
523	PSB10240523	TURRET CLAMP BOLT
524	PSB10240524	RAM PINION SCREW
525	PSB10240525	TURRET
526	PSB10240526	RAM GIB ADJUSTMENT SCREW
527	PNO8	HEX NUT 3/8-16
528	PSB10240528	RAM LOCK PLUNGER
530A	PSB10240530A	LOCK LEVER ASSEMBLY
533	PSB10240533	RAM PINION
534	PSB10240534	RAM ROTATION SCALE
535	PSB10240535	TURRET BRACKET

Column, Knee, & Saddle

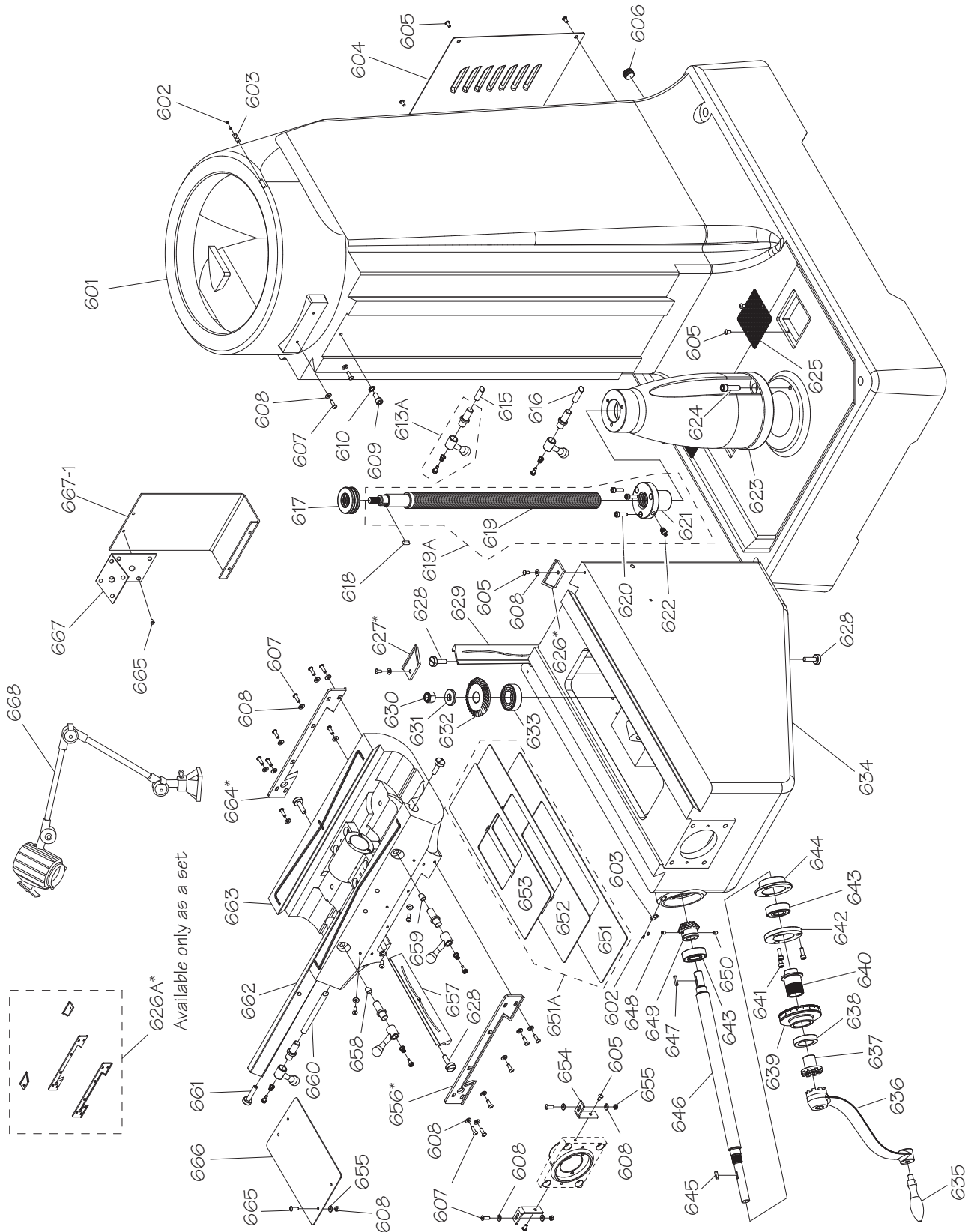

Column, Knee, & Saddle Parts List

REF	PART #	DESCRIPTION
601	PSB10240601	COLUMN
602	PRIV001M	FLUTED RIVET 2 X 5MM STEEL
603	PSB10240603	INDICATOR PLATE
604	PSB10240604	REAR COLUMN COVER
605	PS09M	PHLP HD SCR M5-.8 X 10
606	PSB10240606	PIPE PLUG 1/2 PT
607	PS40M	PHLP HD SCR M5-.8 X 16
608	PW02M	FLAT WASHER 5MM
609	PCAP11M	CAP SCREW M8-1.25 X 16
610	PLW04M	LOCK WASHER 8MM
613A	PSB10240613A	KNEE LOCK LEVER ASSEMBLY
615	PSB10240615	UPPER KNEE LOCK PLUNGER
616	PSB10240616	LOWER KNEE LOCK PLUNGER
617	P51305	THRUST BEARING 51305
618	PK20M	KEY 5 X 5 X 15
619A	PSB10240619A	VERTCAL LEADSCREW W/NUT ASSY
619	PSB10240619A	VERTICAL LEADSCREW INCH
620	PCAP02M	CAP SCREW M6-1 X 20
621	PSB10240619A	VERTICAL LEADSCREW BEVEL NUT INCH
622	PZERK005	GREASE FITTING ST 1/8 PT
623	PSB10240623	VERTICAL LEADSCREW HOUSING
624	PCAP19	CAP SCREW 3/8-16 X 1-1/4
625	PSB10240625	COOLANT SCREEN
626A	PSB10240626A	KNEE/SADDLE WIPER ASSEMBLY
626	PSB10240626A	RIGHT KNEE WIPER
627	PSB10240626A	LEFT KNEE WIPER
628	PSB10240628	GIB SCREW
629	PSB10240629	KNEE GIB
630	PNO1	HEX NUT 1/2-20
631	PSB10240631	BEVEL GEAR FLAT WASHER 1/2
632	PSB10240632	BEVEL GEAR
633	P6205ZZ	BALL BEARING 6205ZZ
634	PSB10240634	KNEE
635	PSB10240635	CRANK HANDLE
636	PSB10240636	VERTICAL CRANK

REF	PART #	DESCRIPTION
637	PSB10240637	CRANK CLUTCH
638	PSB10240638	FRONT DIAL RETAINER
639	PSB10240639	VERTICAL DIAL INCH
640	PSB10240640	REAR DIAL RETAINER
641	PCAP01M	CAP SCREW M6-1 X 16
642	PSB10240642	BEARING RETAINER
643	P6204ZZ	BALL BEARING 6204ZZ
644	PSB10240644	BEARING SEAT
645	PK47M	KEY 4 X 4 X 15
646	PSB10240646	VERTICAL CRANK SHAFT
647	PK48M	KEY 4 X 4 X 20
648	PS502M	SET SCREW M6-1 X 6
649	PSB10240649	BEVEL PINION
650	PS503M	SET SCREW M6-1 X 8
651A	PSB10240651A	CHIP GUARD SET
651	PSB10240651A	OUTER CHIP GUARD
652	PSB10240651A	MIDDLE CHIP GUARD
653	PSB10240651A	INNER CHIP GUARD
654	PSB10240654	WAY COVER SUPPORT
655	PNO6M	HEX NUT M5-.8
656	PSB10240626A	FRONT SADDLE WIPER
657	PSB10240657	SADDLE GIB
658	PSB10240658	LEFT TABLE LOCK PLUNGER
659	PSB10240659	RIGHT TABLE LOCK PLUNGER
660	PSB10240660	SADDLE LOCK PLUNGER
661	PSB10240661	TABLE GIB SCREW
662	PSB10240662	TABLE GIB
663	PSB10240663	SADDLE
664	PSB10240626A	REAR SADDLE WIPER
665	PCAP01M	CAP SCREW M6-1 X 16
666	PSB10240666	FRONT WAY COVER
667	PSB10240667	LAMP MOUNTING BRACKET
667-1	PSB10240667-1	REAR WAY COVER
668	PSB10240668	HALOGEN WORK LAMP ASSY 24V

Table Parts List

REF	PART #	DESCRIPTION
701	PN01	HEX NUT 1/2-20
702	PSB10240702	HANDLE
703	PSB10240703	CROSS FEED BALL HANDLE
704A	PSB10240704A	DIAL HOLDER ASSEMBLY
704	PSB10240704A	OUTER DIAL HOLDER
705	PSB10240705	TABLE DIAL INCH
706	PSB10240704A	INNER DIAL HOLDER
707	PCAP01M	CAP SCREW M6-1 X 16
708	PSB10240708	BEARING RETAINER RING
709	P6204ZZ	BALL BEARING 6204ZZ
710	PRP05M	ROLL PIN 5 X 30
711	PCAP14	CAP SCREW 3/8-16 X 1
712	PSB10240712	CROSS FEED BEARING BRACKET
713	PK92M	KEY 3 X 3 X 25
714A	PSB10240714A	CROSS FEED LEADSCREW W/NUTS ASSY
714	PSB10240714A	CROSS FEED LEADSCREW
715	PSS01	SET SCREW 5/16-18 X 1
716	PW07	FLAT WASHER 5/16
717	PSB10240717	TRAVEL STOP
718	PSB10240718	TRAVEL STOP SHAFT
719	PSB10240719	COMPRESSION SPRING
720	PSB10240720	TRAVEL STOP T-NUT
721	PSB10240721	TRAVEL STOP FLAT WASHER 8MM
722	PR39M	EXT RETAINING RING 8MM

REF	PART #	DESCRIPTION
723A	PSB10240723A	LONGITUDINAL BALL HANDLE ASSY
723	PSB10240723A	LONGITUDINAL BALL HANDLE
724	PSS08M	SET SCREW M4-.7 X 5
725	PSB10240723A	TABLE BALL HANDLE CLUTCH ASSY
729	PSB10240729	TABLE BEARING BRACKET
730	PSB10240730	RUBBER TABLE T-SLOT PLUG
731	PSB10240606	PIPE PLUG 1/2 PT
732	PSB10240732	LONGITUDINAL LEADSCREW INCH
733	PCAP06M	CAP SCREW M6-1 X 25
734	PW03M	FLAT WASHER 6MM
735	PSB10240714A	FRONT CROSS LEADSCREW NUT
736	PSB10240736	LEADSCREW NUT BRACKET
737	PSB10240737	LEFT LONGITUDINAL LEADSCREW NUT
738	PSB10240714A	REAR CROSS FEED LEADSCREW NUT
739	PSB10240739	RIGHT LONGITUDINAL LEADSCREW NUT
740	PSB10240740	BEARING RETAINING RING
741	PSB10240741	POWER FEED ASSEMBLY
742	PSB10240742	BEVEL GEAR BUSHING
743	PSB10240743	POWER FEED BEVEL GEAR
744	PSB10240744	BEVEL GEAR NUT
745	PSB10240745	TABLE 9 X 42"
746	PSB10240746	LONGITUDINAL LIMIT SWITCH ASSEMBLY
747	PW02	FLAT WASHER 3/8
748	PCAP100	CAP SCREW 3/8-16 X 1/2

One-Shot Oiler

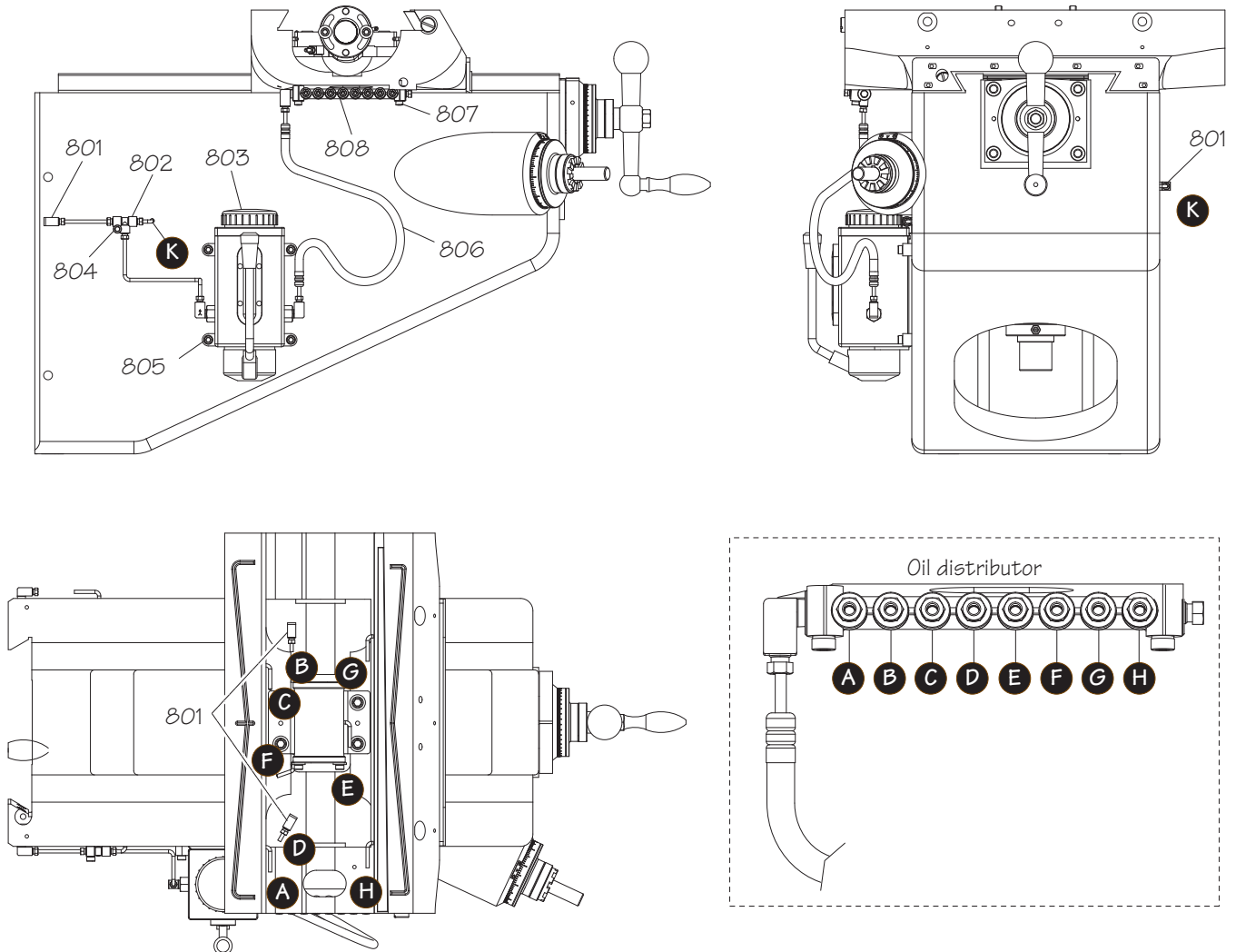

REF	PART #	DESCRIPTION
801	PSB10240801	ELBOW JOINT M4 X 1/8 PT
802	PSB10240802	T-JOINT
803	PSB10240803	ONE SHOT OILER ASSEMBLY
804	PCAP02M	CAP SCREW M6-1 X 20

REF	PART #	DESCRIPTION
805	PCAP01M	CAP SCREW M6-1 X 16
806	PSB10240806	FLEXIBLE STEEL TUBE 4 X 500MM
807	PCAP38M	CAP SCREW M5-.8 X 25
808	PSB10240808	OIL DISTRIBUTOR 8-PORT

SB1024/SB1026 Electrical Box & Control Panel

Electrical Box

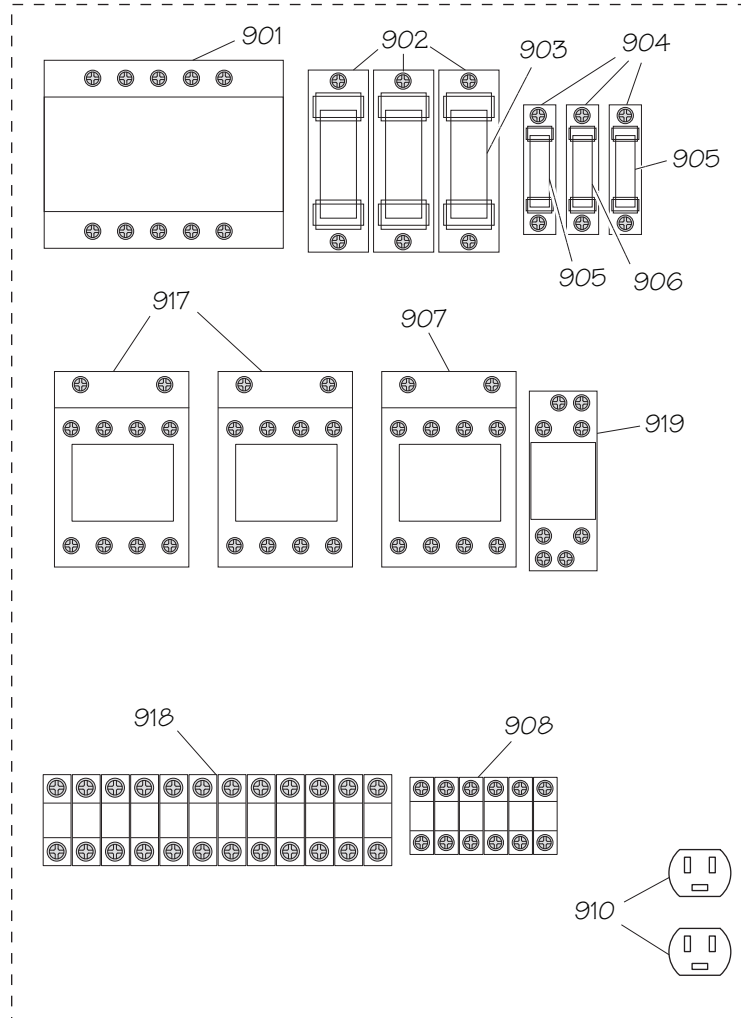

Control Panel

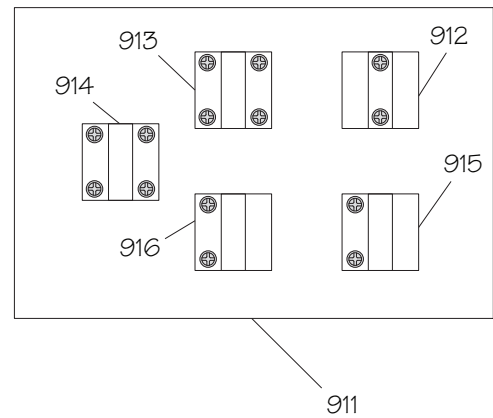

REF	PART #	DESCRIPTION
901	PSB10240901	TRANSFORMER 24-440V YJ A009-0383
902	PSB10240902	FUSE HOLDER 30A
903	PSB10240903	FUSE 30A
904	PSB10240904	FUSE HOLDER 2-5A
905	PSB10240905	FUSE 5A
906	PSB10240906	FUSE 2A
907	PSB10240907	CONTACTOR AB C09-400 220V
908	PSB10240908	TERMINAL BAR 6-POST
910	PSB10240910	POWER RECEPTACLE 100V

REF	PART #	DESCRIPTION
911	PSB10240911	CONTROL PANEL
912	PSB10240912	POWER INDICATOR ASSEMBLY
913	PSB10240913	SPINDLE START BUTTON ASSEMBLY
914	PSB10240914	SPINDLE DIRECTION SWITCH ASSEMBLY
915	PSB10240915	EMERGENCY STOP BUTTON ASSEMBLY
916	PSB10240916	SPINDLE STOP BUTTON ASSEMBLY
917	PSB10240917	CONTACTOR AB C16-01 220V
918	PSB10240918	TERMINAL BAR 12-POST
919	PSB10240919	RELAY OMERON MY2J 24V

SB1025 Electrical Box & Control Panel

Electrical Box

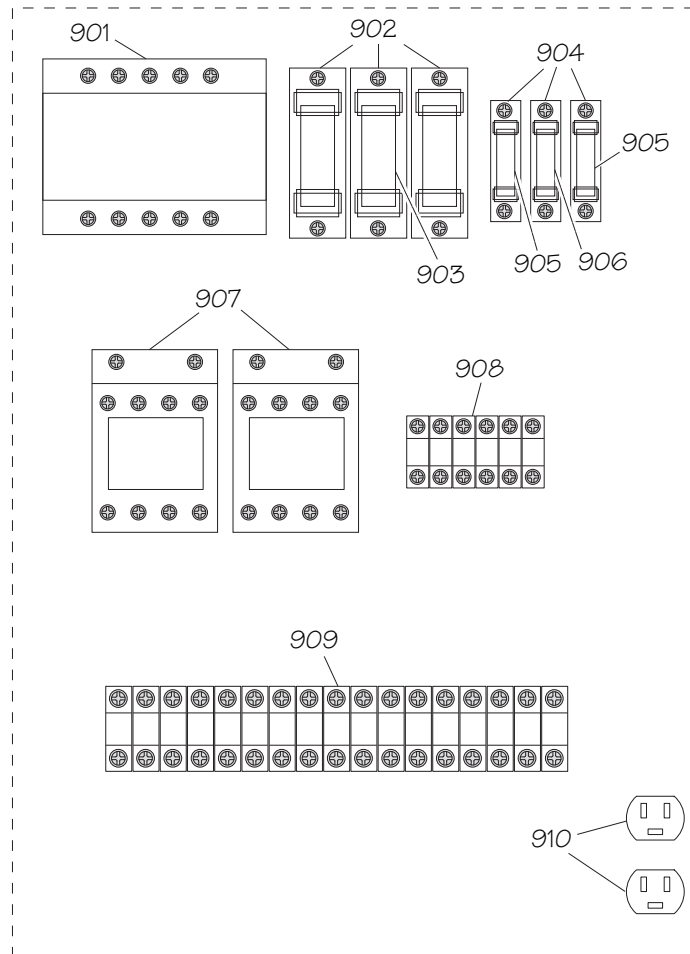

Control Panel

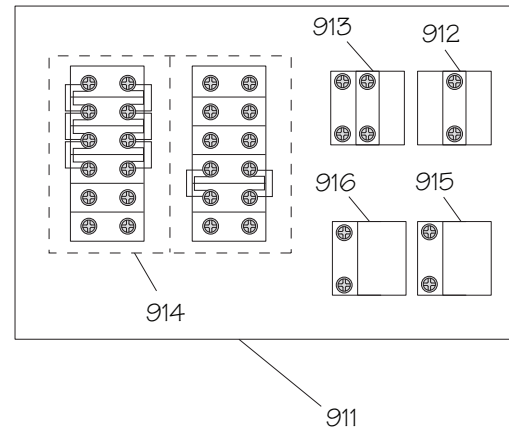

REF	PART #	DESCRIPTION
901	PSB10240901	TRANSFORMER 24-440V YJ A009-0383
902	PSB10240902	FUSE HOLDER 30A
903	PSB10240903	FUSE 30A
904	PSB10240904	FUSE HOLDER 2-5A
905	PSB10240905	FUSE 5A
906	PSB10240906	FUSE 2A
907	PSB10240907	CONTACTOR AB C09-400 220V
908	PSB10240908	TERMINAL BAR 6-POST

REF	PART #	DESCRIPTION
909	PSB10250909	TERMINAL BAR 17-POST
910	PSB10240910	POWER RECEPTACLE 100V
911	PSB10250911	CONTROL PANEL
912	PSB10240912	POWER INDICATOR ASSEMBLY
913	PSB10240913	SPINDLE START BUTTON ASSEMBLY
914	PSB10250914	SPINDLE DIRECTION SWITCH ASSEMBLY
915	PSB10240915	EMERGENCY STOP BUTTON ASSEMBLY
916	PSB10240916	SPINDLE STOP BUTTON ASSEMBLY

Accessories

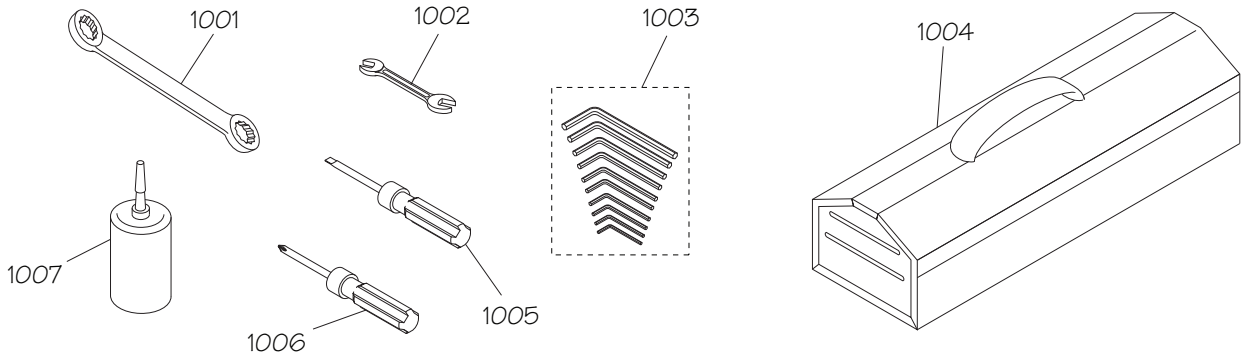

REF	PART #	DESCRIPTION
1001	PWR1921C	CLOSED END WRENCH 19/21MM
1002	PWR1214	WRENCH 12/14MM
1003	PAW1510M	HEX WRENCH SET 10PC 1.5-10 MM
1004	PSB10241004	TOOL BOX

REF	PART #	DESCRIPTION
1005	PSDF2	FLAT SCREWDRIVER #2
1006	PSDP2	PHILLIPS SCREWDRIVER #2
1007	PSB10241007	OIL BOTTLE

SB1024 Head Machine Labels

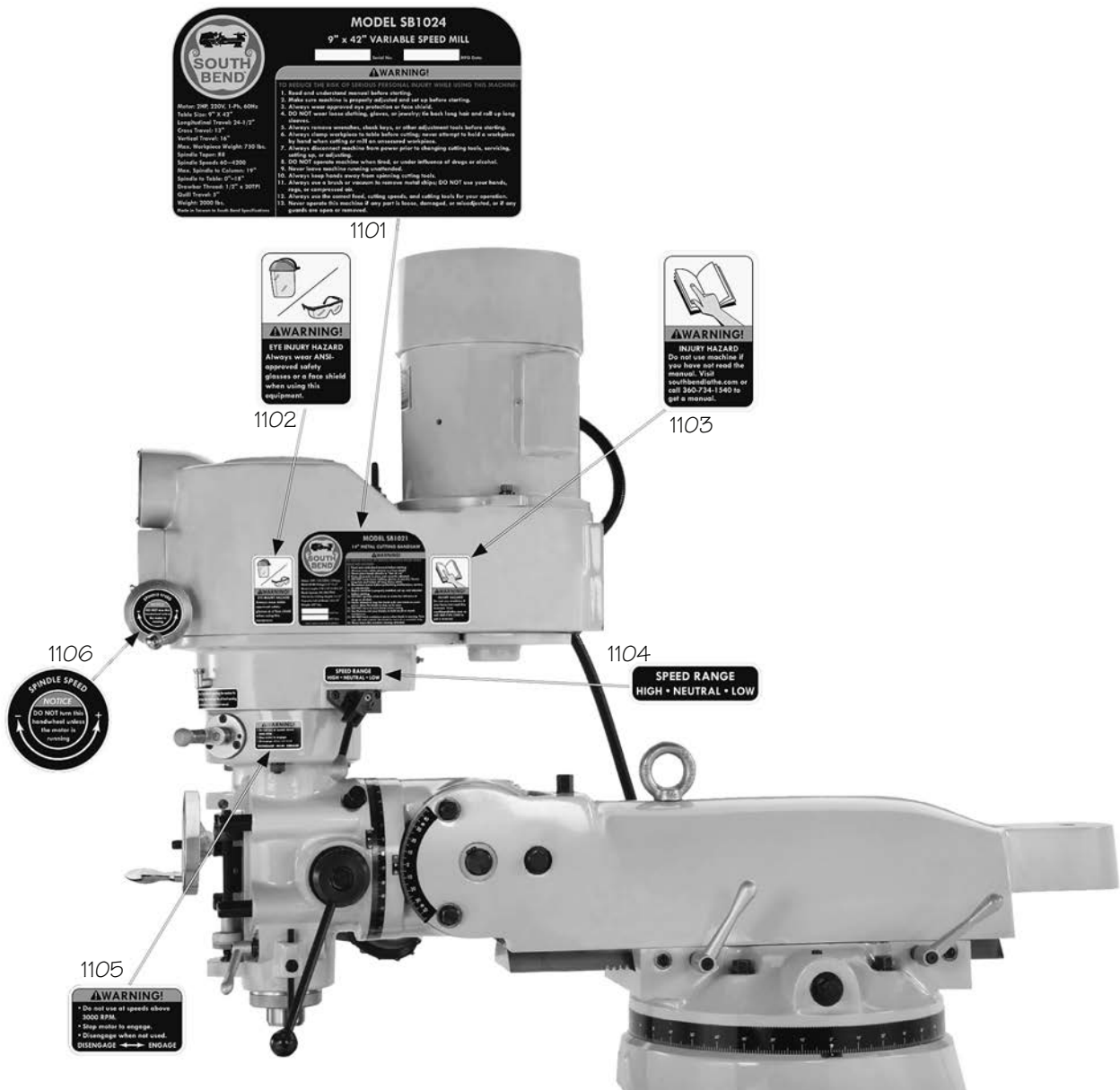

REF	PART #	DESCRIPTION
1101	PSB10241101	MACHINE ID LABEL
1102	PSBLABELO7YL	EYE INJURY HAZARD LABEL
1103	PSBLABELO1VL	READ MANUAL LABEL

REF	PART #	DESCRIPTION
1104	PSB10241104	SPEED RANGE LABEL
1105	PSB10241105	DOWNFEED WARNING LABEL
1106	PSB10241106	VARIABLE SPINDLE SPEED LABEL

⚠ WARNING

The safety labels provided with your machine are used to make the operator aware of the machine hazards and ways to prevent injury. The owner of this machine **MUST** maintain the original location and readability of these safety labels. If any label is removed or becomes unreadable, **REPLACE** that label before using the machine again. Contact South Bend Lathe Co. at (360) 734-1540 or www.southbendlathe.com to order new labels.

SB1024 Main Machine Labels

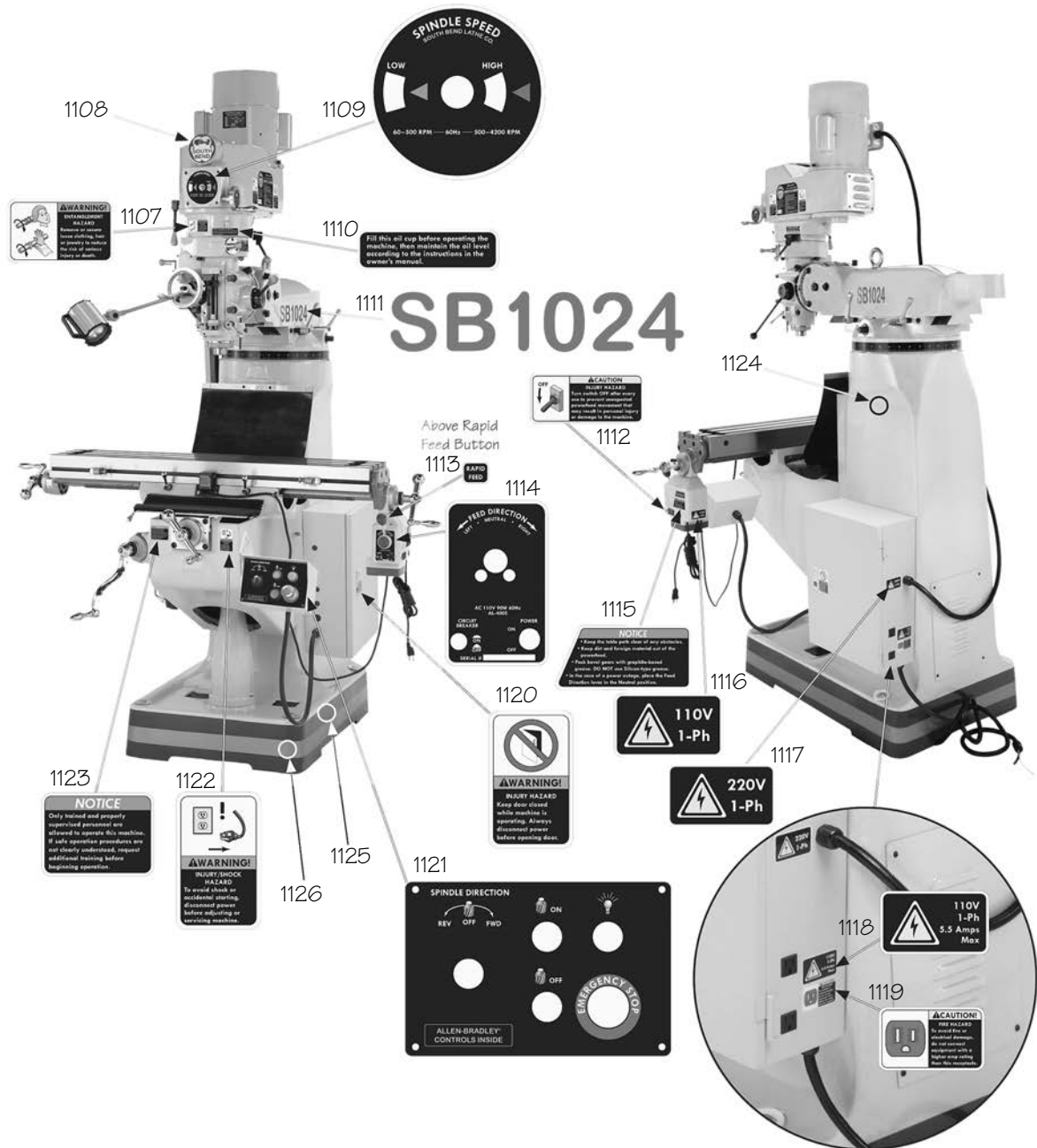

REF	PART #	DESCRIPTION
1107	PSBLABEL08VL	ENTANGLEMENT HAZARD LABEL
1108	SB1319	SOUTH BEND NAMEPLATE 90MM
1109	PSB10241109	SPINDLE SPEED DISPLAY LABEL
1110	PSB10241110	HEAD LUBRICATION LABEL
1111	PSB10241111	MODEL NUMBER LABEL
1112	PSB10241112	POWER FEED WARNING LABEL
1113	PSB10241113	POWER FEED RAPID FEED LABEL
1114	PSB10241114	POWER FEED CONTROL LABEL
1115	PSB10241115	POWER FEED NOTICE LABEL
1116	PSB10241116	110V 1PH LABEL

REF	PART #	DESCRIPTION
1117	PSB10241117	220V 1PH LABEL
1118	PSB10241118	110V 1PH 5.5A LABEL
1119	PSB10241119	PLUG RECEPTACLE FIRE HAZARD LABEL
1120	PSB10241120	ELECTRICAL BOX WARNING LABEL
1121	PSB10241121	CONTROL PANEL LABEL
1122	PSBLABEL02VL	DISCONNECT POWER LABEL
1123	PSB10241123	QUALIFIED PERSONNEL NOTICE LABEL
1124	PSBPAINTO1	SB GRAY TOUCH-UP PAINT
1125	PSBPAINTO2	SB LIGHT BLUE TOUCH-UP PAINT
1126	PSBPAINTO3	SB DARK BLUE TOUCH-UP PAINT

SB1025/SB1026 Machine Labels

SB1025 SB1026

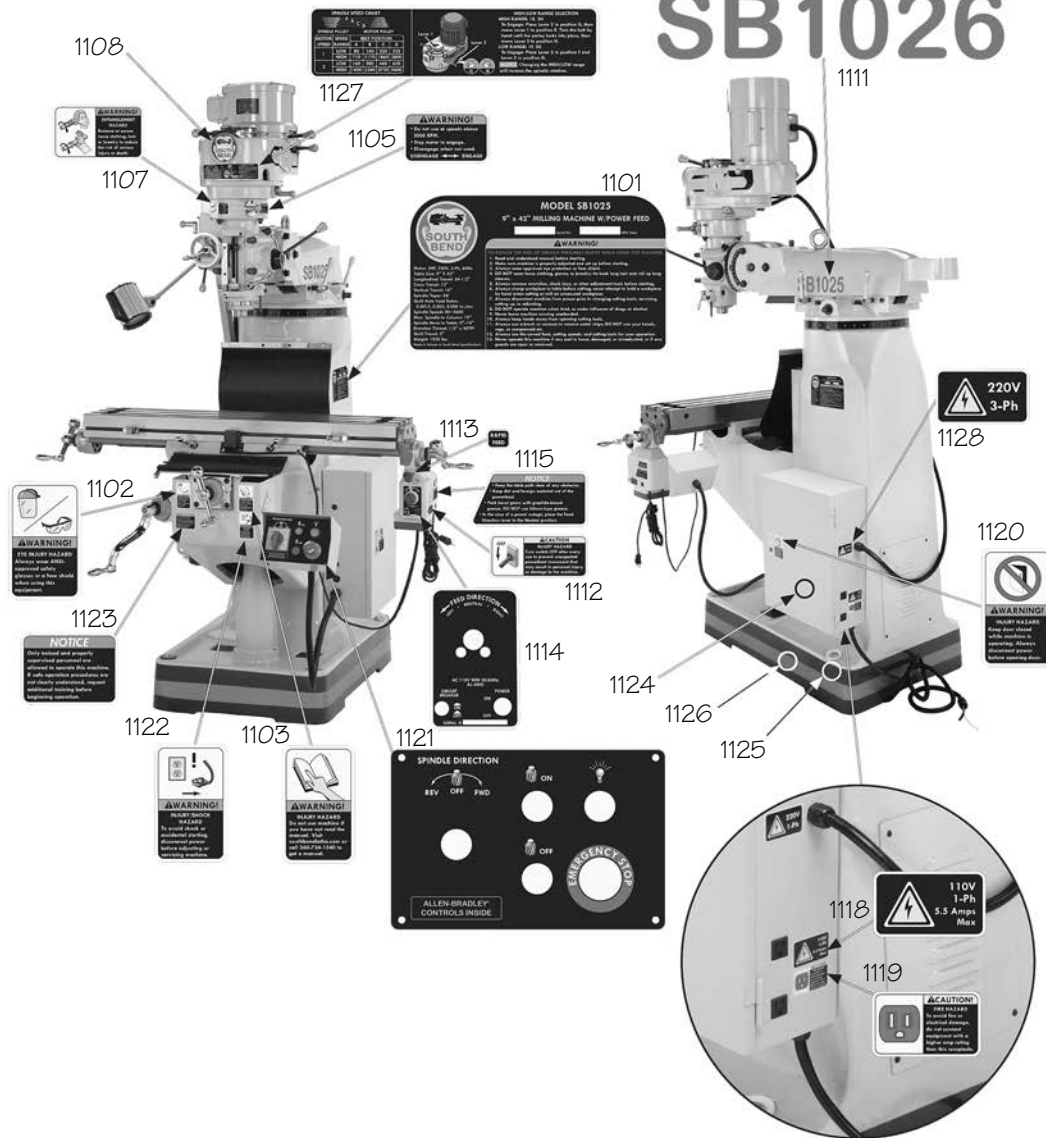

REF	PART #	DESCRIPTION
1101	PSB10251101	MACHINE ID LABEL (SB1025)
1101	PSB10261101	MACHINE ID LABEL (SB1026)
1102	PSBLABEL07VL	EYE INJURY HAZARD LABEL
1103	PSBLABEL01VL	READ MANUAL LABEL
1105	PSB10241105	DOWNFEED WARNING LABEL
1107	PSBLABEL08VL	ENTANGLEMENT HAZARD LABEL
1108	SB1319	SOUTH BEND NAMEPLATE 90MM
1111	PSB10251111	MODEL NUMBER LABEL (SB1025)
1111	PSB10261111	MODEL NUMBER LABEL (SB1026)
1112	PSB10241112	POWER FEED WARNING LABEL
1113	PSB10241113	POWER FEED RAPID FEED LABEL
1114	PSB10241114	POWER FEED CONTROL LABEL

REF	PART #	DESCRIPTION
1115	PSB10241115	POWER FEED NOTICE LABEL
1118	PSB10241118	110V 1PH 5.5A LABEL
1119	PSB10241119	PLUG RECEPTACLE FIRE HAZARD LABEL
1120	PSB10241120	ELECTRICAL BOX WARNING LABEL
1121	PSB10241121	CONTROL PANEL LABEL
1122	PSBLABEL02VL	DISCONNECT POWER LABEL
1123	PSB10241123	QUALIFIED PERSONNEL NOTICE LABEL
1124	PSBPAINTO1	SB GRAY TOUCH-UP PAINT
1125	PSBPAINTO2	SB LIGHT BLUE TOUCH-UP PAINT
1126	PSBPAINTO3	SB DARK BLUE TOUCH-UP PAINT
1127	PSB10251127	SPINDLE SPEED CHART LABEL
1128	PSB10251128	220V 3PH LABEL

WARRANTY

This quality product is warranted by South Bend Lathe Company to the original buyer for one year from the date of purchase. This warranty does not apply to consumable parts, or defects due to any kind of misuse, abuse, negligence, accidents, repairs, alterations or lack of maintenance. We do not reimburse for third party repairs. In no event shall we be liable for death, injuries to persons or property, or for incidental, contingent, special or consequential damages arising from the use of our products.

We do not warrant or represent that this machine complies with the provisions of any law, act, code, regulation, or standard of any domestic or foreign government, industry, or authority. In no event shall South Bend's liability under this warranty exceed the original purchase price paid for this machine. Any legal actions brought against South Bend Lathe Company shall be tried in the State of Washington, County of Whatcom.

This is the sole written warranty for this machine. Any and all warranties that may be implied by law, including any merchantability or fitness, for any purpose, are hereby limited to the duration of this warranty. To take advantage of this warranty, contact us by mail or phone to give us the details of the problem you are having.

Thank you for your business and continued support.



southbendlathe.com

