



# Instruction Sheet

## Model SB1314

### High Precision 6" Lathe Chuck



## ⚠️ WARNING

Chucks are heavy! Get assistance when installing or removing the chuck from the lathe. Wear heavy duty leather boots for foot and toe protection, and keep hands and fingers away from all pinch points. Ignoring this warning can lead to a severe crushing injury or finger amputation!



## Specifications

- OD Clamping Range ... 0.32"-6.30" (8-160mm)
- ID Clamping Range .. 2.17"-5.90" (55-150mm)
- Outer Diameter ..... 6.57" (167mm)
- Maximum Chuck Key Torque ..... 65 ft/lbs\*
- Maximum Jaw Gripping Force ..... 6744 lbs\*
- Maximum Speed ..... 4000 RPM\*\*
- Two-Piece Hardened Steel Jaws ..... Yes
- Plain Back Mounting ..... Yes
- Jaw Mounting Cap Screw Torque ..... 29 ft/lbs
- Grease Fitting Lubricated ..... Yes
- Steel Construction ..... Yes
- Chuck Weight..... 22 lbs
- Origin..... Taiwan

\* Maximum handle torque and gripping force is achieved at full jaw and scroll gear engagement only.

\*\* The maximum speed above is ONLY possible when the chuck jaws and the workpiece are in complete rotational symmetry, and when the workpiece is within safe weight limits for the lathe and chuck.

**If you need help with your new item, contact us at: (360) 734-1540 • FAX: (360) 676-1075**

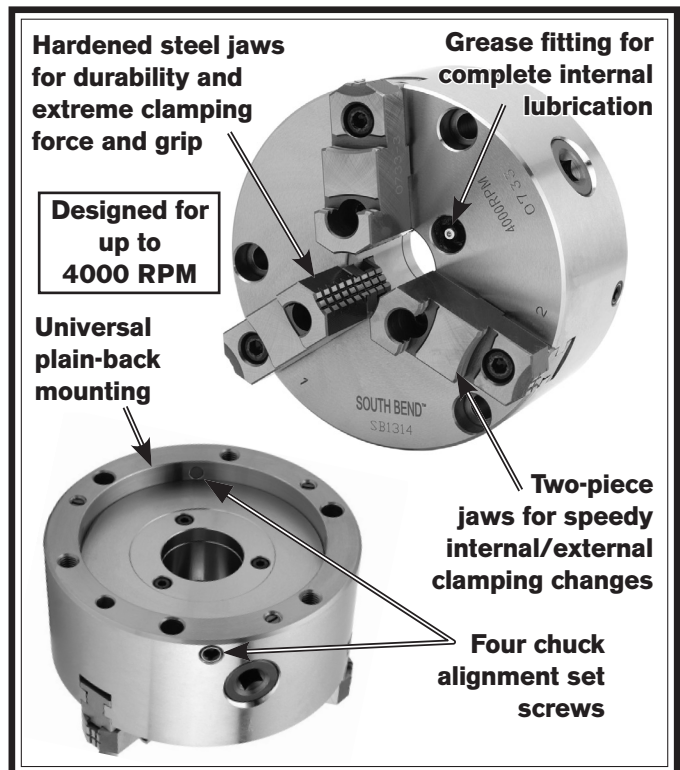

Figure 1. Features.

## Installation

1. DISCONNECT LATHE FROM POWER!
2. Mount the back plate on the spindle.
3. Accurately measure the inside of the back relief bore on the chuck. This dimension is critical and should be  $\pm 0.001$ ".
4. Face and true the diameter of the back plate. Make passes across the face until its entire surface has been cut.
5. Turn a shoulder that is 0.015" smaller in diameter than that of the chuck relief bore. The shoulder height must also be tall enough so when the chuck is mounted and is being aligned, the chuck alignment screws have a surface to jack against.

6. Remove the back plate from the lathe and place it on a workbench.
7. Set the chuck on the back plate, and roughly align the chuck using the alignment set screws.
8. Use a transfer punch to mark the back plate. If a transfer punch is not available, a drill bit of the same size as the mounting holes in the chuck can be used. Lightly tap on the bit, rotate it 90° and tap it again.
9. Center punch the marks. Drill and tap the holes for M10-1.5 threads.
10. Clean and stone all mating surfaces until they are perfectly clean and no burrs exist.
11. Install the chuck and snug the M10-1.5 cap screws in an alternating pattern until you reach a final torque of 53.5 ft/lbs. Alternating the tightening process avoids chuck warpage. If you are installing the chuck by threading the M10-1.5 hex bolts into the chuck from the back side of the mounting plate, repeat **Step 11** on these bolts, and torque the bolts to 30 ft/lbs.
12. Using a 6mm hex wrench, lightly snug all four chuck alignment set screws.
13. Clamp a 1" diameter test blank into the chuck, install a test indicator. Rotate the chuck by hand and measure the chuck concentricity.
14. Based on your readings, adjust the alignment set screws to bring the chuck into final alignment. The typical alignment repeatability for the same diameter workpiece when swapping will be 0.0005". For maximum accuracy, clamp your workpiece in the chuck and realign by tightening or loosening the set screws. If all the set screws are tight, correction of alignment can also be done by loosening one or more set screws.

**Note:** If the chuck must move 0.001" or less to bring the workpiece into alignment, it is not necessary to loosen the chuck mounting bolts before using the adjustment set screws.

## Operation and Safety

- **Chuck Key Safety:** A chuck key left in the chuck can become a dangerous projectile when the spindle is started. Always remove the chuck key after using it. Develop a habit of not taking your hand off of a chuck key unless it is away from the machine.
- **Disconnect Power:** Disconnect the lathe from power before installing and removing the chuck or doing any maintenance or adjustments. Accidental lathe startup can cause severe injury or death.
- **Secure Clamping:** A thrown workpiece may cause severe injury or even death. When swapping the chuck jaw positions, use a torque wrench to re-torque the M8-1.25 jaw mounting cap screws to 29 ft/lbs. When clamping a workpiece, maximum gripping force is attained at full jaw and scroll gear engagement. If the jaw and scroll gear are partially engaged, clamping force is reduced.
- **Chuck Speed Rating:** Exceeding the maximum rated speed indicated on the chuck, or using excessive spindle speeds with an unbalanced workpiece, can cause the workpiece to be thrown from the chuck causing a severe impact injury or even death. Always use the appropriate spindle speed for the job.
- **Large Chucks:** Large chucks are very heavy and difficult to grasp, which can lead to crushed fingers or hands if mishandled. Get assistance when installing or removing large chucks to reduce this risk. Protect your hands and the precision ground ways by using a chuck cradle or piece of plywood over the ways of the lathe when servicing chucks.
- **Safe Clearances:** Often chuck jaws will protrude past the diameter of the chuck and can contact a coolant nozzle, tooling, tool post, or nearby components. Before starting the spindle, make sure the workpiece and the chuck jaws have adequate clearance by rotating the spindle through its entire range of motion by hand.

## Care & Maintenance

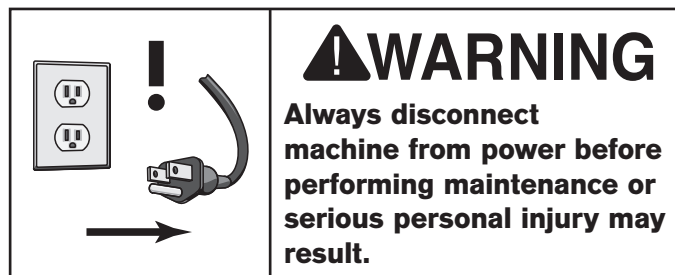

For optimum performance from your chuck, follow the maintenance schedule below, and never hammer on the chuck, jaws, or a workpiece clamped in the chuck. Never subject the chuck to abrasives, flame, or water.

### Daily:

- Check/correct loose mounting bolts.
- Use a vacuum, rag, or brush to clean the chuck after use. Never use air pressure to clean chips away from a chuck.
- Wipe the chuck down with a thin coat of way oil to prevent surface rust.
- Grease the chuck fitting with one to two pumps of NLGI #2 grease.

If the chuck ever becomes stiff to operate, it may have been contaminated with metal chips or abrasives from neglect or poor service practices. The chuck must be disassembled, cleaned, and re-lubricated.

### To disassemble the chuck for a full cleaning and lubrication service:

1. DISCONNECT LATHE FROM POWER!
2. Mark the chuck and the mounting plate where they mate to ensure that when reassembled both halves line up. Next, unbolt the chuck and separate both halves.
3. Insert and rotate the chuck key counterclockwise until the scroll-gear has released all three jaws from the chuck.
4. Using a 4mm and 6mm hex wrench, a #1 standard screwdriver, and a ratchet with a 7mm socket, start at #1 and disassemble the chuck in the sequence shown in **Figure 2**.

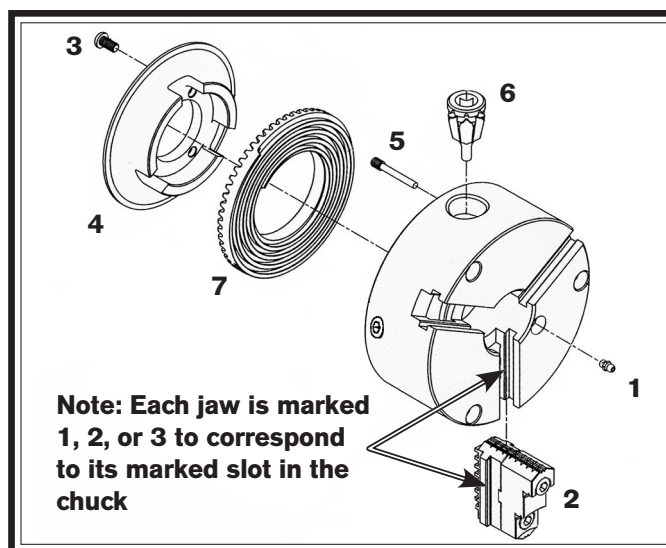

**Figure 2. Chuck sequence of disassembly.**

5. Using mineral spirits, clean and dry all components. Inspect all bores, teeth, pins, and mating surfaces for wear, burrs, galling, rust, or cracks.
6. Without changing the dimension of any part, use a wire brush, emery cloth, or dressing stones, to remove all rust, burrs, and any high spots caused by galling.
7. Coat all parts with any automotive NLGI #2 grease, and carefully reassemble the chuck in the reverse order shown in **Figure 2**.
8. Rotate the chuck key clockwise until you see the tip of the scroll-gear lead thread just begin to enter jaw guide #1.
9. Insert jaw #1 into jaw guide #1, and hold the jaw against the scroll-gear.
10. Rotate the chuck key clockwise one turn to engage the tip of the scroll-gear lead thread into the jaw. Pull the jaw; it should be locked into the jaw guide.
11. Install the other jaws in the same manner, and install a new grease fitting if ball or nipple leak grease.
12. Line up the timing mark on the chuck and the mounting plate, and fasten both halves by tightening and torquing the fasteners as outlined in **Step 11 in Installation**.

## Troubleshooting

If you need replacement parts, or if you are unsure how to do any of the solutions given here, feel free to call us at (360) 734-1540.

Symptom	Possible Cause	Possible Solution
The chuck has hard spots or binds completely.	<ol style="list-style-type: none"> <li>1. Jaw is in wrong position.</li> <li>2. Lack of lubrication, rust, burrs, or metal shavings inside of chuck.</li> <li>3. Broken tooth on the pinion or the scroll gear.</li> </ol>	<ol style="list-style-type: none"> <li>1. Reinstall jaws in correct order and position on scroll gear.</li> <li>2. Disassemble, de-burr, clean, and lubricate chuck.</li> <li>3. Disassemble, replace broken parts if possible, and reassemble chuck.</li> </ol>
The workpiece slips in the jaws.	<ol style="list-style-type: none"> <li>1. Incorrect jaw or workpiece clamping position.</li> <li>2. Insufficient pinion and scroll gear torque.</li> <li>3. Cutting overload.</li> <li>4. Chuck is binding before full clamping is achieved.</li> </ol>	<ol style="list-style-type: none"> <li>1. Reposition jaws and workpiece for maximum scroll gear and jaw engagement is achieved.</li> <li>2. Tighten chuck key to 65 ft/lbs.</li> <li>3. Reduce cutting depth or feed rate.</li> <li>4. Disassemble and service/rebuild chuck.</li> </ol>
Clamping accuracy is poor.	<ol style="list-style-type: none"> <li>1. Workpiece is improperly clamped or jaw is loose or incorrectly seated.</li> <li>2. Chuck loose, mounting is off center, or it is improperly seated.</li> </ol>	<ol style="list-style-type: none"> <li>1. Remove jaws, clean, de-burr, and re-install with jaw mounting caps crews torqued to 29 ft/lbs.</li> <li>2. Remove chuck, clean and de-burr mounting, and re-install, or machine a new mounting plate.</li> </ol>

## Parts Diagram

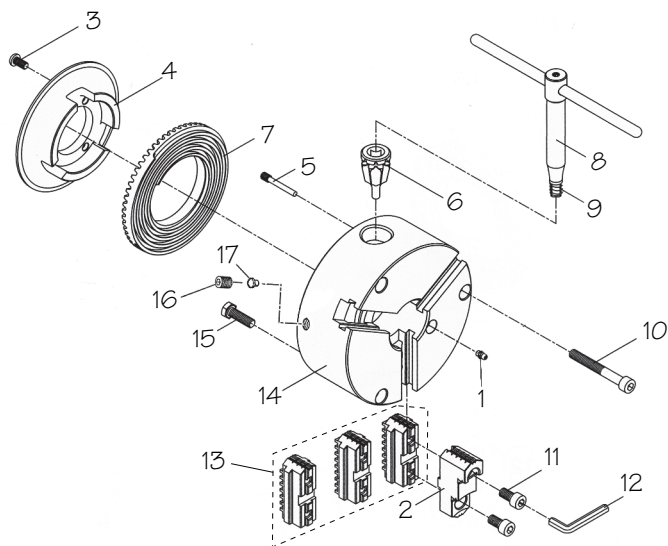

## Parts List

REF	PART #	DESCRIPTION
1	PSB1314001	GREASE FITTING
2	PSB1314002	TOP JAW
3	PCAP33M	CAP SCREW M5-.8 X 12
4	PSB1314004	BACK COVER
5	PSB1314005	LOCK PIN
6	PSB1314006	PINION
7	PSB1314007	SCROLL GEAR
8	PSB1314008	CHUCK KEY W/SPRING
9	PSB1314009	COMPRESSION SPRING
10	PCAP171M	CAP SCREW M10-1.5 X 80 BLK C12.9
11	PCAP172M	CAP SCREW M8-1.25 X 20 BLK C12.9
12	PAW08M	HEX WRENCH 8MM
13	PSB1314013	BOTTOM JAW SET OF 3
14	PSB1314014	CHUCK BODY
15	PB174M	HEX BOLT M10-1.5 X 35 BLK C12.9
16	PSS108M	SET SCREW M12-1.75 X 10
17	PSB1314017	FLANGE PIN

**Please Note:** We included this breakdown for service purposes only. Since many of the parts shown are machined to each individual chuck, they are not available as replacement items.

Copyright © March, 2010 By South Bend Lathe Co. Revised February, 2011 (CR)

**WARNING:** No portion of this manual may be reproduced in any shape or form without the written approval of South Bend Lathe Co.

#CR12663 Printed in Taiwan.

[www.southbendlathe.com](http://www.southbendlathe.com)