



MODEL T10537 7-PIECE GLASS/GRANITE DRILLING SET INSTRUCTIONS

For questions or help with this product contact Tech Support at (570) 546-9663 or techsupport@grizzly.com

Introduction

This set features 6 diamond bits that cut through mirror, non-tempered glass, ceramics, porcelain, limestone, marble, and granite. DO NOT drill tempered glass! Tempered glass will shatter.

These bits can be used with a handheld drill or drill press. Use a drill press whenever possible for greater control and precision (see **Figure 1**).

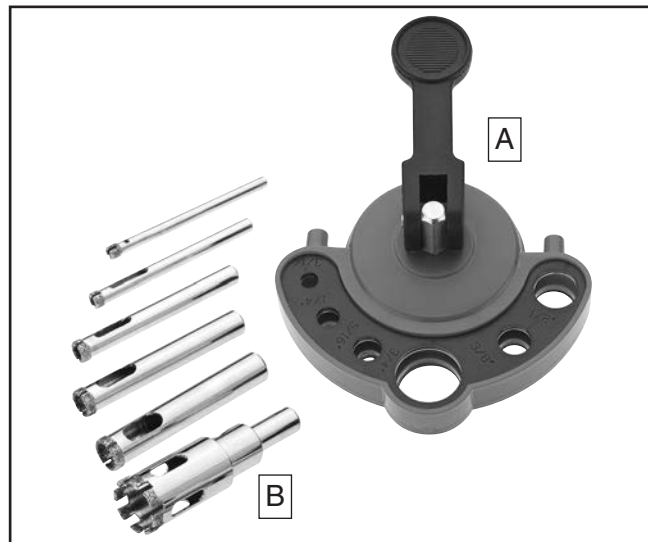

Figure 1. Model T10537 drill bit set.

Inventory

Description	Qty
A. Drilling Guide.....	1
B. Bits 3/16", 1/4", 5/16", 3/8", 1/2", 3/4".....	1 Ea.

NOTICE

DO NOT use diamond bits to drill through tempered glass, as it will shatter.

WARNING

Eye injuries, respiratory problems, or hearing loss can occur while operating this tool. Wear personal protective equipment to reduce your risk from these hazards.

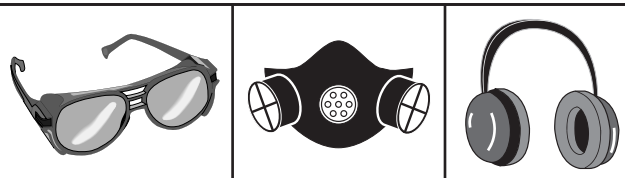

Drilling Speeds

Use the chart below to select the appropriate drilling speed (RPM) for the bit.

IMPORTANT: Use only light to medium pressure when drilling. Increased pressure *will not* increase cutting speed. Always ensure drill bit is properly lubricated with water to prolong bit life and ensure clean cuts.

Bit Size	Fiberglass	Glass/ Ceramic Tile	Granite/ Porcelain
3/16" - 3/8"	1100 RPM	700 RPM	350 RPM
3/8" - 1/2"	800 RPM	550 RPM	300 RPM
1/2" - 3/4"	600 RPM	450 RPM	250 RPM

NOTICE

To prolong bit life and ensure clean cuts, only apply light pressure to workpiece, use appropriate drill speed for material, and thoroughly lubricate drill bit with water.

COPYRIGHT © APRIL, 2012 BY GRIZZLY INDUSTRIAL, INC.

WARNING: NO PORTION OF THIS MANUAL MAY BE REPRODUCED IN ANY SHAPE OR FORM WITHOUT THE WRITTEN APPROVAL OF GRIZZLY INDUSTRIAL, INC.

#BL14977 PRINTED IN CHINA, REVISED SEPTEMBER, 2016 (JH)

Guide Setup & Operation

If using a handheld drill, always use the included guide to keep the bit centered.

To set up and operate guide:

1. Press guide down onto workpiece, then flip lock lever, as shown in **Figure 2**, to secure guide down.

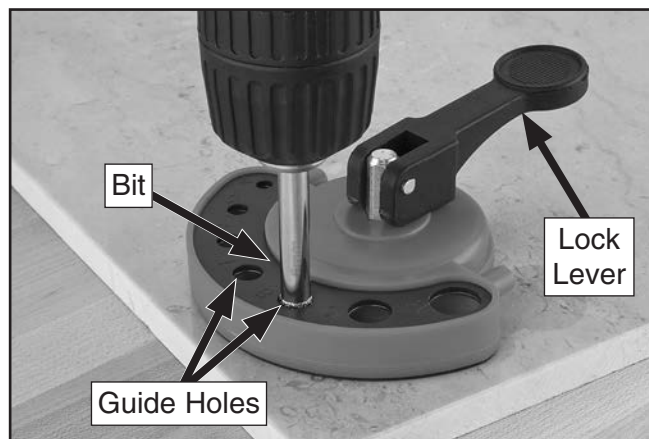

Figure 2. Model T10537 guide set up for drilling.

2. Tug guide to ensure it is secure. If it moves, release lock lever and repeat **Step 1**.
3. Add a small amount of water into guide hole that matches bit size.
4. Insert bit into matching guide hole, turn drill **ON**, and begin drilling.
5. Add water to guide hole to maintain slurry.
6. When hole is completed, unlock lever and remove guide.

To remove plug from drill bit:

1. Spray water into access channels on side of drill bit to remove built-up slurry.
2. Tap drill bit lightly against a soft piece of wood to loosen plug.

Note: After clearing built-up slurry from bit, a flat head screwdriver can be inserted into access channels to push pug from drill bit.

3. Remove plug and clean drill bit.

Operation Tips

- To reduce chip-out or breakage, place a backing board to support the workpiece and reduce pressure when finishing the hole.
- Make sure the workpiece is clean and moist so the suction cup grips the workpiece.
- Use an eye dropper or spray bottle to add a small amount of water to the drilling area (e.g. 1 teaspoon at a time). Avoid using oil-based lubricants.
- Harder materials may require a constant flow of water to properly lubricate and keep drill bit cool during use.
- The amount of water required to properly lubricate the bit depends on the porosity of the workpiece. A good rule of thumb is to start with a puddle of water approximately the same diameter as the bit. Non-porous material, such as glass or marble, may not need additional water (depending on the thickness). Porous material, such as slate or tile, will slowly absorb water, which will require replacement. Most importantly, never allow the bit to run dry.
- As the groove gets deeper, move the bit up and down while drilling to allow water to flow back into the cutting groove, cooling the bit. Add water if the slurry become too thick.
- Use minimal pressure while drilling to avoid breaking the workpiece. Allow the drill bit to do the work.
- The drill bit should never be hot to the touch. Decrease pressure, increase lubrication, or change drilling speed to keep bit cool.
- Always use the guide when drilling with a handheld drill.
- Never use the bits in an impact hammer. Doing so will cause the tip of the bit to split and shatter the workpiece.
- Follow all safety and operation instructions for your drill press or handheld drill. Avoid exposing electrical equipment to water as contact with water could cause electrocution.

