



MODEL T24103 2 HP 230V 3-PHASE MAGNETIC SWITCH INSTRUCTIONS



Figure 1. Model T24103 magnetic switch.

⚠ WARNING
Electrocution or fire could occur if this switch is not installed or adjusted by a qualified electrician!

←→
Contactor TECO CU-16 (230V Coil)

COLOR KEY	
BLACK	— Bk —
GREEN	— Gn —
RED	— Rd —
YELLOW	— Yl —

←→
Thermal Overload Relay
TECO RHU-10K1
(7.2–10A)

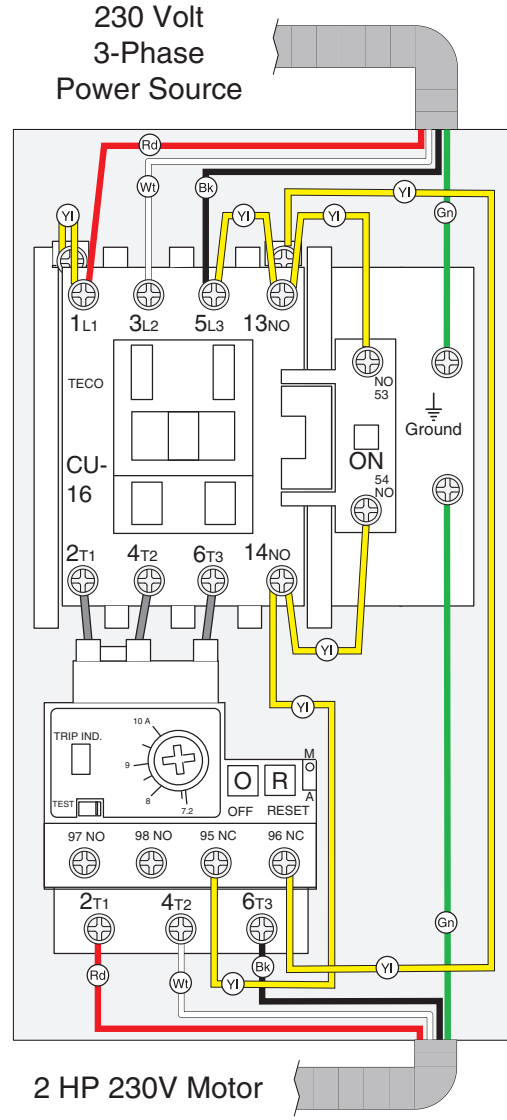

OPERATION: When pushed, the green ON button on the outside cover of the magnetic switch energizes a magnetic coil, which pulls the contactor closed. The main current then passes through the contactor and thermal overload relay to the motor. The red OFF button breaks the magnetic field, which opens the contactor and disconnects the current to the motor. A motor overload or an interruption of the power supply will also break the magnetic field and release the contactor and disconnect current to the motor. The motor will not re-start until the overload is reset and/or the ON button is pushed.

Thermal Relay Overload Amp Adjustment Dial: Turn this dial to the amperage setting specified by the motor manufacturer. Typically, this setting is 100–110% of the amperage load listed on the motor data plate. Please note that turning this dial has no effect on increasing motor horsepower. If turned too high, the motor can overheat and be damaged before the relay trips.

Trip Indicator: If this window turns yellow, the thermal relay has tripped.

Manual Trip Test Lever: If the thermal relay function is in question, run the motor and use a wooden toothpick to slide the yellow test lever to the left. If the motor shuts off, the thermal relay has tripped and is functional.

Manual Contactor Override Lug: When pushed, the contactor is manually closed for troubleshooting purposes only.

ON Button: When pushed, power is sent to the magnetic field coil, closing the contactor and sending power to the motor.

Manual/Auto Reset Lever: In the up position, the thermal relay is in manual reset mode. This means you must re-install the outside cover and push the red OFF button, then push the green ON button to reset the thermal relay. In the down position, the thermal relay will automatically reset when it has cooled.

Reset Button: When pushed, the thermal relay is reset, clearing the yellow trip indicator window.

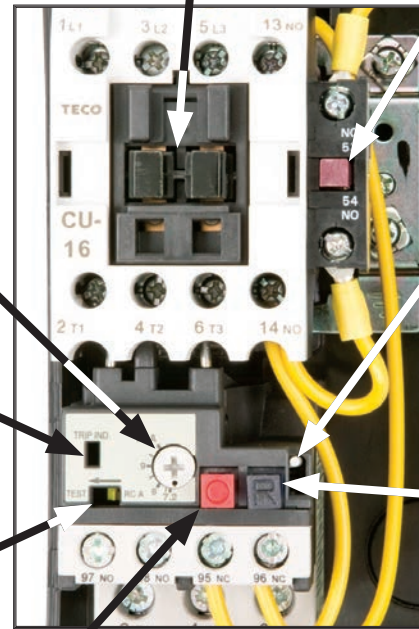

OFF Button: When pushed, the current going to the magnetic field coil is cut, which opens the contactor and cuts power to the motor.

Parts Breakdown

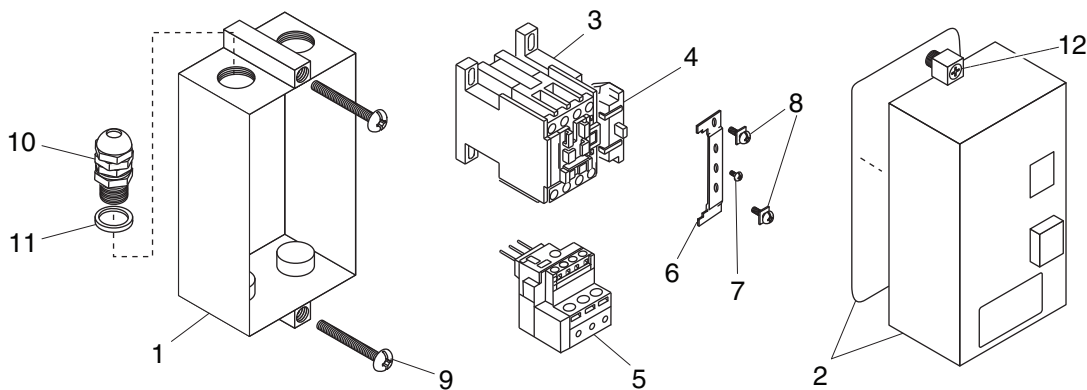

REF	DESCRIPTION
1	SWITCH BOX
2	SWITCH BOX COVER ASSEMBLY
3	CONTACTOR TECO CU-16 230V
4	FIELD SWITCH TECO CNA-1
5	OL RELAY TECO RHU-10K1 7.2-10A
6	GROUNDING PLATE

REF	DESCRIPTION
7	PHLP HD SCR M3-.5 X 10
8	CAPTURED GROUND SCR M4-.7 X 10
9	PHLP HD SCR 10-24 X 1-1/2
10	LIQUID-TITE STRAIN RELIEF
11	RUBBER SEAL
12	PLASTC SCREW M10-1.5 X 20 GRAY

