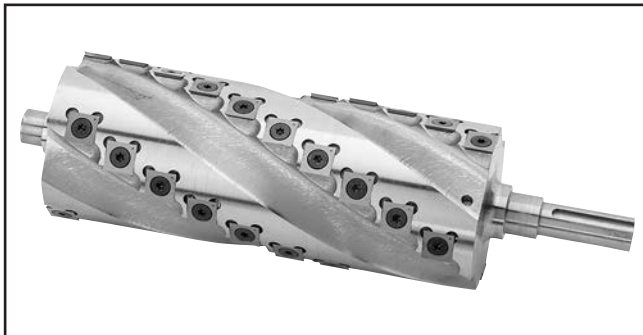




# MODEL T27449 8" SPIRAL CUTTERHEAD INSTALLATION INSTRUCTIONS

The Model T27449 indexable insert spiral cutterhead is designed to replace the straight-knife cutterhead on the Grizzly jointer Model G0490W/G0490XW 8" Jointer.



**Figure 1.** T27449 Spiral Cutterhead.

It takes approximately one hour to install this cutterhead and re-adjust the jointer. The job consists of (1) removing the old cutterhead, (2) installing/shimming the new spiral cutterhead, and (3) re-adjusting the outfeed table to be even with the carbide inserts at TDC (top dead center).

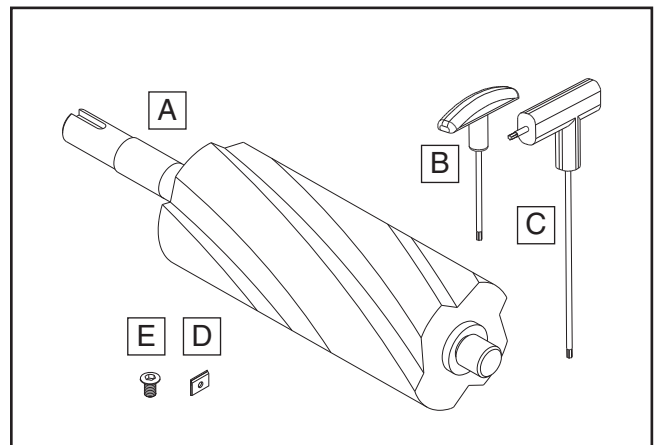
**Note:** We strongly recommend replacing the old cutterhead bearings during this installation. This model uses 6203-2RS and 6204-2RS bearings (one of each).

## Specifications

Length.....	8"
Diameter.....	3"
Number of Spirals.....	4
Number of Inserts.....	40
Insert Size.....	14 x 14 x 2mm
Insert Screw Thread Size.....	M6-1
Shaft Diameter (Long Side).....	20mm
Shaft Diameter (Short Side).....	17mm
Weight.....	18 lbs.

## Inventory (Figure 2)

A.	Spiral Cutterhead.....	1
B.	T-Handle Torx Driver T20.....	1
C.	L-Handle Torx Driver T-20.....	1
D.	Indexable Carbide Inserts 14 x 14 x 2.....	5
E.	Flat Head Torx Screws T20 M6-1 x 15.....	5



**Figure 2.** Spiral cutterhead inventory.

## Recommended Tools

Hex Wrench 4, 6mm.....	1 Ea.
Wrench/Socket 10, 13, 17, 19mm.....	1 Ea.
Precision Straightedge.....	1
Feeler Gauge Set.....	1
Heavy Leather Gloves.....	1 Pair
Safety Glasses.....	1
Pulley Puller.....	1
Rubber Dead Blow Hammer.....	1
Wood Block 12" 4x4.....	1
Wood Blocks 8" 2x4.....	2
Shop Rag.....	1

COPYRIGHT © FEBRUARY 2016 BY GRIZZLY INDUSTRIAL, INC.

**WARNING: NO PORTION OF THIS MANUAL MAY BE REPRODUCED IN ANY SHAPE OR FORM WITHOUT THE WRITTEN APPROVAL OF GRIZZLY INDUSTRIAL, INC.**

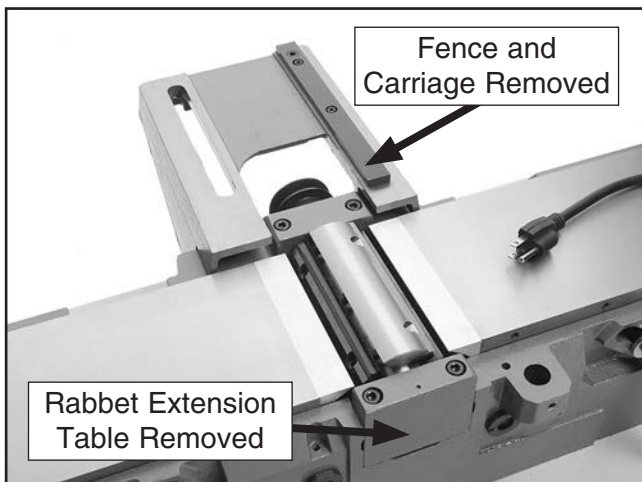
#MC17953 PRINTED IN CHINA

## Installation

1. DISCONNECT MACHINE FROM POWER!
2. Remove the jointer fence, cutterhead guard, and belt guard.
3. Remove the rabbet extension table, rear cover and belt guard, then remove the belt from the pulleys.
4. Loosen the infeed and outfeed table locks, then loosen the jam nuts and positive stop bolts located at the back of the machine.

**Note:** When lowering, make sure that the fence support does not come in contact with the cutterhead pulley.

5. Lower both beds to make enough room for the cutterhead to come out, as shown in **Figure 3**.



**Figure 3.** Example of a typical jointer disassembled from **Steps 1–5**.

6. Remove the knives or reverse their mounting direction so the blades face toward the cutterhead.

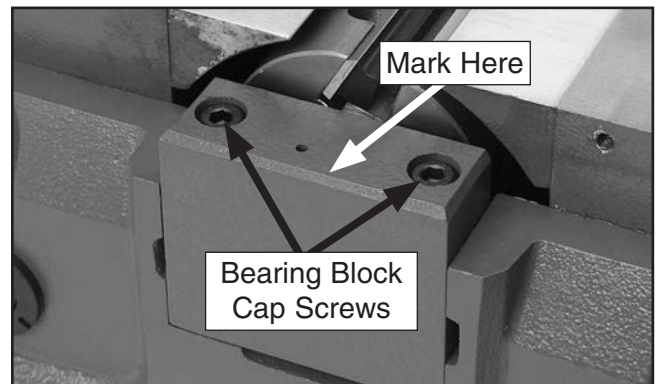
### **⚠️ WARNING**

Jointer knives are extremely sharp. You must remove the jointer knives, or mount the knives blade side down to avoid the risk of serious personal injury during the following steps.

7. Remove the cap screw and flat washer securing the cutterhead pulley, then remove the pulley and the key from the cutterhead.

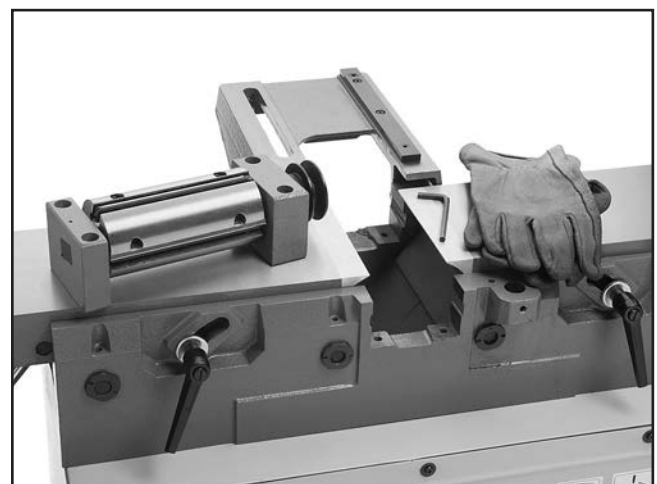
—If the pulley is difficult to remove, use a pulley puller (see **Accessories, Page 6**).

8. Remove the cap screws and lock washers that secure both bearing blocks, as shown in **Figure 4**.



**Figure 4.** Location of cap screws and lock washers on front bearing block.

9. Mark the side of the front bearing block that faces the front of the machine (see **Figure 4**) with tape or a felt marker, to make it easier to re-install the bearing blocks later.
10. Carefully remove the bearing blocks and cutterhead from the casting (see **Figure 5**).



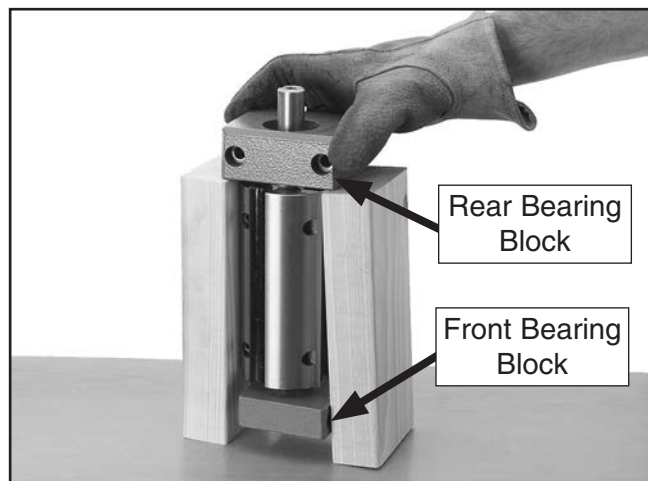
**Figure 5.** Example of cutterhead removed from a typical jointer.



**Note:** Your cutterhead may have paper or metal shims stuck to the bearing block or the part of the casting where the bearing block rests. These were included at the factory when they calibrated your cutterhead even with the outfeed table. If you see these, carefully pull them off and set them aside for later use, or keep them with your cutterhead in the event that you re-install it later. Also, mark the side of the cutterhead where they were used, so the future install will go smoothly. Your new cutterhead may or may not need these.

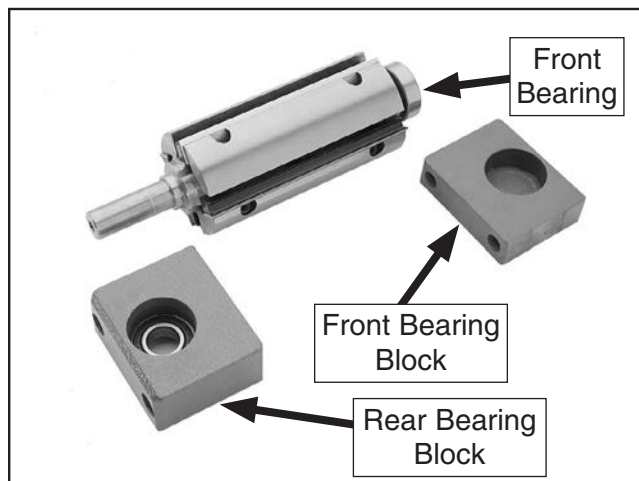
11. Cut a 2x4 into two 8" pieces.
12. Place the cutterhead assembly on a workbench or flat surface, with the pulley side of the cutterhead shaft facing up, then place the 2x4 blocks under the rear bearing block, as shown in **Figure 6**.

**Note:** Wrapping tape around the blocks can help hold them together during the next step.



**Figure 6.** Removing rear bearing block.

13. Tap the top of the cutterhead shaft with a rubber dead blow hammer and a 4x4 block. This should separate the cutterhead from the rear bearing block.
14. Remove the front bearing block and bearing from the cutterhead—if it has not already dropped off. **Figure 7** shows the disassembled components.

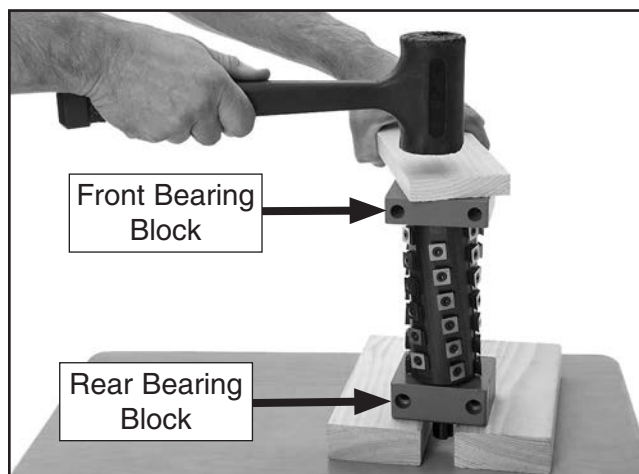


**Figure 7.** Disassembled cutterhead assembly.

## ⚠ WARNING

**Jointer carbide inserts are extremely sharp. Wear leather gloves to avoid the risk of serious personal injury during the following steps.**

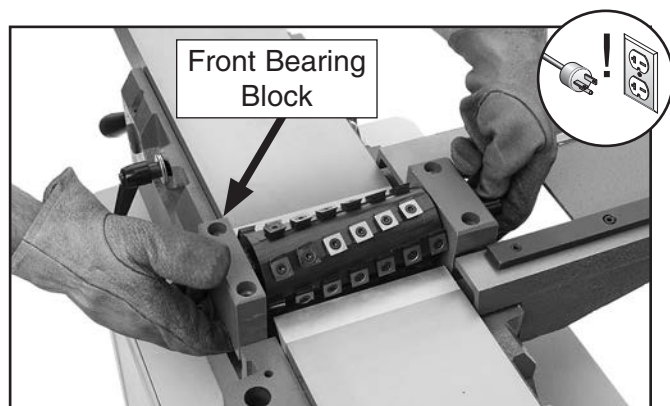
15. Install the new 6203-2RS bearing onto the front end (shorter shaft) of your Model T27449 spiral cutterhead, then press the bearing into the front bearing block removed in **Step 14**.
16. Remove bearing from the rear bearing block, then press in the new 6204-2RS bearing.
17. Stand the cutterhead upright between the two 8" 2x4 blocks. Use a piece of scrap wood and a dead blow hammer to seat the cutterhead into the bearing blocks, as shown in **Figure 8**.



**Figure 8.** Example of seating rear bearing block onto spiral cutterhead (T27449 not shown).

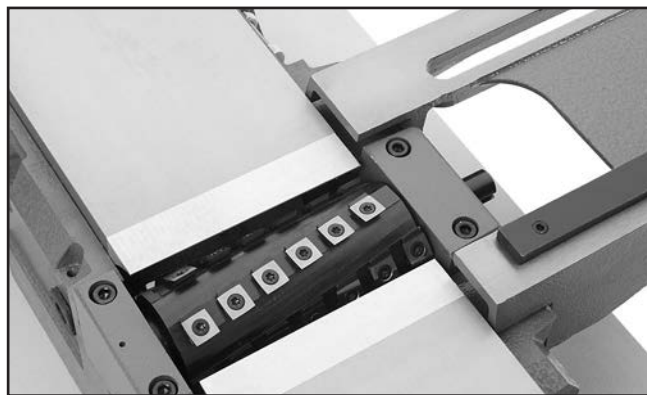


18. Use a rag to wipe sawdust off the part of the casting where the bearing blocks will rest.
19. While keeping the bearing blocks pressed against the spiral cutterhead, move the cutterhead to the jointer. Using the mark from **Step 9**, install the cutterhead so the front bearing block is positioned at the front of the machine (see **Figure 9**). Be careful not to chip the carbide inserts on the jointer beds.



**Figure 9.** Example picture of a spiral cutterhead being installed (T27449 not shown).

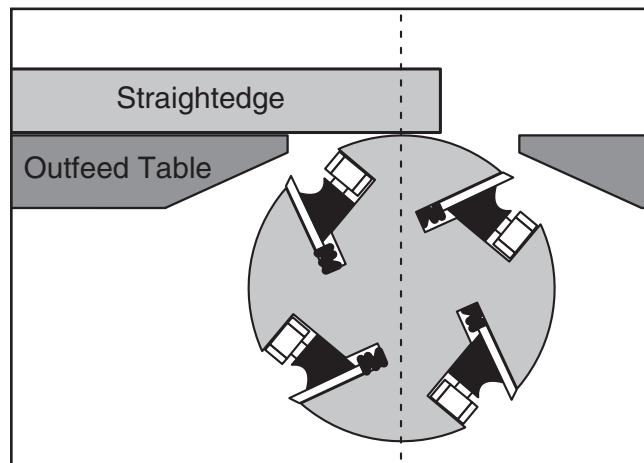
20. Secure the bearing blocks with the cap screws and lock washers removed in **Step 8** (see **Figure 10**).



**Figure 10.** Example picture of spiral cutterhead installed (T27449 not shown).

21. Install the key on the cutterhead keyway, push the pulley onto the cutterhead shaft, then secure the pulley with the cap screw and flat washer removed in **Step 7**. Ensure both pulley set screws are tight.

22. Using the straightedge and feeler gauge set, inspect the cutterhead parallelism with the outfeed table, as shown in **Figure 11**. With the straightedge in position, raise or lower the outfeed table until the cutterhead body (not the carbide insert) just touches the straightedge.



**Figure 11.** Checking cutterhead parallelism.

23. Move the straightedge to the other side to determine if one end of the cutterhead body is higher/lower than the other. (Place the feeler gauge between the cutterhead body and the straightedge to determine the height difference.)

—If the cutterhead is even or within 0.004" with the outfeed table from one side to the other, skip to **Step 25**.

—If the cutterhead is over 0.004" from one side to the other, go to **Step 23**.

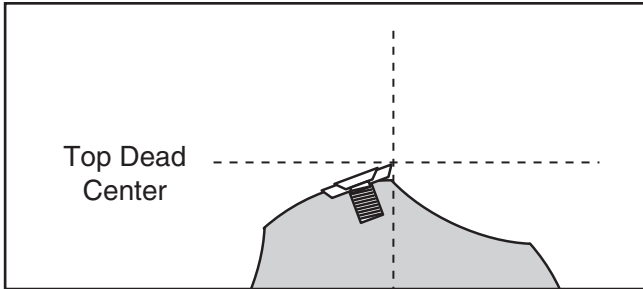
24. Loosen the cap screws securing the bearing blocks, lift the spiral cutterhead slightly, then place a shim beneath the bearing block that needs to be adjusted.

**Note:** Use the shims from your old cutterhead if available. If not available, newspaper is approximately 0.003" thick and will work for shimming (we don't recommend shimming more than 0.004" on either side, as this may affect how the bearing block seats in the casting).

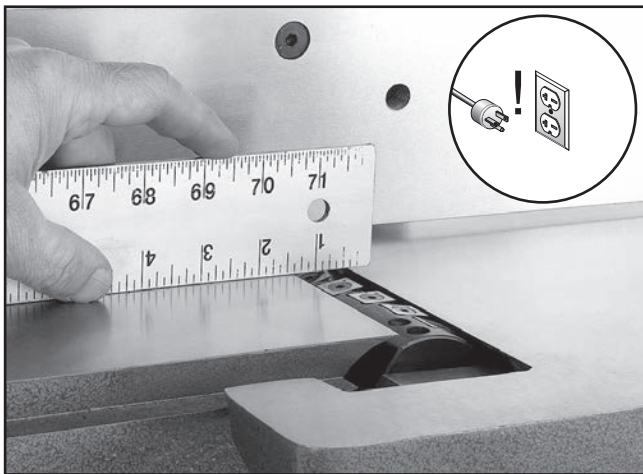
25. Repeat **Steps 22–24** and adjust if necessary, then tighten the cap screws on the bearing block studs.



26. Re-install the belt on the pulleys. (Refer to the instructions in your jointer manual for details.)
27. Place a straightedge on the outfeed table so it extends over the cutterhead, and rotate the cutterhead pulley until one of the carbide inserts is at top-dead-center (TDC), as shown in **Figures 12 & 13**.

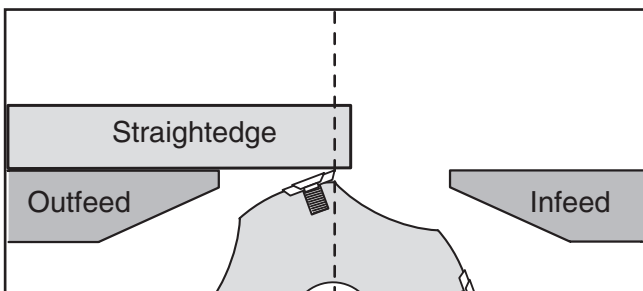


**Figure 12.** Cutterhead insert at top-dead-center.



**Figure 13.** Setting outfeed table height.

When correctly set, the carbide insert will just touch the straightedge when the insert is at its highest point of rotation (see **Figure 14**).



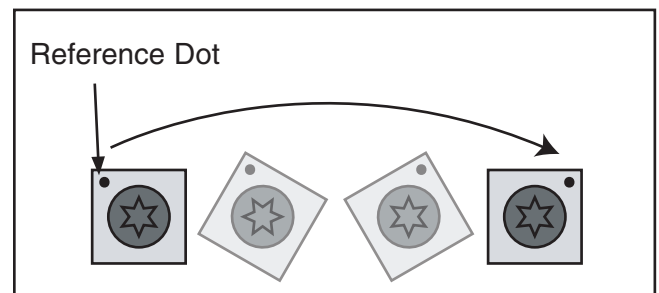
**Figure 14.** Using a straightedge to align outfeed table height with insert at TDC.

- If your outfeed table is correctly set, no adjustments are necessary.
- If the insert lifts the straightedge off the table or the table is below the straightedge, adjust the outfeed table height with the outfeed table adjustment lever until the straightedge just touches an insert at its highest point of rotation.

28. Lock the outfeed table, then re-install the fence.
29. Install the cutterhead guard back over the cutterhead, making sure that the spring tension in the guard is properly set so the guard springs back over the cutterhead when it is pulled back and released.
30. Re-adjust the infeed table.
31. Re-install the rabbet extension table, belt cover, and rear cover.
32. Reset the positive stop bolts on the infeed and outfeed tables.

### Insert Service

The Model T27449 8" cutterhead is equipped with 40 indexable carbide inserts. Each insert can be rotated to reveal any one of its four cutting edges. Therefore, if one cutting edge becomes dull or damaged, simply rotate it clockwise 90° to reveal a fresh cutting edge (see **Figure 15**).



**Figure 15.** Rotating indexable carbide inserts.



In addition, each insert has a reference dot on one corner. As the insert is rotated, the reference dot location can be used as an indicator of which edges are used and which are new. The insert must be replaced when all four edges are dull.

**To install or adjust a carbide cutter:**

1. DISCONNECT MACHINE FROM POWER!
2. Remove any sawdust from the head of the carbide insert Torx screw.
3. Remove the Torx screw and carbide insert.
4. Clean all dust and dirt off the insert and the cutterhead pocket from which the insert was removed, and replace the insert so a fresh, sharp edge is facing outward.

**Note:** *Proper cleaning is critical to achieving a smooth finish. Dirt or dust trapped between the insert and cutterhead will slightly raise the insert, and make noticeable marks on your workpieces the next time you cut.*

5. Lubricate the Torx screw threads with a light machine oil, wipe the excess oil off the threads, and torque the Torx screw to 48-50 inch/pounds.

**Note:** *Excess oil may squeeze between the insert and cutterhead or in the screw hole, thereby lifting the insert or screw slightly and affecting workpiece finishes.*

## Accessories

### G8995—4" Heavy-Duty Pulley Puller

Indispensable for pulling gears or pulley off of press-fit shafts. Can be used in either a 2 or 3 jaw configuration. The 4" jaw fingers are also reversible so they can grab an outside or inside diameter. The forcing screw has a live center and is made of tough hardened steel.

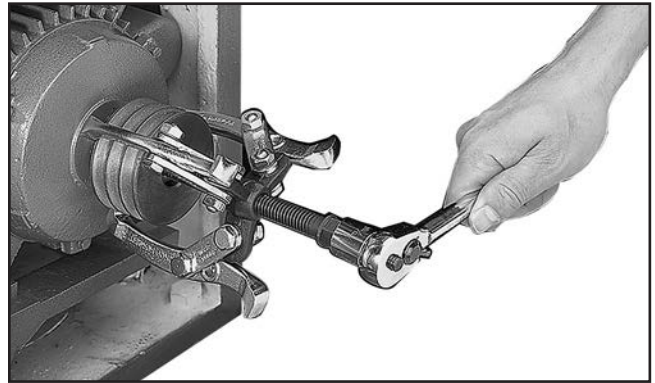


Figure 16. G8995 4" Heavy-Duty Pulley Puller.

### H7319—10 Pack of Indexable Carbide Inserts

Replacement carbide inserts for T27449 cutterheads.

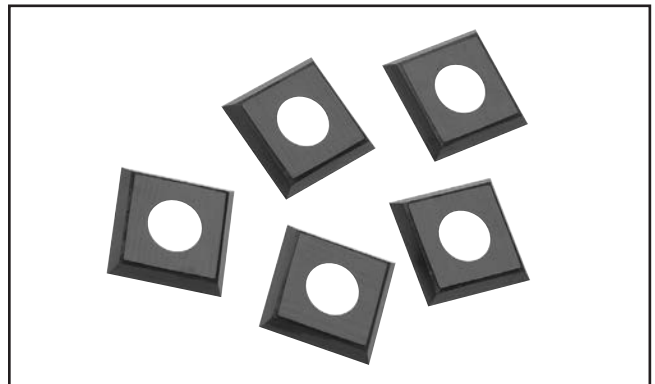


Figure 17. H7319 Indexable Carbide Inserts.

### G9644—12" Precision Straightedge

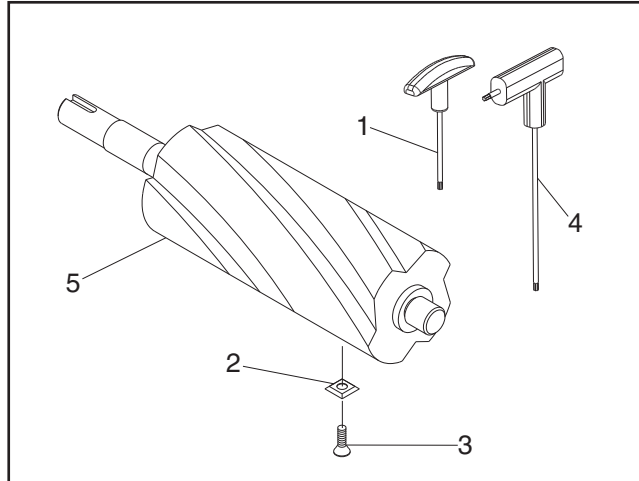
### H2675—16" Precision Straightedge



Figure 18. Precision straightedges.



# T27449 Parts Breakdown and List



REF	PART #	DESCRIPTION
1	PT27449001	T-HANDLE TORX DRIVE T-20
2	PT27449002	INDEXABLE INSERT 14 X 14 X 2
3	PT27449003	FLAT HD TORX SCR T20 M6-1 X 15
4	PT27449004	L-HANDLE TORX DRIVE T-20
5	PT27449005	SPIRAL CUTTERHEAD 8"



***grizzly.com***®  
**TOOL WEBSITE**

Buy Direct and Save with Grizzly® – Trusted, Proven and a Great Value!  
~Since 1983~

*Visit Our Website Today For  
Current Specials!*

**ORDER  
24 HOURS A DAY!  
1-800-523-4777**

