



MODEL T28000/T28922/T28923 HEAVY-DUTY MOBILE BASE INSTRUCTIONS

For questions or help with this product contact Tech Support at (570) 546-9663 or techsupport@grizzly.com

Introduction

Your new Heavy-Duty Mobile Base is designed to give you a stable and mobile platform upon which to mount machinery and equipment.

Inventory

Description	Qty
A. Right Front Corner Bracket	1
B. Left Front Corner Bracket.....	1
C. Right Rear Corner Bracket.....	1
D. Left Rear Corner Bracket	1
E. 21" Side Rails (T28000)	4
14" Side Rails (T28922) (Not Shown).....	4
21" Side Rails (T28923) (Not Shown).....	2
26" Side Rails (T28923) (Not Shown)	2
F. 3" Swivel Casters	2
G. 3" Wheels	2
H. Foot Pedals	4
I. Foot Pedal Springs.....	2
J. Foot Pedal Plungers.....	2
K. Adjustable Rubber Feet.....	2
L. Bearing Sleeves	4
M. Shoulder Bolts M10-1.5 x 55 (Casters).....	2
N. Shoulder Bolts M8-1.25 x 52 (Pedals).....	2
O. Hardware (Not Shown)	
—Hex Bolts M8-1.25 x 16 (Brackets)	24
—Hex Nuts M10-1.5 (Rubber Feet)	2
—Lock Nuts M8-1.25 (Caster/Pedal).....	10
—Lock Nuts M10-1.5 (Casters)	2

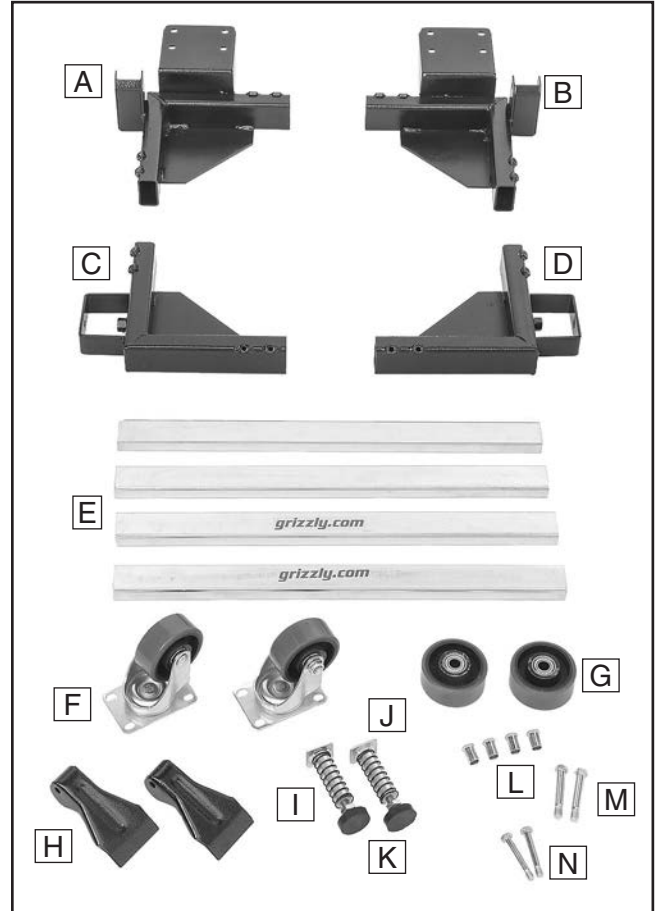

Figure 1. Inventory.

Specifications

T28000

- Minimum Inside Dimensions 19" x 21"
- Maximum Inside Dimensions .. 29½" x 29½"
- Maximum Weight Capacity 1200 lbs.

T28922

- Minimum Inside Dimensions 14" x 14"
- Maximum Inside Dimensions .. 22½" x 22½"
- Maximum Weight Capacity 900 lbs.

T28923

- Minimum Inside Dimensions 19" x 26"
- Maximum Inside Dimensions .. 29½" x 34½"
- Maximum Weight Capacity 1200 lbs.

⚠ WARNING

Operating machinery on an unsecured mobile base may allow the machine to shift unexpectedly, which could result in accidental contact with a cutting device or other moving parts.

Tools Needed for Assembly

- Open-End Wrench or Socket 13mm 1
- Open-End Wrench or Socket 14mm 1
- Open-End Wrench or Socket 17mm..... 1
- Measuring Tape..... 1

Preparation for Assembly

There is more than one way to assemble the mobile base. Each method has advantages and disadvantages, depending on the size and weight of the machine that you plan to put on the mobile base. The purpose of this section is to help you decide which method will work best for your situation.

If the machine can be lifted, the easiest method is to assemble the mobile base according to the dimensions of your machine, and then lift and place the machine on the corner bracket plates of the mobile base (see **Figure 2**). Proceed to **Assembling Base & Mounting Machine** on **Page 3** if your machine fits this situation.

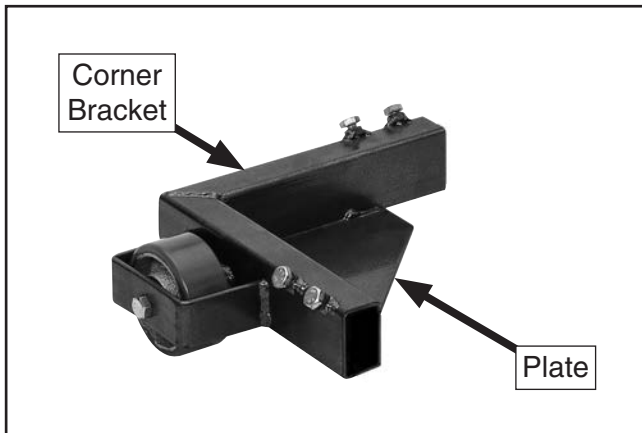

Figure 2. One of four corner brackets the machine will sit on.

If the machine is top heavy or has a narrow base (such as a drill press), there is an increased risk of tipping when moving it around on a mobile base. To reduce the risk, a mounting base plate should be used between the mobile base and machine. Proceed to **Making a Base Plate** on **Page 9** if your machine fits this situation.

If the machine is too heavy to lift into position on the mobile base, then the base can be built around the machine. Proceed to **Assembling Base Around Machine** on **Page 5** for instructions on how to build the base around the machine.

Note: Anything extending or opening outward with a 3" high band around the base of the machine (see **Figure 3**) may interfere with the installation of the machine on the base, so be sure to account for that prior to assembly.



Figure 3. Example of 3" high band around machine base.



Assembling Base & Mounting Machine

1. Attach swivel caster to each front corner bracket using (4) M8-1.25 x 16 hex bolts and (4) M8-1.25 lock nuts (see **Figure 4**).

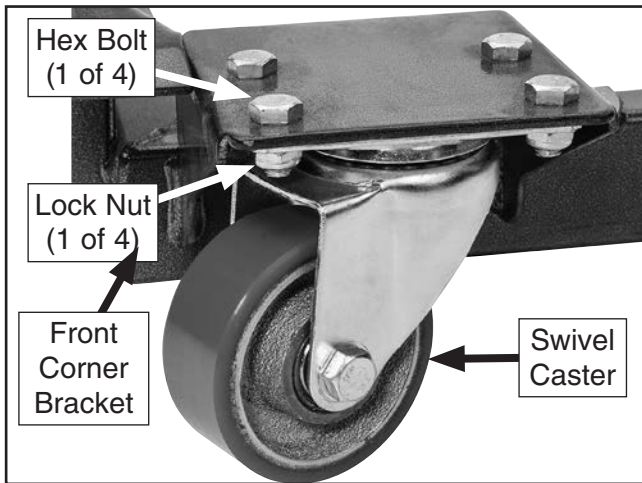

Figure 4. Swivel caster attached to front corner bracket.

2. Install foot pedal plunger and spring into each front corner bracket (see **Figure 5**), and attach a rubber foot (with M10-1.5 hex nut) to the bottom of each foot pedal plunger.

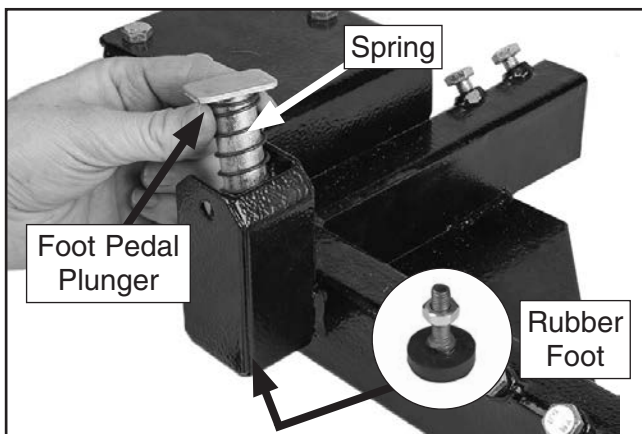

Figure 5. Installing foot pedal plunger and spring.

3. Attach foot pedal to each front corner bracket using (1) M8-1.25 x 52 shoulder bolt and (1) M8-1.25 lock nut (see **Figure 6**).

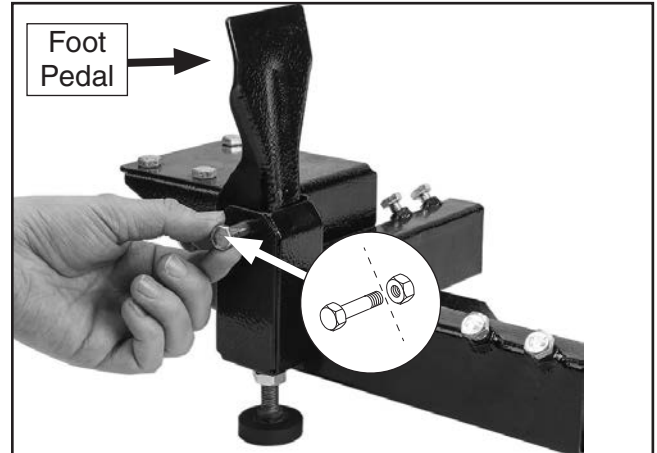

Figure 6. Attaching foot pedals.

4. Attach fixed caster wheels to each rear corner bracket using (1) M10-1.5 x 55 shoulder bolt and (1) bearing sleeve (see **Figure 7**).

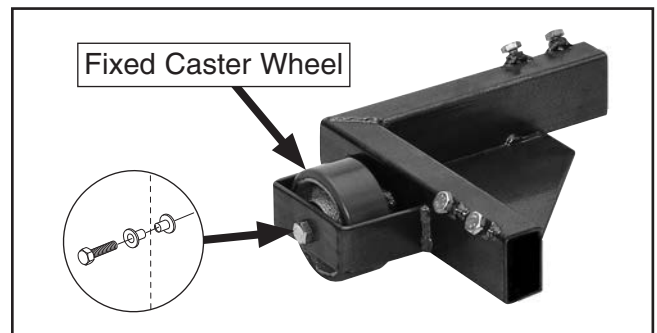

Figure 7. Fixed caster wheel installed on rear corner bracket.

5. Orient fixed casters in same direction machine will typically be moved (see **Figure 8**). Mounting fixed casters in wrong direction will make it difficult to move mobile base around in small spaces.

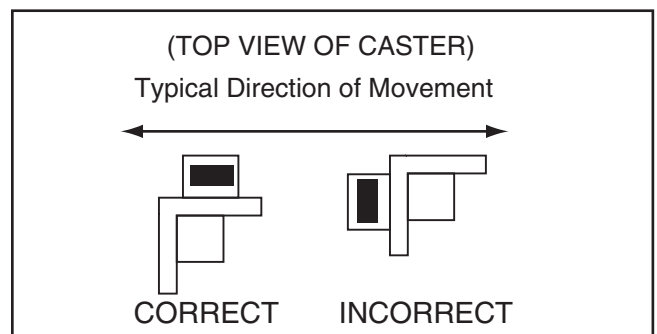

Figure 8. Orientation of fixed casters for easy machine movement.



6. Measure machine base footprint size.
7. Slide corner brackets over ends of side rails (see **Figure 9**). Position corner brackets so inside opening is $\frac{1}{4}$ "– $\frac{1}{2}$ " larger than both width and length of machine base footprint.

Note: Model T28923 only, make sure 21" bars and 26" bars of equal length are installed parallel to each other.

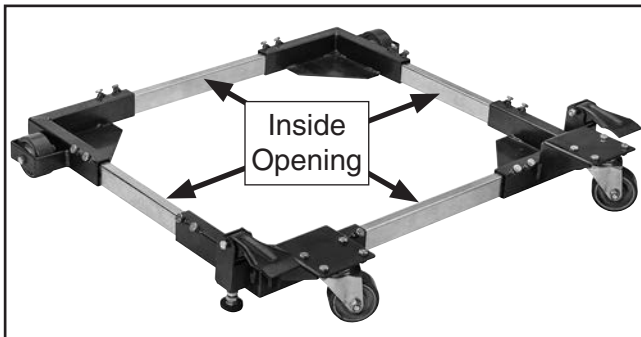

Figure 9. Properly assembled mobile base with inside opening slightly larger than machine base to ensure easy fit.

8. Secure each end of corner brackets with (2) M8-1.25 x 16 hex bolts (see **Figure 10**).

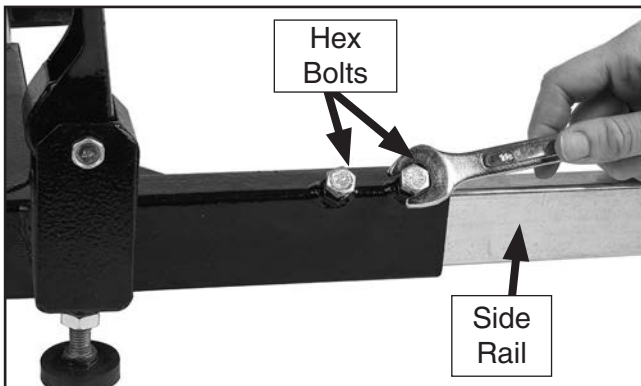

Figure 10. Securing corner bracket to rail with BOTH hex bolts.

⚠ CAUTION

BOTH hex bolts must be secured against side rail in each end of corner brackets. DO NOT load machine onto mobile base until all bolts have been firmly tightened. Improper tightening or using one bolt can result in collapse or tipping when moving machine, which could result in crushing injury or property damage. DO NOT overtighten bolts. Overtightening can strip threads.

9. With the help of an assistant, or proper lifting equipment, lift and position machine inside mobile base (see **Figure 11**).



Figure 11. Example of machine properly placed inside mobile base.

10. Verify machine is properly seated on mobile-base corner pads, it is free of wobbles, and there is no deflection in mobile base.

— **Deflection:** If any deflection exists, verify all fasteners are securely tightened and mobile base is properly assembled. If this does not solve the problem, verify machine does not exceed the rated weight limit listed in **Specifications** on **Page 1**.

— **Wobbles:** Wobbles can easily be eliminated by placing an appropriately sized shim between machine and mobile base where needed.



Assembling Base Around Machine

If your machine is oddly shaped or too heavy to lift into the mobile base, you can assemble the mobile base around your machine as an alternate option for assembly. Always have an assistant stabilize the machine during mobile base assembly.

Items Needed	Qty
Additional Person	1
Open-End Wrench 13mm.....	1
Socket Wrench 13mm	1
12" 4x4 Block.....	1
12" 2x4 Block.....	1

To assemble mobile base around machine:

1. Install foot pedal plunger and spring into each front corner bracket (see **Figure 12**), and attach a rubber foot (with M10-1.5 hex nut) to the bottom of each foot pedal plunger.

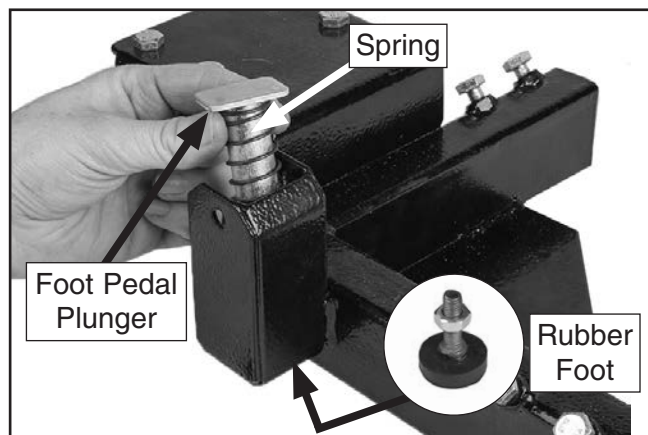

Figure 12. Installing foot pedal plunger and spring.

2. Attach each foot pedal to front corner bracket using (1) M8-1.25 x 52 shoulder bolts and (1) M8-1.25 lock nuts (see **Figure 13**).

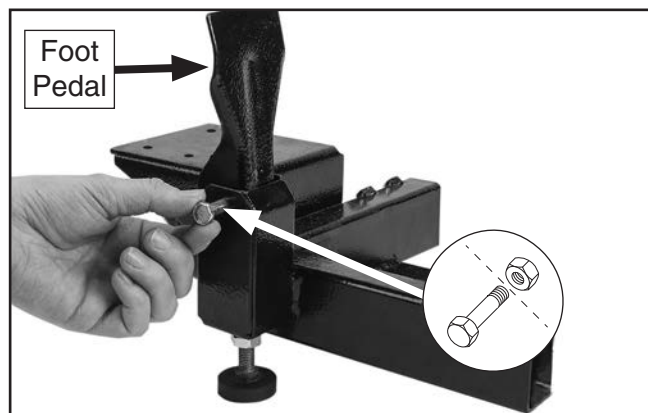

Figure 13. Attaching foot pedal to corner.

3. Insert one side rail into the two front brackets, as shown in **Figure 14**, then slide the bracket assembly against the side of machine that will typically be pushed against when moving the machine.

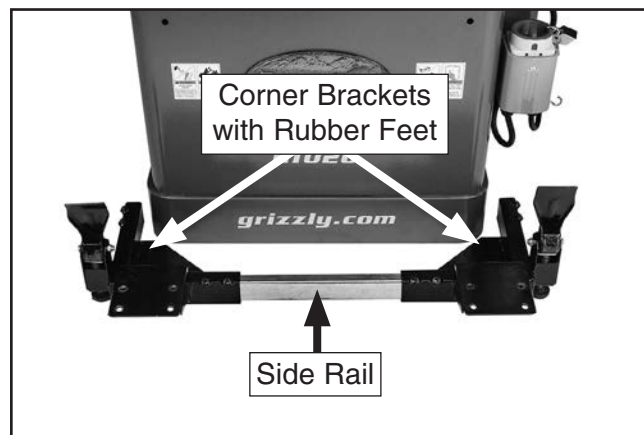

Figure 14. Rail inserted between corner brackets with rubber feet.

4. Secure each end of rail to corner brackets with (2) M8-1.25 x 16 hex bolts, as shown in **Figure 15**.

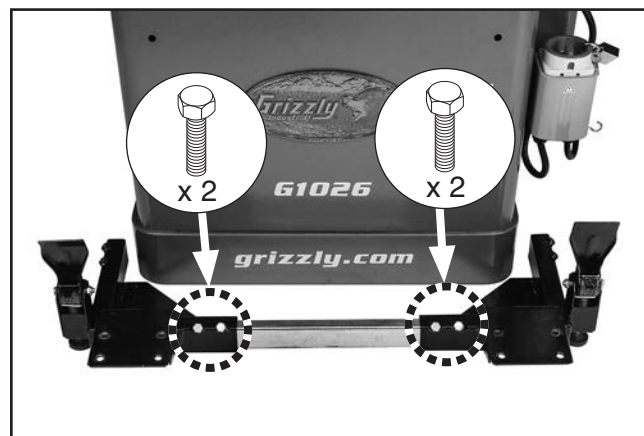

Figure 15. Rail secured to corner brackets.



- Slide other side rails into corner brackets from **Step 4**. Secure rails to corner brackets with (4) M8-1.25 x 16 hex bolts, as shown in **Figure 16**.

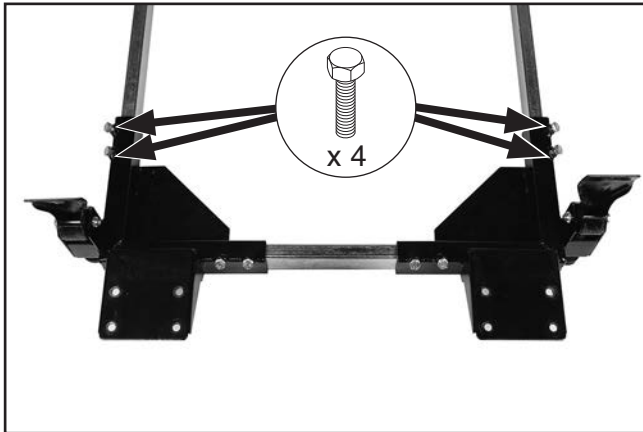

Figure 16. Rails fastened to brackets (machine removed for clarity).

- While an assistant lifts one side of the machine, slide rail-bracket assembly from **Step 5** under machine, as shown in **Figure 17**.

Note: It may be necessary to re-adjust position of rails once machine is actually on base assembly.

Side rails may be cut down to accommodate machines with smaller footprints. However, reducing length of mobile base decreases stability and increases likelihood of tipping tall or top-heavy machines. Base plates should be constructed for tall or top-heavy machines (see **Page 9**).



Figure 17. Rail-bracket assembly placed under front of machine.

- With the help of an assistant, lift rear side of machine, then place a 4x4 block under machine (see **Figure 18**).
- Slide each of the corner brackets onto remaining side rail, and slide assembly into rail-bracket assembly from **Step 6**. Adjust fit until rail-bracket assembly rests against machine body (see **Figure 18**).

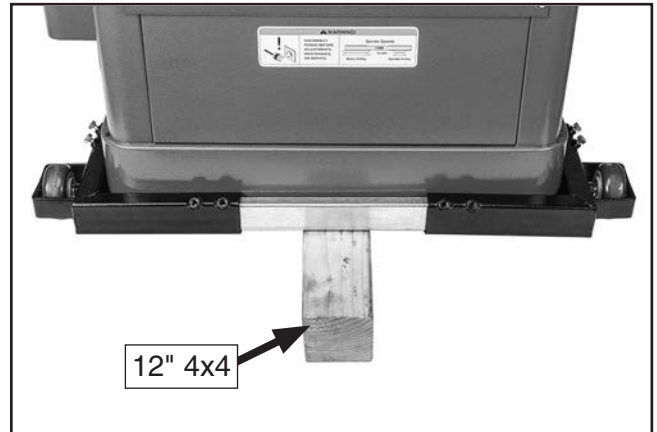

Figure 18. Remaining brackets and rail placed around back of machine, which is raised up with a wood block

- Secure rail to corner brackets using (4) M8-1.25 x 16 hex bolts, as shown in **Figure 19**.
- With machine still propped on 4x4 block, install both fixed wheels using (4) M10-1.5 x 55 shoulder bolts (see **Figure 19**).

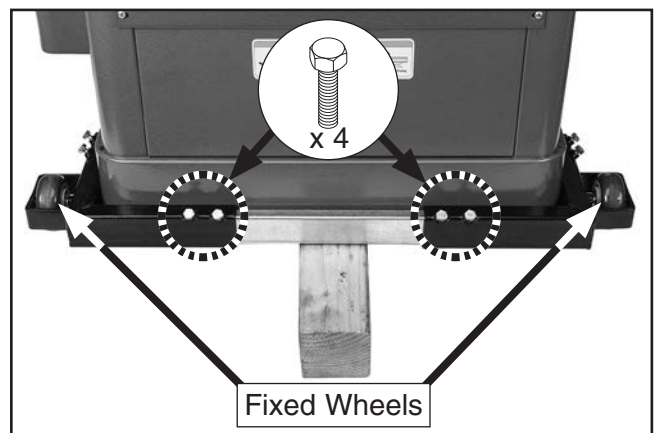

Figure 19. Remaining rail-bracket assembly secured.

- With the help of an assistant, shift machine to remove 4x4 block.



12. With the help of an assistant, tilt machine, and insert a 2x4 block beneath machine and mobile base frame (see **Figure 20**).



Figure 20. 2x4 Placed beneath machine and mobile base frame.

13. Attach swivel casters to each corner of assembly using (4) M8-1.25 x 16 hex bolts and (4) M8-1.25 lock nuts (see **Figure 21**).

Note: *There is limited space when installing fasteners inside the bottom of the caster wheels.*

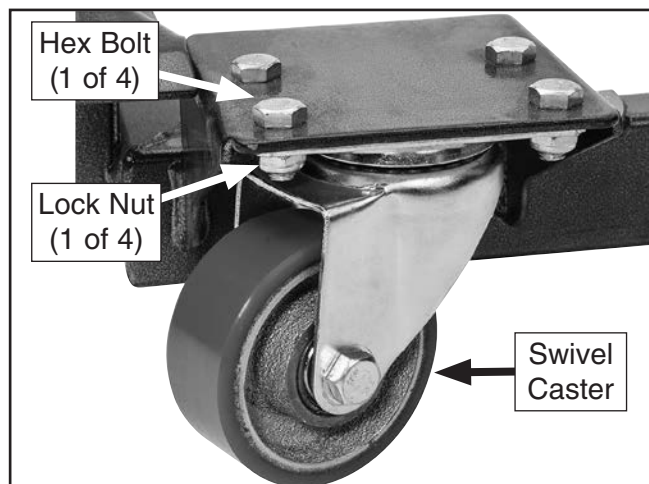

Figure 21. Swivel caster attached corner bracket.

14. With the help of an assistant, tilt machine and remove 2x4 block from beneath machine and mobile base frame, and set machine on the floor.

Note: *When moving the mobile base, the rubber feet should not touch the floor. However, when operating the machine, ensure that the rubber feet are fixed firmly against the floor to stabilize the machine.*

Adjusting Rubber Feet

The height of the rubber feet can be adjusted to stabilize the machine. To ensure the machine does not move during operations, always make sure the adjustable rubber feet (see **Figure 22**) are firmly touching the ground before operating the machine.

Tool Needed	Qty
Open-End Wrench 17mm.....	1

To adjust rubber foot height:

1. Loosen hex nut on each foot to allow foot (see **Figure 22**) to move up or down as needed.

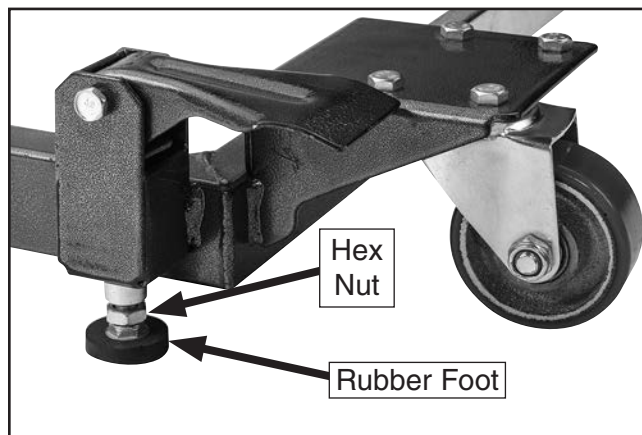

Figure 22. Rubber foot and hex nut adjustment.

2. With all casters on the ground, lower each foot to firmly touch the ground without lifting caster.
3. Tighten hex nut on each foot.

Continued on next page →



4. Raise foot pedals up to lift rubber feet and move machine (see **Figure 23**).

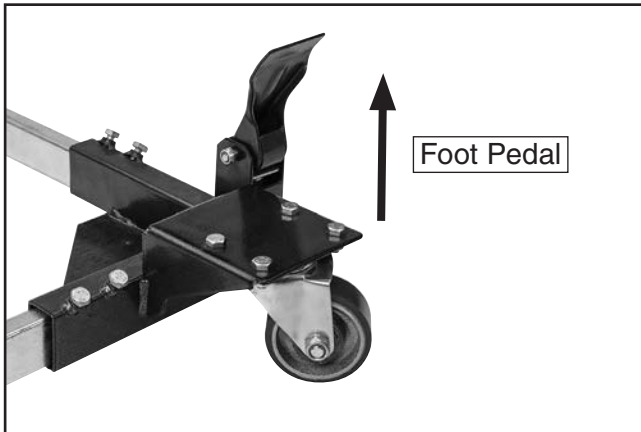

Figure 23. Foot pedal raised.

IMPORTANT: When moving the mobile base, the rubber feet should not touch the floor. Likewise, when operating the machine, ensure that the rubber feet are fixed firmly against the floor to provide stability, without lifting casters.

Using Mobile Base

1. DISCONNECT MACHINE FROM POWER!
2. With machine mounted on mobile base, lift foot pedals to raise rubber feet. If needed, adjust feet further to ensure feet do not drag during move. Refer to **Adjusting Rubber Feet** on **Page 7** for details.
 - If floor is uneven, retract feet completely to eliminate the chance of the pads dragging.
3. Check to make sure machine pathway is clear of all obstructions.
4. Push machine from lowest possible point to avoid tipping it over, and move it to its new location. The best control is usually achieved by pushing from swivel caster side of base.
 - If the machine is large, get an assistant to help stabilize the machine while it is being moved.
5. Adjust each foot until it touches floor, then rotate each foot so it firmly presses against ground without raising casters.
6. Check machine to make sure it is stable in its new location, and make sure machine is clear of any obstructions before reconnecting power and turning machine **ON**.

!WARNING

To reduce risk of serious injury when using this mobile base:

1. **LOCKING FEET.** Do not operate machine on mobile base unless both mobile base feet firmly contact floor and raise base enough to disable casters. Using the machine on base when it is not secured could result in a loss of workpiece control.
2. **MACHINE STABILITY.** Test for stability after placing the machine in its new location. Adjust feet so they each they touch the ground, then push on machine at several locations, making sure it is not off balance. The hex nuts can be adjusted up to top of foot assembly to lock foot height setting.



Making a Base Plate

If the footprint of the machine is too small for the mobile base or the machine doors or fixtures do not clear the side rails, you can mount it to a base plate, as shown in **Figure 24**.

A good quality base plate can increase the standard footprint of machines, such as drill presses, to make them more stable. The base plate should be approximately $\frac{3}{4}$ " thick and made of plywood (do not use OSB, MDF, or particle board) to hold the weight of the machine.

Note: A base plate should not be used with machines over 500 lbs. Base plate dimensions should not be more than twice the width of the machine base.

Needed Materials for Base Plate Qty

- Plywood $\frac{3}{4}$ " x Base Width x Base Length.. 1
- Hex Bolts $\frac{5}{16}$ " x $1\text{-}\frac{1}{4}$ " 4
- $\frac{5}{16}$ " Hex Nuts 4
- $\frac{5}{16}$ " Lock Washers 4
- $\frac{5}{16}$ " Flat Washers 8

1. Place plywood base plate on assembled mobile base (see **Page 3** for assembly instructions).
2. Drill $\frac{3}{8}$ " holes through base plate and bracket plates at each corner of mobile base.
3. Secure base plate to mobile base with $\frac{5}{16}$ " hex bolts, hex nuts, flat washers, and lock washers, as shown in **Figure 24**.

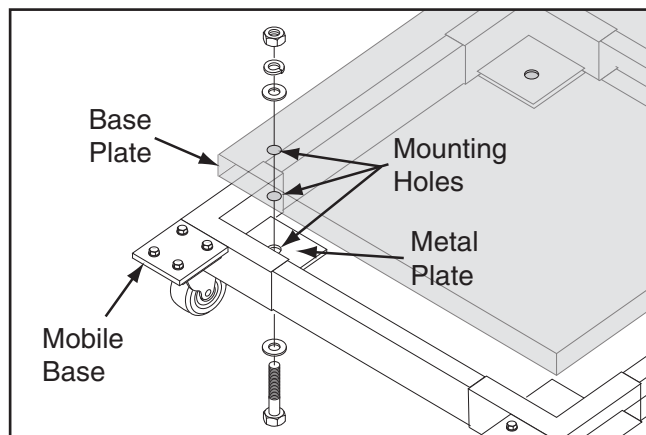

Figure 24. Example of mounting plywood base plate to mobile base.

4. Lower rubber feet to keep mobile base from moving (see **Page 7**).
5. With help from an assistant, place machine on base plate.
6. Position machine stand close to front or center of mobile base, so mobile base will not be a tripping hazard.
7. Drill holes through base plate and secure machine with through bolts, flat washers, lock washers, and hex nuts (see **Figure 25**).

Note: There is limited space underneath base plate, which can make it difficult to tighten fasteners. If needed, insert bolts from below and fasten washers and nuts from above.

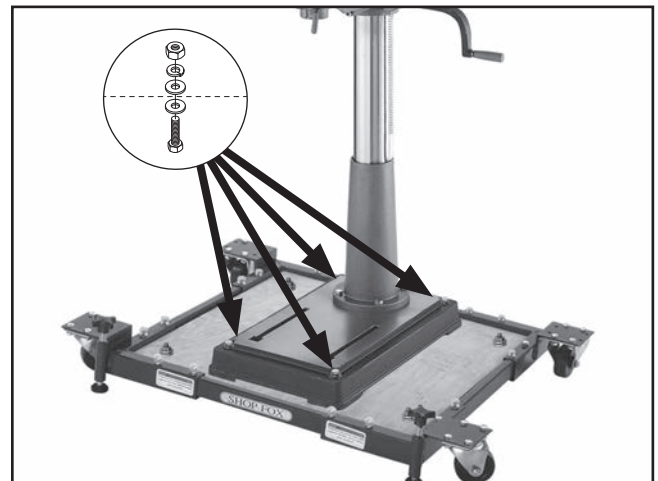
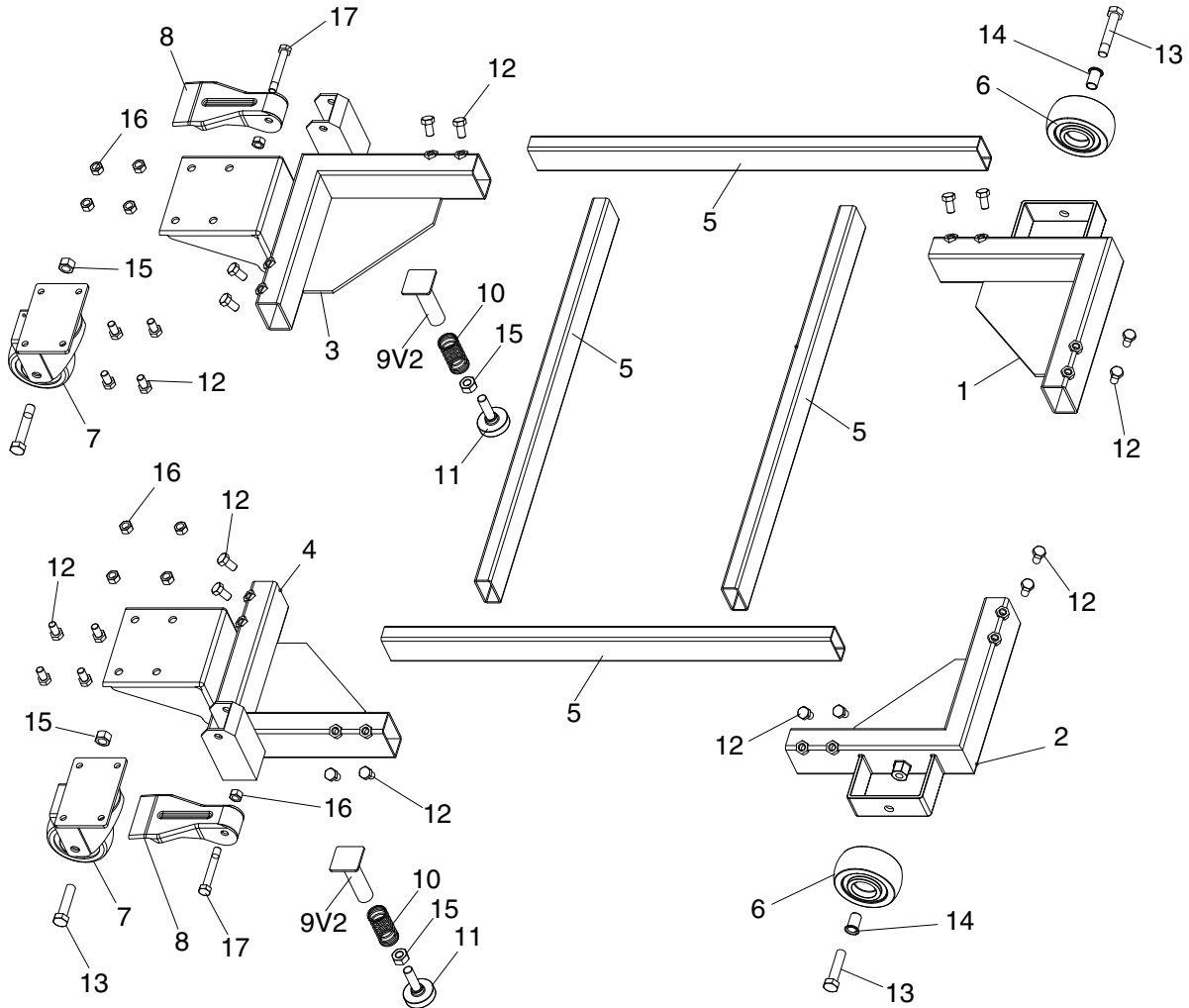

Figure 25. Example of drill press mounted to a base plate.



T28000, T28922 Parts Breakdown and List



REF	PART #	DESCRIPTION
1	PT28000001	LEFT REAR CORNER BRACKET
2	PT28000002	RIGHT REAR CORNER BRACKET
3	PT28000003	LEFT FRONT CORNER BRACKET
4	PT28000004	RIGHT FRONT CORNER BRACKET
5	PT28000005	RAIL 21" (T28000)
5	PT28922005	RAIL 14" (T28922)
6	PT28000006	CASTER, 3" FIXED
7	PT28000007	CASTER, 3" SWIVEL
8	PT28000008	FOOT PEDAL

REF	PART #	DESCRIPTION
9V2	PT28000009V2	FOOT PEDAL PLUNGER 17MM V2.07.17
10	PT28000010	COMPRESSION SPRING 22 X 1.5 X 61
11	PT28000011	ADJUSTABLE FOOT M10-1.5 X 30
12	PT28000012	HEX BOLT M8-1.25 X 16
13	PT28000013	SHOULDER BOLT M10-1.5 X 14, 10 X 55
14	PT28000014	WHEEL BEARING SLEEVE
15	PT28000015	HEX NUT M10-1.5
16	PT28000016	LOCK NUT M8-1.25
17	PT28000017	SHOULDER BOLT M8-1.25 X 8, 8 X 50

Please Note: We do our best to stock replacement parts whenever possible, but we cannot guarantee that all parts shown here are available for purchase. Call (800) 523-4777 or visit our online parts store at www.grizzly.com to check for availability.



T28923 Parts Breakdown and List

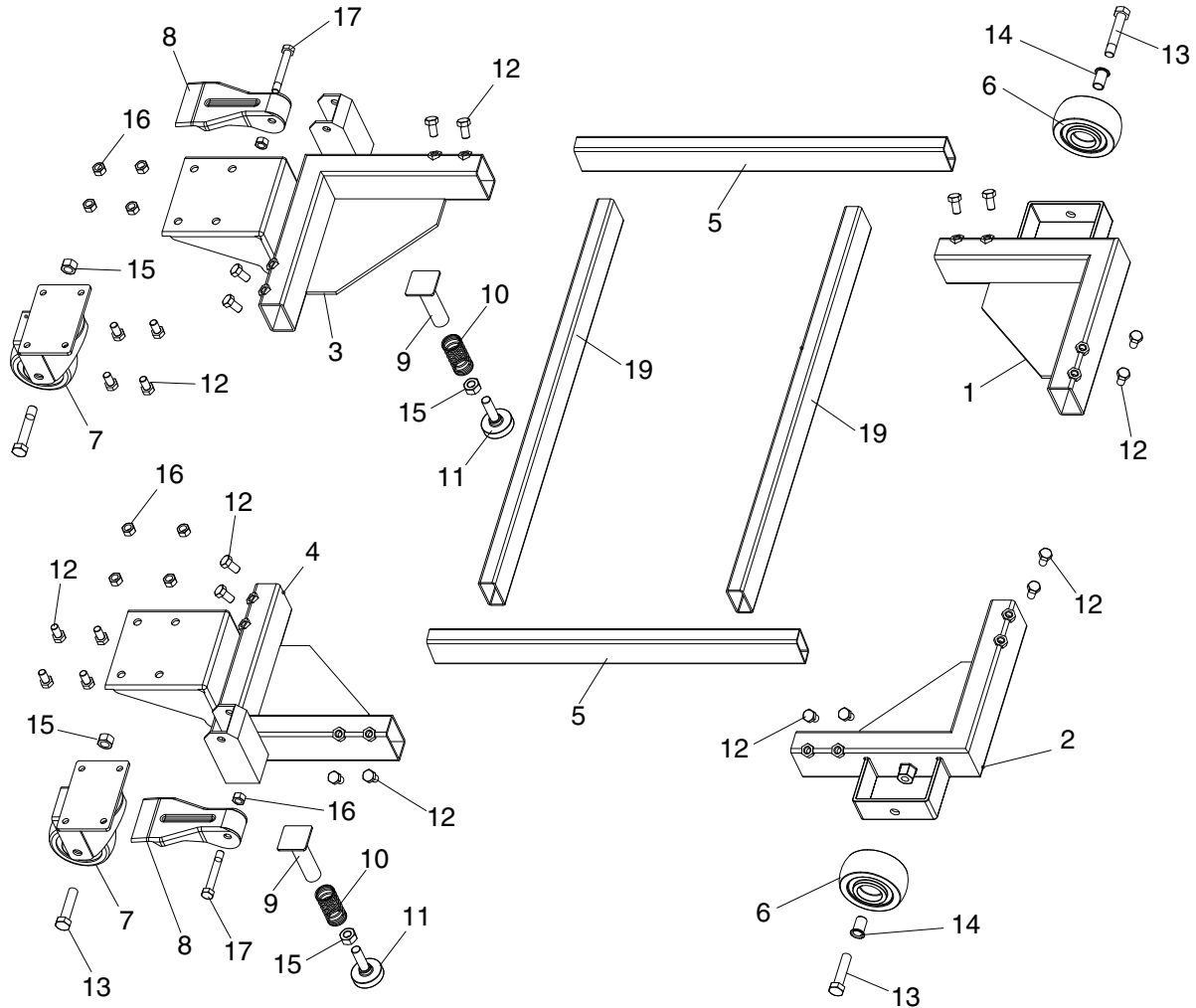

REF	PART #	DESCRIPTION
1	PT28923001	LEFT REAR CORNER BRACKET
2	PT28923002	RIGHT REAR CORNER BRACKET
3	PT28923003	LEFT FRONT CORNER BRACKET
4	PT28923004	RIGHT FRONT CORNER BRACKET
5	PT28923005	RAIL 21"
6	PT28923006	CASTER, 3" FIXED
7	PT28923007	CASTER, 3" SWIVEL
8	PT28923008	FOOT PEDAL
9	PT28923009	FOOT PEDAL PLUNGER

REF	PART #	DESCRIPTION
10	PT28923010	COMPRESSION SPRING 22 X 1.5 X 61
11	PT28923011	ADJUSTABLE FOOT M10-1.5 X 30
12	PT28923012	HEX BOLT M8-1.25 X 16
13	PT28923013	SHOULDER BOLT M10-1.5 X 14, 10 X 55
14	PT28923014	WHEEL BEARING SLEEVE
15	PT28923015	HEX NUT M10-1.5
16	PT28923016	LOCK NUT M8-1.25
17	PT28923017	SHOULDER BOLT M8-1.25 X 8, 8 X 50
19	PT28923019	RAIL 26"

Please Note: We do our best to stock replacement parts whenever possible, but we cannot guarantee that all parts shown here are available for purchase. Call (800) 523-4777 or visit our online parts store at www.grizzly.com to check for availability.



WARRANTY AND RETURNS

Grizzly Industrial, Inc. warrants every product it sells for a period of **1 year** to the original purchaser from the date of purchase. This warranty does not apply to defects due directly or indirectly to misuse, abuse, negligence, accidents, repairs or alterations or lack of maintenance. This is Grizzly's sole written warranty and any and all warranties that may be implied by law, including any merchantability or fitness, for any particular purpose, are hereby limited to the duration of this written warranty. We do not warrant or represent that the merchandise complies with the provisions of any law or acts unless the manufacturer so warrants. In no event shall Grizzly's liability under this warranty exceed the purchase price paid for the product and any legal actions brought against Grizzly shall be tried in the State of Washington, County of Whatcom.

We shall in no event be liable for death, injuries to persons or property or for incidental, contingent, special, or consequential damages arising from the use of our products.

To take advantage of this warranty, contact us by mail or phone and give us all the details. We will then issue you a "Return Number," which must be clearly posted on the outside as well as the inside of the carton. We will not accept any item back without this number. Proof of purchase must accompany the merchandise.

The manufacturers reserve the right to change specifications at any time because they constantly strive to achieve better quality equipment. We make every effort to ensure that our products meet high quality and durability standards and we hope you never need to use this warranty.

Please feel free to write or call us if you have any questions about the machine or the manual.

Thank you again for your business and continued support. We hope to serve you again soon.

