

## Maintenance

Your BOARD BUDDIES® are engineered for dependable service and ease of operation. However with most shop tools, they may need periodic inspection and cleaning.

- **NEVER** lubricate Board Buddy parts. Oil will attract sawdust and foreign material which could jam the mechanism or stain your workpiece.
- **ALWAYS** make sure the jam nuts (5) and the position locking thumbscrews (11) are tight, and the BOARD BUDDIES® are correctly adjusted.

## Troubleshooting

Here are some common solutions for Board Buddy problems:

The Board Buddy does not clamp down on the stock as it should, the pivot arm binds, or the roller tension does not adjust correctly.

1. Refer to the **Safety and Operation** section and re-adjust the Board Buddy correctly.
2. Remove and clean the threads of the adjusting screws and thumbscrews. Replace any stripped adjustment screws and re-adjust.
3. Depress the pivot arm (1) and remove the shoe (7). Clean out any foreign material that is preventing the shoe from sliding inside the housing (2). See **Figure 4**.

4. Replace the shoe if it is broken or worn.

The Board Buddy roller does not lock rotation.

1. Incorrect roller, replace the roller with the correct roller.
2. The roller is broken. Replace the roller with a new one. **DO NOT** rebuild the rollers.

## Parts List

Use **Figure 4** and the parts list to inventory your package. Your new BOARD BUDDIES® are carefully packed. However, if any part is damaged or missing, contact Woodstock International Service and Support at 1-360-734-3482 or send e-mail to: [tech-support@shopfox.biz](mailto:tech-support@shopfox.biz).

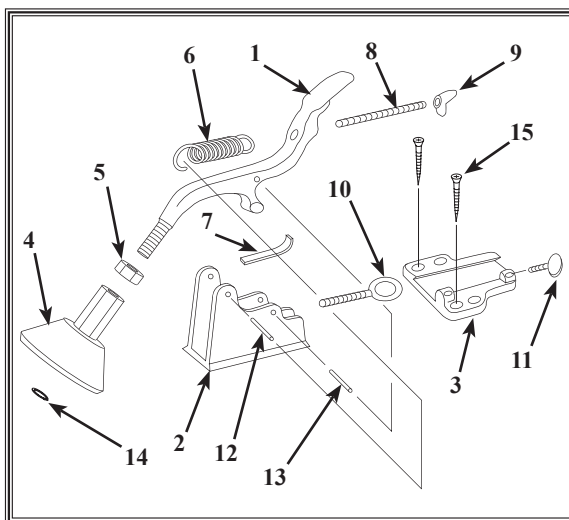

**Figure 4.** Board Buddy Parts.

ITEM PART # DESCRIPTION

ITEM	PART #	DESCRIPTION
1	X1104001	PIVOT ARM
2	X1104002	HOUSING
3	X1104003	MOUNTING BRACKET
4	X1105004	ROLLER (GREEN)
5	X1104005	LOCK NUT ½"-20
6	X1104006	SPRING
7	X1104007	SHOE
8	X1104008	TIE ROD ⅝"-18 x 2-½"
9	X1104009	WING NUT ⅝"-18
10	X1104010	ADJUST ROD ⅝"-18 x 2"
11	X1104011	THUMBSCREW ¼"-20 x ½"
12	XPRP25M	ROLL PIN 5 X 20MM
13	XPRP07M	PIVOT PIN 6 X 20MM
14	XPR16M	EXT RETAINING RING 9MM
15	X1104015	WOOD SCREW ⅜"-12 x 1-⅝"



# BOARD BUDDIES®

## INSTRUCTION MANUAL SHAPER HOLD-DOWN DEVICES (PART # W1105)

### Introduction

**BOARD BUDDIES®** are made from die-cast aluminum and feature non-marring green neoprene rubber wheels. Because the wheels turn in both directions, they function as hold-down rather than anti-kickback devices. You can mount these to fences that are 3" to 3½" high x 1" or wider (see **Figure 1**). Mounting typically requires minor modifications to the shaper fence.

## ⚠ WARNING

Read and understand your machine operators manual, and know the machine limitations.  
**NO ANTI-KICKBACK DEVICE WILL MAKE YOUR MACHINE COMPLETELY SAFE!**

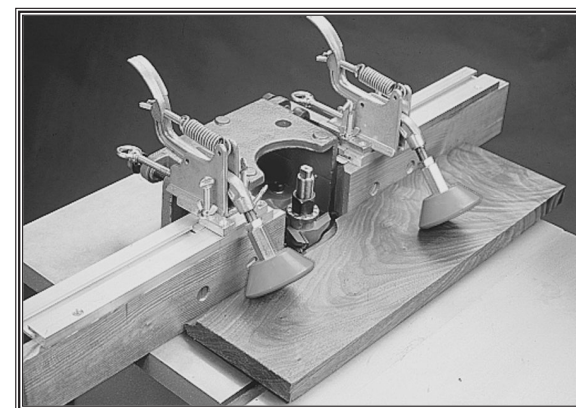

**Figure 1.** Typical Board Buddy application.

## Assembly and Installation

Your BOARD BUDDIES® are partially assembled from the factory; however, some minor assembly and adjustment is required using **Figures 3** and **4** for reference.

The Board Buddy brackets (3) can be installed directly on an auxiliary wood fence (not included) or an optional sliding track (12" part # W1107 or 24" part # W1108 not included). The optional sliding track also mounts to the auxiliary wood fence. See **Figure 2**.



To assemble your BOARD BUDDIES®, see **Figure 4** for item numbers and do these steps:

1. Unplug your machine!
2. Thread the lock nut (5) onto each pivot arm (1).
3. Thread the roller (4) onto each pivot arm no less than 1/2", and tighten the lock nut (5) against the roller nut (4).
4. Slide the housing (2) into the mounting bracket (3) and tighten the thumbscrews (11).

To install your BOARD BUDDIES® see **Figure 1** and **2**, and do these steps:

1. Make an auxiliary wood fence that is approximately 3" tall, 1" thick, and is the length of the machine fence.
2. Mount the auxiliary wood fence to your machine with counter-sunk fasteners.
3. Position the mounting bracket on the auxiliary fence so it does not protrude into the path of the stock. See **Figures 1** and **2**.
4. Position the rollers as close as possible to the shaper spindle, but clear from the blade or cutter used. See **Figure 1**.
5. Position the mounting bracket on the auxiliary fence to maintain clearance for maximum size cutter diameter.
6. Mark the FRONT screw hole locations and drill the pilot holes into the wood fence for the wood screws (REAR holes are for the optional track). See **Figure 2**.
7. Install the mounting bracket with the provided wood screws.

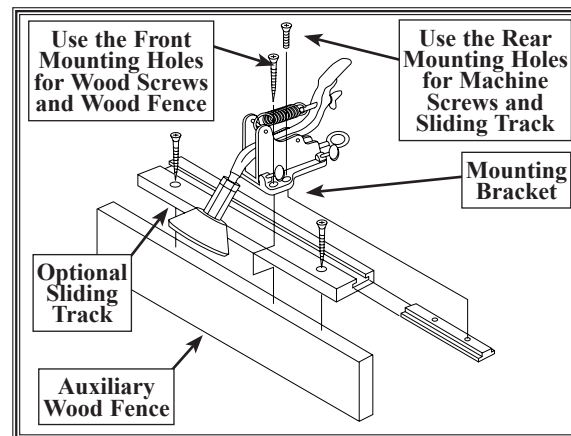
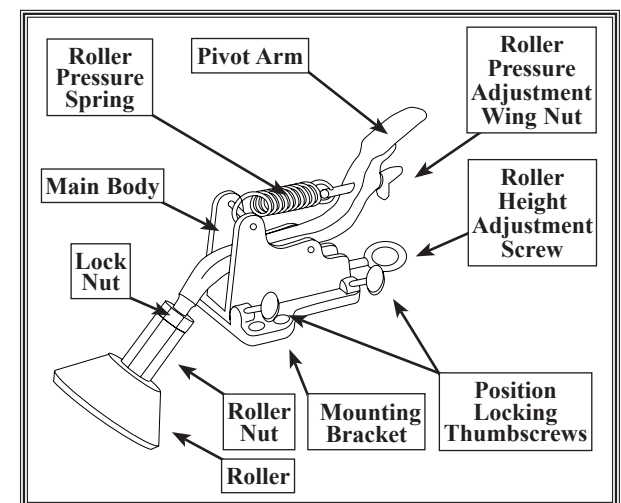

**Figure 2.** Auxiliary wood fence and an optional sliding track.

## Safety and Operation

BOARD BUDDIES® assist stock feeding by maintaining a consistent pressure against the machine table and the fence. See **Figures 1** and **3**.

1. Slide the main body in or out to align the rollers on the stock, and tighten the position locking thumbscrews.
2. Adjust the roller nut, lock nut, and the thumbscrew so the roller height is approximately 1/8" (3mm) less than the stock thickness.
3. Turn the roller pressure adjustment wing nut so the roller applies a firm pressure on the stock, but does not tilt the Board Buddy off of the fence or sliding rack.
4. Make sure BOARD BUDDIES® DO NOT touch the blades or cutters during machine operation.
5. DO NOT adjust or reposition the BOARD BUDDIES® while the machine is running. Wait until the machine comes to a complete stop before making any adjustments.
6. Keep your hands away from all cutting tools.
7. Feed the stock evenly and smoothly.



**Figure 3.** Board Buddy Details.