

SECTION 9: PARTS

Column Breakdown

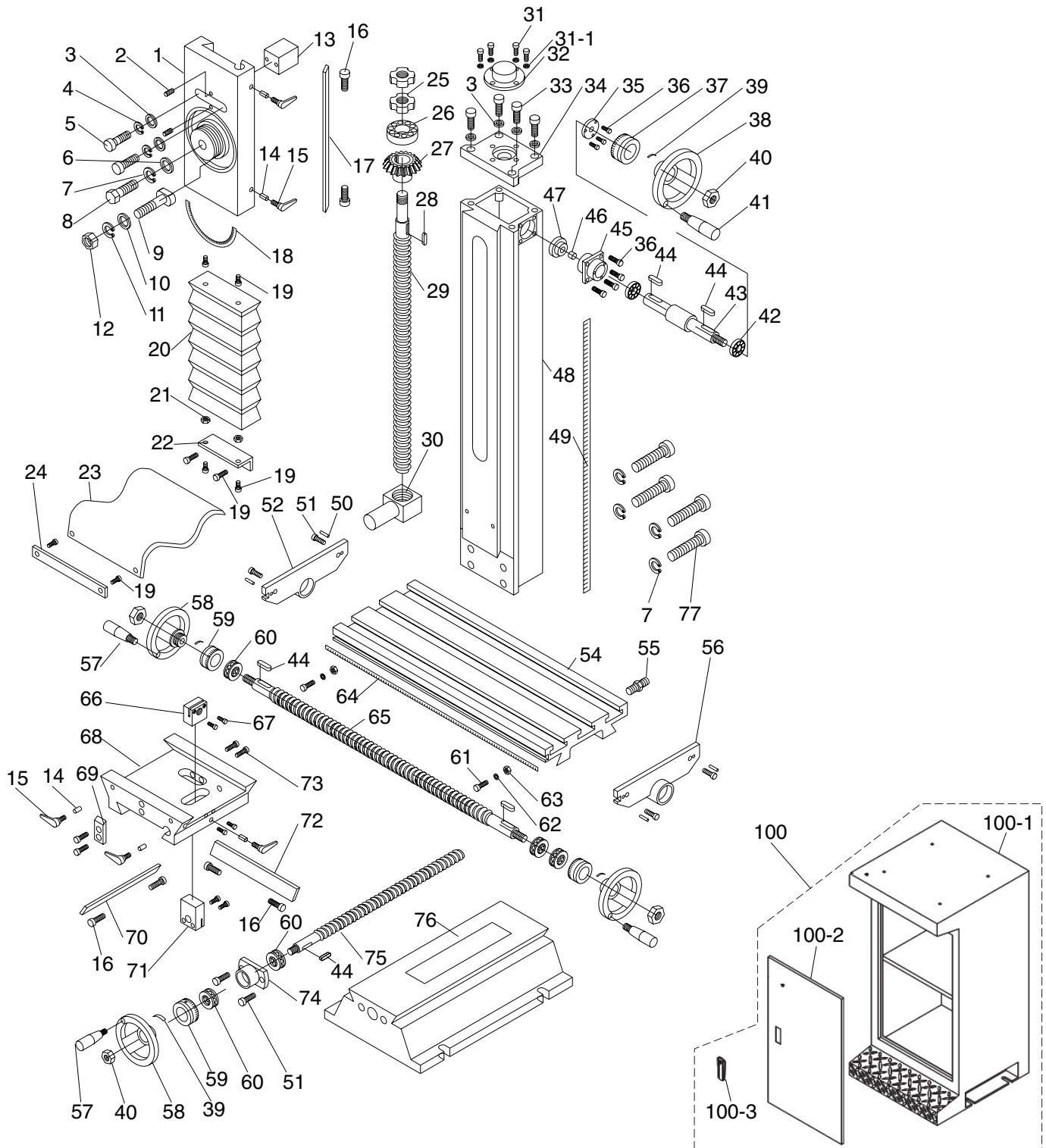

Column Parts List

REF	PART #	DESCRIPTION
1	P0704001	Z-AXIS SLIDE
2	P0704002	SET SCREW M6-1 X 16
3	P0704003	FLAT WASHER 8MM
4	P0704004	LOCK WASHER 8MM
5	P0704005	CAP SCREW M8-1.25 X 25
6	P0704006	FLAT WASHER 12MM
7	P0704007	LOCK WASHER 12MM
8	P0704008	CAP SCREW M12-1.75 X 40
9	P0704009	T-BOLT M10-1.5
10	P0704010	FLAT WASHER 10MM
11	P0704011	LOCK WASHER 10MM
12	P0704012	HEX NUT M10-1.5
13	P0704013	SLIDE ALIGNMENT BLOCK
14	P0704014	BRASS PIN
15	P0704015	ADJUSTABLE HANDLE M6-1 X 16
16	P0704016	GIB ADJUSTMENT SCREW
17	P0704017	Z-AXIS GIB
18	P0704018	HEADSTOCK ANGLE SCALE
19	P0704019	CAP SCREW M5-.8 X 10
20	P0704020	Z-AXIS WAY COVER
21	P0704021	HEX NUT M5-.8
22	P0704022	Z-AXIS WAY COVER BRACKET
23	P0704023	Y-AXIS WAY COVER
24	P0704024	Y-AXIS WAY COVER BRACKET
25	P0704025	LEADSCREW LOCK NUT M16-1.5
26	P0704026	THRUST BEARING 51203
27	P0704027	RING GEAR
28	P0704028	KEY 4 X 4 X 16
29	P0704029	Z-AXIS LEADSCREW
30	P0704030	Z-AXIS LEADSCREW NUT
31	P0704031	CAP SCREW M5-.8 X 12
31-1	P0704031-1	FLAT WASHER 5MM
32	P0704032	BEARING COVER
33	P0704033	CAP SCREW M8-1.25 X 20
34	P0704034	COLUMN TOP PLATE
35	P0704035	COLLAR FLANGE
36	P0704036	CAP SCREW M5-.8 X 12
37	P0704037	Z-AXIS GRADUATED DIAL
38	P0704038	Z-AXIS HANDWHEEL
39	P0704039	HANDWHEEL CURVED PLATE SPRING
40	P0704040	HEX NUT M8-1.25

REF	PART #	DESCRIPTION
41	P0704041	Z-AXIS HANDWHEEL HANDLE M6-1 X 10
42	P0704042	BALL BEARING 6001ZZ
43	P0704043	Z-AXIS HANDWHEEL SHAFT
44	P0704044	KEY 4 X 4 X 12
45	P0704045	PILLOW BLOCK
46	P0704046	SPACER
47	P0704047	PINION GEAR
48	P0704048	COLUMN
49	P0704049	Z-AXIS SCALE
50	P0704050	THREADED SLEEVE M6-1 X 16
51	P0704051	CAP SCREW M6-1 X 14
52	P0704052	X-AXIS LEADSCREW BRACKET (LH)
54	P0704054	TABLE
55	P0704055	COOLANT HOSE FITTING
56	P0704056	X-AXIS LEADSCREW BRACKET (RH)
57	P0704057	TABLE HANDWHEEL HANDLE M6-1 X 10
58	P0704058	TABLE HANDWHEEL
59	P0704059	TABLE GRADUATED DIAL
60	P0704060	THRUST BEARING 51200
61	P0704061	CAP SCREW M6-1 X 10
62	P0704062	LIMIT STOP
63	P0704063	T-NUT M6-1
64	P0704064	X-AXIS SCALE
65	P0704065	X-AXIS LEADSCREW
66	P0704066	X-AXIS LEADSCREW NUT
67	P0704067	CAP SCREW M4-.7 X 20
68	P0704068	SADDLE
69	P0704069	TABLE STOP BLOCK
70	P0704070	Y-AXIS GIB
71	P0704071	Y-AXIS LEADSCREW NUT
72	P0704072	X-AXIS GIB
73	P0704073	CAP SCREW M6-1 X 25
74	P0704074	X-AXIS BEARING HOUSING
75	P0704075	Y-AXIS LEADSCREW
76	P0704076	BASE
77	P0704077	CAP SCREW M12-1.75 X 90
100	P0704100	STAND ASSEMBLY
100-1	P0704100-1	STAND CABINET
100-2	P0704100-2	STAND DOOR
100-3	P0704100-3	STAND DOOR LATCH



Electrical Box Breakdown & Parts List

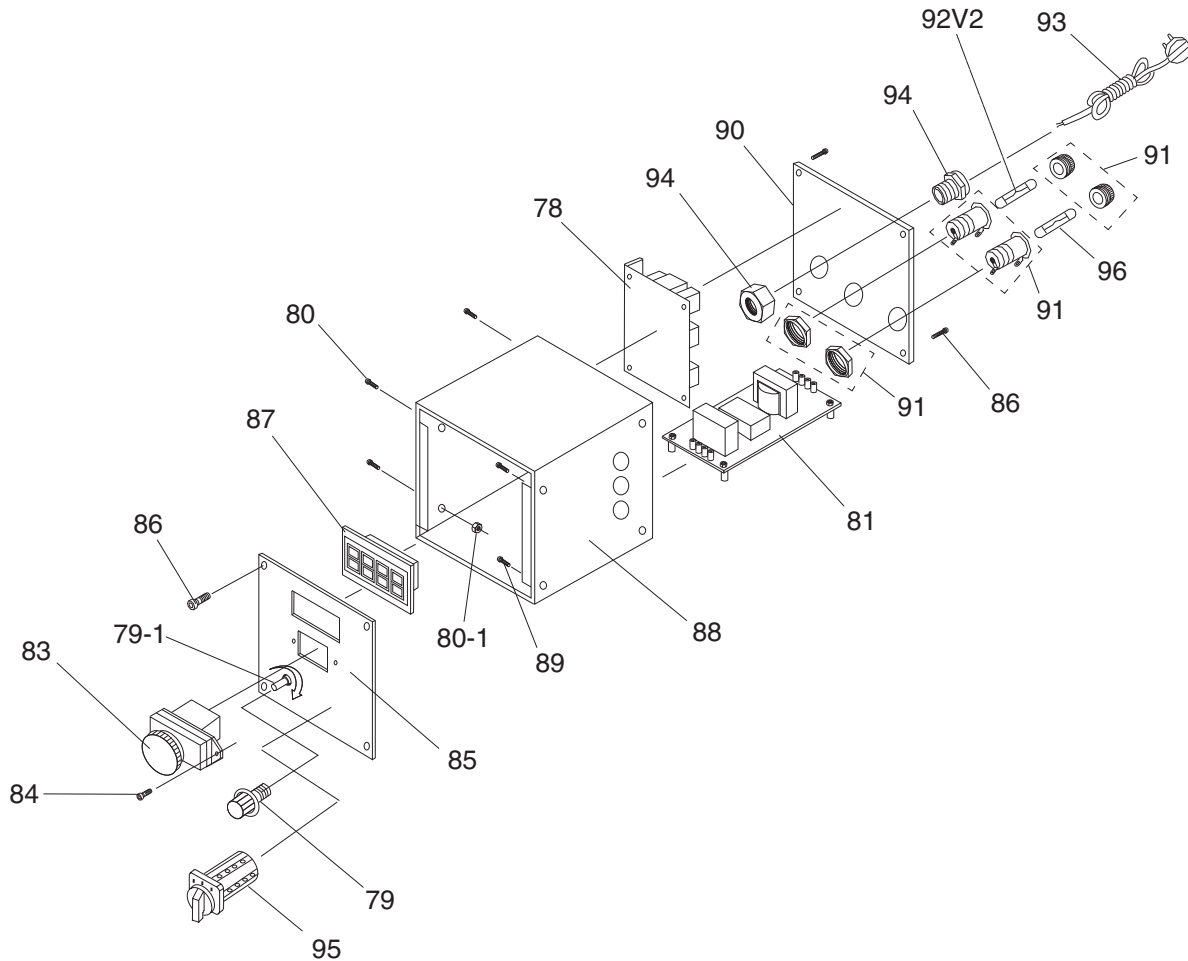

REF	PART #	DESCRIPTION
78	P0704078	CIRCUIT BOARD
79	P0704079	SPINDLE SPEED KNOB WX14-12
79-1	P0704079-1	SPINDLE SPEED POTENTIOMETER
80	P0704080	CAP SCREW M3-.5 X 16
80-1	P0704080-1	HEX NUT M3-.5
81	P0704081	CIRCUIT BOARD CESX 1101-28
83	P0704083	ON/OFF SWITCH KEDU KJD-178/120V
84	P0704084	CAP SCREW M4-.7 X 10
85	P0704085	CONTROL PANEL PLATE
86	P0704086	CAP SCREW M4-.7 X 6

REF	PART #	DESCRIPTION
87	P0704087	RPM DIGITAL DISPLAY ZD-SX-THL
88	P0704088	ELECTRICAL BOX
89	P0704089	CAP SCREW M5-.8 X 8
90	P0704090	ELECTRICAL BOX REAR COVER
91	P0704091	FUSE HOLDER
92V2	P0704092V2	FUSE F15AL250V 15A V2.01.10
93	P0704093	POWER CORD 16G 3W 72" 5-15
94	P0704094	STRAIN RELIEF M20 X 1.5 TYPE-3
95	P0704095	FWD/REV SWITCH KEDU EN61058
96	P0704096	FUSE F10AL250V 10A



Headstock Breakdown

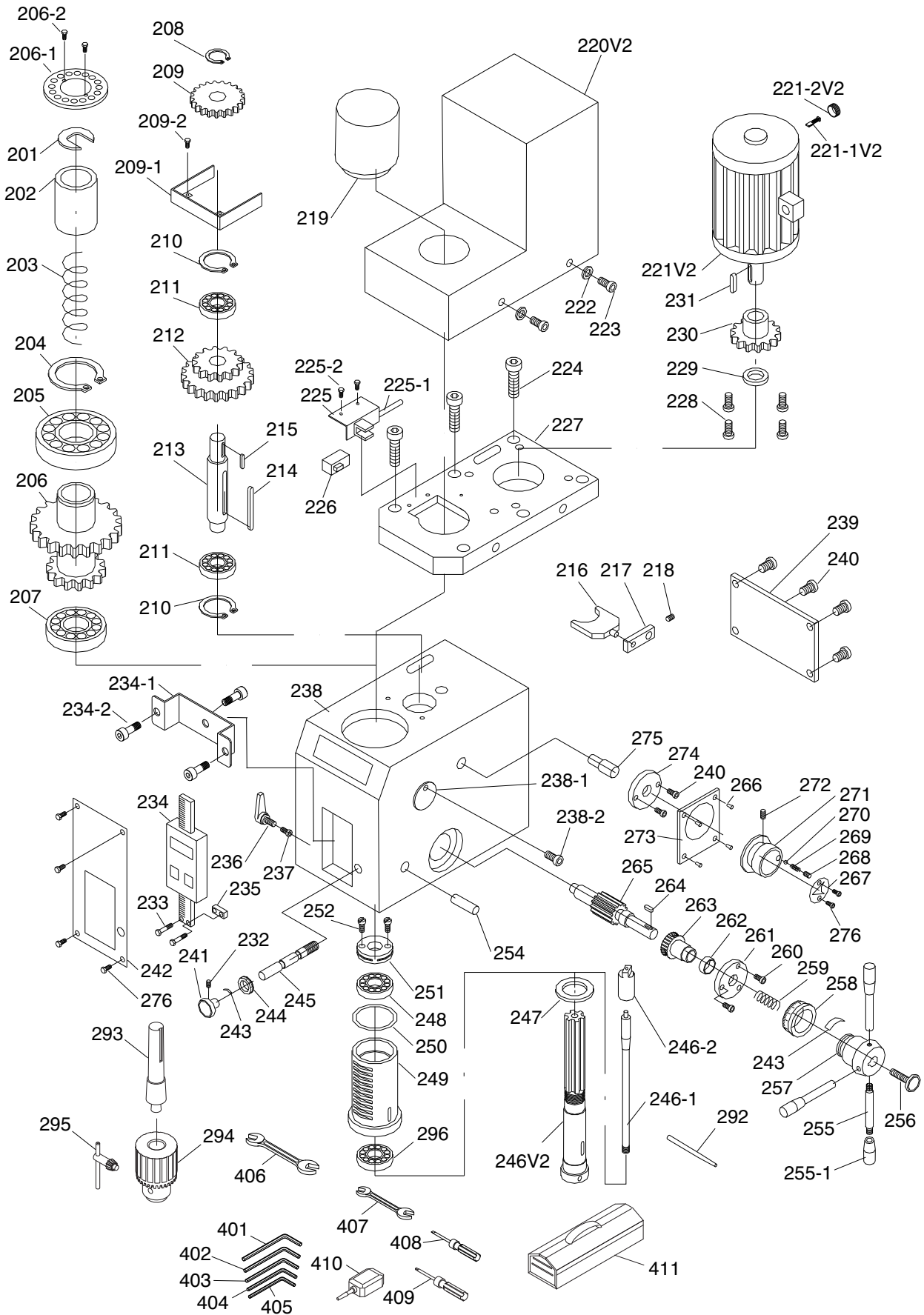

Headstock Parts List

REF	PART #	DESCRIPTION
201	P0704201	QUILL RETAINING CLIP
202	P0704202	BUSHING
203	P0704203	COMPRESSION SPRING
204	P0704204	EXT RETAINING RING 45MM
205	P0704205	BALL BEARING 6209ZZ
206	P0704206	COMBO GEAR 60/70T
206-1	P0704206-1	SPINDLE RING 16MM
206-2	P0704206-2	CAP SCREW M3-.5 X 8
207	P0704207	BALL BEARING 6007-2RS
208	P0704208	EXT RETAINING RING 15MM
209	P0704209	GEAR 37T 15MM ID BORE
209-1	P0704209-1	GEAR GUARD
209-2	P0704209-2	CAP SCREW M3-.5 X 6
210	P0704210	EXT RETAINING RING 32MM
211	P0704211	BALL BEARING 6002ZZ
212	P0704212	COMBO GEAR 42/62T
213	P0704213	SHAFT
214	P0704214	KEY 5 X 5 X 50
215	P0704215	KEY 5 X 5 X 12
216	P0704216	FORK
217	P0704217	FORK ARM
218	P0704218	SET SCREW M5-.8 X 8
219	P0704219	DRAWBAR CAP
220	P0704220	MOTOR COVER V1
221V3	P0704221V3	MOTOR 1HP 110V (14MM SHAFT) V3.04.13
221-1V2	P0704221-1V2	CARBON BRUSH 1-PC V2.11.12
221-2V2	P0704221-2V2	CARBON BRUSH CAP 1-PC V2.11.12
222	P0704222	FLAT WASHER 4MM
223	P0704223	CAP SCREW M4-.7 X 8
224	P0704224	CAP SCREW M6-1 X 14
225	P0704225	SENSOR BRACKET
225-1	P0704225-1	SENSOR CORD
225-2	P0704225-2	CAP SCREW M3-.5 X 6
226	P0704226	RPM SENSOR
227	P0704227	MOTOR PLATE
228	P0704228	CAP SCREW M5-.8 X 12
229V2	P0704229V2	EXT RETAINING RING 14MM
230V2	P0704230V2	GEAR 20T (ID 14MM) V2.04.13
231V2	P0704231V2	KEY 5 X 5 X 15
232	P0704232	SET SCREW M5-.8 X 6
233	P0704233	CAP SCREW M3-.5 X 6
234	P0704234	DIGITAL READOUT UNIT
234-1	P0704234-1	DIGITAL READOUT BRACKET
234-2	P0704234-2	CAP SCREW M4-.7 X 10
235	P0704235	BASE BLOCK
236	P0704236	QUILL LOCKING LEVER
237	P0704237	BRASS PIN
238	P0704238	MILL HEAD CASTING

REF	PART #	DESCRIPTION
238-1	P0704238-1	ROUND INSPECTION COVER
238-2	P0704238-2	CAP SCREW M4-.7 X 8
239	P0704239	COVER PLATE
240	P0704240	CAP SCREW M4-.7 X 8
241	P0704241	FINE FEED KNOB
242	P0704242	FRONT COVER
243	P0704243	HANDWHEEL CURVED PLATE SPRING
244	P0704244	FINE FEED COLLAR
245	P0704245	WORM SHAFT
246V2	P0704246	SPINDLE V2.08.11
246-1	P0704246-1	DRAWBAR
246-2	P0704246-2	RETAINER CUP
247	P0704247	SPINDLE RING
248	P0704248	TAPERED ROLLER BEARING 32005
249	P0704249	QUILL SLEEVE
250	P0704250	RUBBER RING
251	P0704251	ADJUSTER NUT
252	P0704252	ADJUSTER NUT SCREW
254	P0704254	PIN 6 X 30
255	P0704255	HANDLE
255-1	P0704255-1	HANDLE GRIP
256	P0704256	SELECTOR KNOB
257	P0704257	DOWNFEED HUB
258	P0704258	DOWNFEED COLLAR
259	P0704259	COMPRESSION SPRING
260	P0704260	CAP SCREW M4-.7 X 40
261	P0704261	DOWNFEED FLANGE
262	P0704262	SPACER
263	P0704263	WORM GEAR
264	P0704264	KEY 4 X 4 X 12
265	P0704265	GEAR SHAFT
266	P0704266	RIVET
267	P0704267	HIGH/LOW ARROW PLATE
268	P0704268	SET SCREW M8-1.25 X 8
269	P0704269	COMPRESSION SPRING
270	P0704270	STEEL BALL 6.5MM
271	P0704271	SPEED SELECTOR KNOB
272	P0704272	SET SCREW M5-.8 X 16
273	P0704273	SPEED KNOB PLATE
274	P0704274	FORK SHAFT FLANGE
275	P0704275	FORK SHAFT
276	P0704276	CAP SCREW M3-.5 X 6
292	P0704292	SPINDLE PIN
293	P0704293	DRILL CHUCK ARBOR R8 X B16
294	P0704294	DRILL CHUCK B16 3-16MM
295	P0704295	CHUCK KEY FOR B16 16MM CHUCK
296	P0704296	TAPERED ROLLER BEARING 32007



Chip Guard Breakdown & Parts List

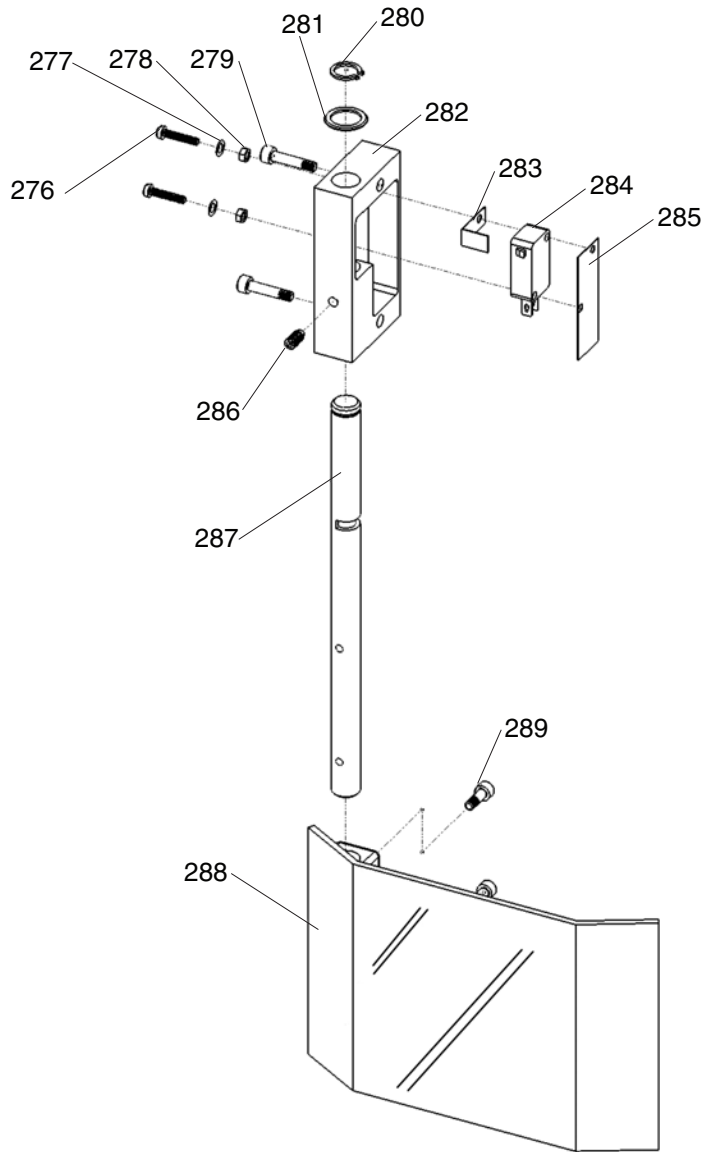

REF	PART #	DESCRIPTION
277	P0704277	FLAT WASHER 3MM
278	P0704278	HEX NUT M3-.5
279	P0704279	CAP SCREW M4-.7 X 20
280	P0704280	EXT RETAINING RING 12MM
281	P0704281	WAVY WASHER 20MM
282	P0704282	GUARD MOUNTING BLOCK
283	P0704283	COPPER SPACER

REF	PART #	DESCRIPTION
284	P0704284	GUARD LIMIT SWITCH
285	P0704285	PROTECTIVE PAPER
286	P0704286	SET SCREW M5-.8 X 10
287	P0704287	CHIP GUARD POST
288	P0704288	CHIP GUARD
289	P0704289	CAP SCREW M4-.7 X 18



Labels Breakdown & Parts List



REF	PART #	DESCRIPTION
301	P0704301	READ MANUAL LABEL
302	P0704302	SAFETY GLASSES LABEL
303	P0704303	MACHINE ID LABEL
304	P0704304	HIGH/LOW SPEED LABEL
305	P0704305	PUTTY TOUCH-UP PAINT

REF	PART #	DESCRIPTION
306	P0704306	MODEL NUMBER LABEL
307	P0704307	GREEN TOUCH-UP PAINT
308	P0704308	CUTTER WARNING LABEL
309	P0704309	ENTANGLEMENT LABEL
310	P0704310	AVOID OVERHEATING NOTICE

!WARNING

Safety labels warn about machine hazards and ways to prevent injury. The owner of this machine **MUST** maintain the original location and readability of the labels on the machine. If any label is removed or becomes unreadable, **REPLACE** that label before using the machine again. Contact Grizzly at (800) 523-4777 or www.grizzly.com to order new labels.

