

SECTION 9: PARTS

We do our best to stock replacement parts when possible, but we cannot guarantee that all parts shown are available for purchase. Call (800) 523-4777 or visit www.grizzly.com/parts to check for availability.

Tables, Fence & Cutterhead

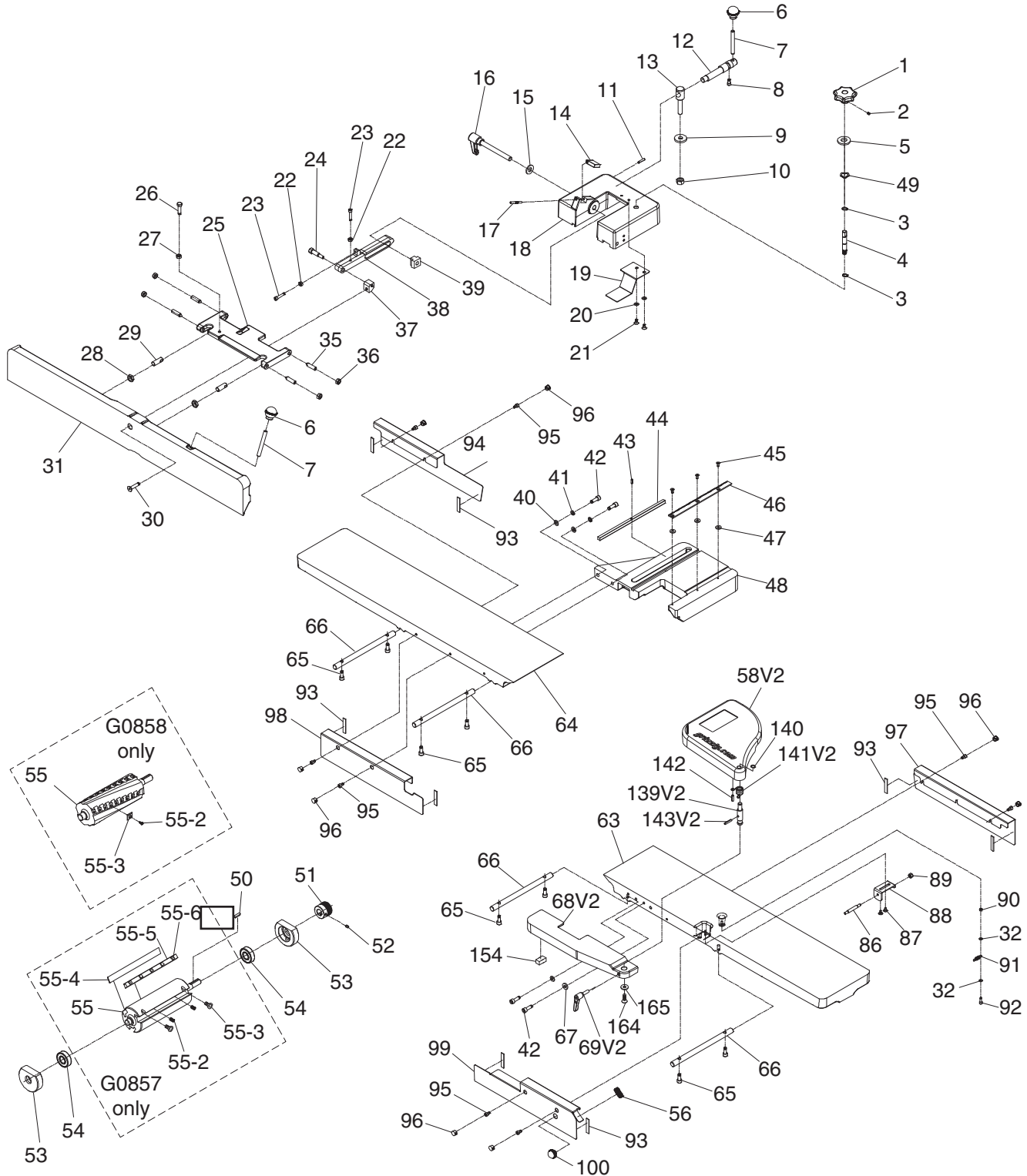

Base, Stand & Motor

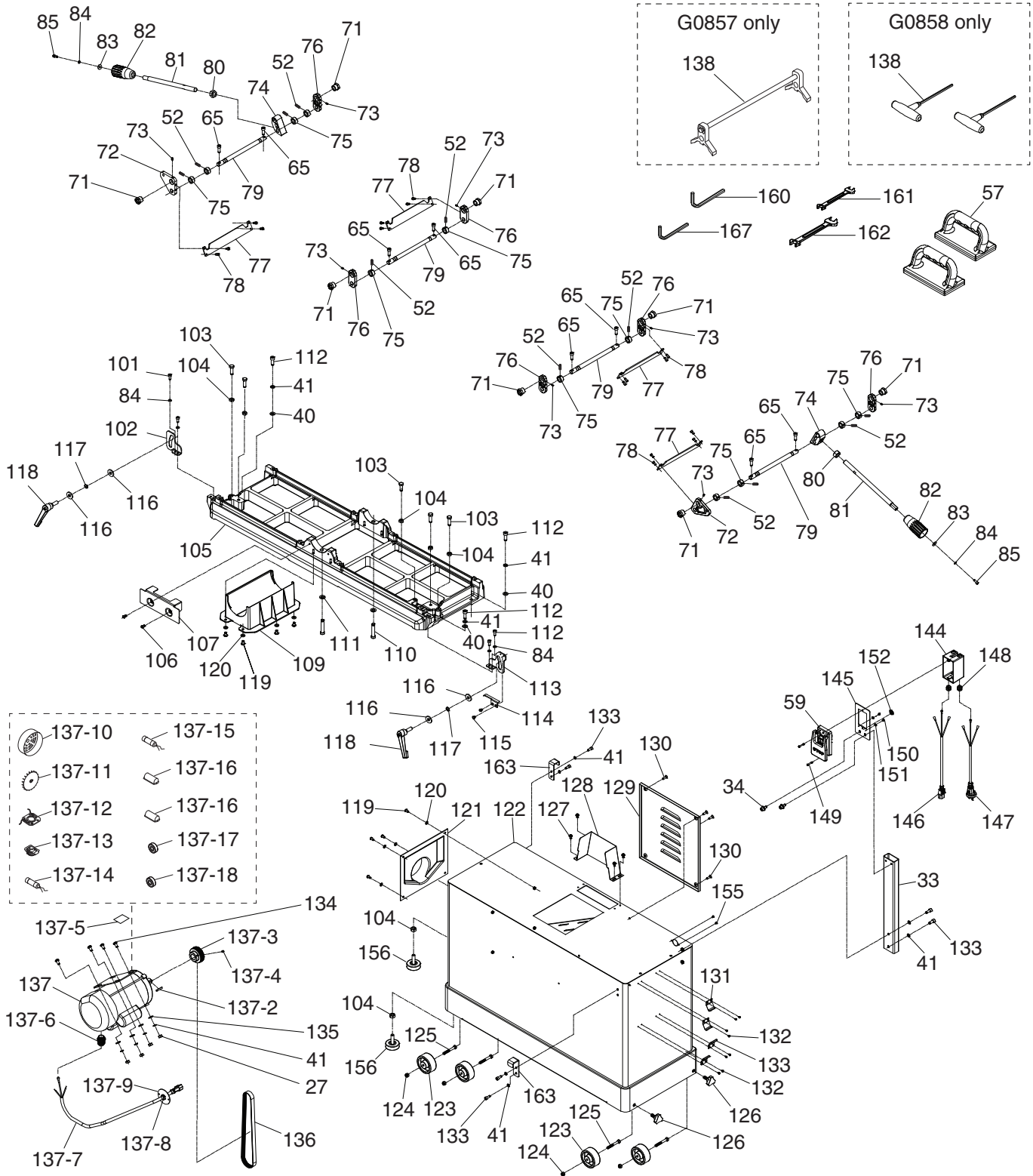

Parts List

REF	PART #	DESCRIPTION	REF	PART #	DESCRIPTION
1	P0857001	KNOB 12ID, M6-1 SET SCREW THREADS	55-3	P0857055-3	FLAT HD CAP SCR M5-.8 X 12 (G0857)
2	P0857002	SET SCREW M6-1 X 6	55-4	P0857055-4	KNIFE 8 X 3/4 X 1/8 HSS (G0857)
3	P0857003	EXT RETAINING RING 12MM	55-5	P0857055-5	KNIFE GIB (G0857)
4	P0857004	GEAR SHAFT 10T, 11 X 78.5MM	55-6	P0857055-6	KNIFE GIB BOLT 1/4-28 X 1/4 (G0857)
5	P0857005	FLAT WASHER 12MM	55	P0858055	8" HELICAL CUTTERHEAD (G0858)
6	P0857006	KNOB 3/8-16, D1-5/16, BALL	55-2	P0858055-2	FLAT HD TORX SCR T-25 10-32 X 1/2 (G0858)
7	P0857007	STUD-DE 3/8-16 X 3-1/8, 3/8	55-3	P0858055-3	CARBIDE INSERT 15 X 15 X 2.5MM (G0858)
8	P0857008	CAP SCREW 1/4-20 X 1/2	56	P0857056	DEPTH SCALE LABEL
9	P0857009	FENDER WASHER 1/2	57	P0857057	PUSH BLOCKS
10	P0857010	LOCK NUT 1/2-12	58V2	P0857058V2	CUTTERHEAD GUARD V2.07.19
11	P0857011	ROLL PIN 4 X 25	59	P0857059	PADDLE MAG SWITCH KJD17B-230V-S
12	P0857012	ECCENTRIC SHAFT 3/8-16, 5-1/4L	63	P0857063	INFEEED TABLE
13	P0857013	CAMLOCK STUD 1/2-12 X 1-1/2, 3-1/2L	64	P0857064	OUTFEED TABLE
14	P0857014	STOP BLOCK	65	P0857065	CAP SCREW M8-1.25 X 25
15	P0857015	FLAT WASHER 1/2	66	P0857066	TABLE SHAFT 9-5/8L
16	P0857016	ADJ HANDLE 3L, 1/2-12 X 1-3/8	67	P0857067	FLAT WASHER 8MM
17	P0857017	DOWEL PIN 5 X 50	68V2	P0857068V2	RABBETING TABLE V2.07.19
18	P0857018	FENCE CARRIAGE	69V2	P0857069V2	CUTTERHEAD GUARD LOCK HANDLE V2.07.19
19	P0857019	SAFETY PLATE	71	P0857071	ECCENTRIC BUSHING
20	P0857020	FLAT WASHER 1/4	72	P0857072	BUSHING PLATE (3-HOLE)
21	P0857021	FLAT HD SCR 1/4-20 X 1/2	73	P0857073	SET SCREW M5-.8 X 8
22	P0857022	HEX NUT 1/4-20	74	P0857074	ELEVATION BRACKET
23	P0857023	CAP SCREW 1/4-20 X 1-1/4	75	P0857075	BUSHING
24	P0857024	SHOULDER BOLT 5/16-18 X 11/16, 3/8 X 1	76	P0857076	BUSHING PLATE (2-HOLE)
25	P0857025	FENCE SWIVEL BASE	77	P0857077	ELEVATION PLATE
26	P0857026	HEX BOLT 5/16-18 X 1-1/4	78	P0857078	CAP SCREW M5-.8 X 10
27	P0857027	HEX NUT 5/16-18	79	P0857079	ELEVATION SHAFT 10-1/4L
28	P0857028	HEX NUT 1/2-20 THIN	80	P0857080	HEX NUT M16-2
29	P0857029	STUD-SE 1/2-20 X 1-3/8, 11/16	81	P0857081	SHAFT INT THR M6-1, EXT THR M16-2
30	P0857030	FLAT HD CAP SCR 5/16-18 X 1-1/2	82	P0857082	LEVER KNOB
31	P0857031	FENCE	83	P0857083	FLAT WASHER 6MM
32	P0857032	FLAT WASHER 5MM	84	P0857084	LOCK WASHER 6MM
33	P0857033	SWITCH PEDESTAL	85	P0857085	CAP SCREW M6-1 X 16
34	P0857034	CAP SCREW M8-1.25 X 20 W/WASHERS	86	P0857086	STANDOFF-RND MM 1/4-20 X 2-3/8, 1/2
35	P0857035	SET SCR 3/8-16 X 1-1/2 CONE-PT, SLOTTED	87	P0857087	SHOULDER FLANGE SCR M5-.8, 6 X 3.3
36	P0857036	HEX NUT 3/8-16 THIN	88	P0857088	POSITION PLATE
37	P0857037	FENCE BLOCK	89	P0857089	LOCK NUT 1/4-20
38	P0857038	FENCE LINK	90	P0857090	HEX NUT M5-.8
39	P0857039	T-NUT 1/2-12	91	P0857091	EXTENSION SPRING
40	P0857040	FLAT WASHER 8MM	92	P0857092	CAP SCREW M5-.8 X 15
41	P0857041	LOCK WASHER 8MM	93	P0857093	FOAM PAD
42	P0857042	CAP SCREW M8-1.25 X 25	94	P0857094	REAR COVER (LEFT)
43	P0857043	ROLL PIN 4 X 20	95	P0857095	CAP SCREW M6-1 X 10
44	P0857044	KEY 9.5 X 9.5 X 268	96	P0857096	PLUG (PLASTIC)
45	P0857045	FLAT HD CAP SCR M5-.8 X 12	97	P0857097	REAR COVER (RIGHT)
46	P0857046	FENCE GUIDE	98	P0857098	FRONT COVER (LEFT)
47	P0857047	FLAT WASHER 1/4	99	P0857099	FRONT COVER (RIGHT)
48	P0857048	FENCE BASE	100	P0857100	KNOB 1/4-20, D1, BALL
49	P0857049	WAVY WASHER 19MM	101	P0857101	CAP SCREW M6-1 X 15
50	P0857050	KEY 5 X 5 X 22	102	P0857102	OUTFEED TABLE LOCK PLATE
51	P0857051	CUTTERHEAD PULLEY	103	P0857103	HEX BOLT M8-1.25 X 30
52	P0857052	SET SCREW M6-1 X 8	104	P0857104	HEX NUT M8-1.25
53	P0857053	BEARING BLOCK	105	P0857105	TABLE BASE
54	P0857054	BALL BEARING 6204-2NSE	106	P0857106	FLAT HD CAP SCR M6-1 X 10
55	P0857055	CUTTERHEAD 8" 4-KNIFE (G0857)	107	P0857107	CUTTERHEAD FRONT COVER
55-2	P0857055-2	COMPRESSION SPRING (G0857)	109	P0857109	DUST COVER



Parts List (Cont.)

REF	PART #	DESCRIPTION
110	P0857110	CAP SCREW 3/8-24 X 2
111	P0857111	LOCK WASHER 3/8
112	P0857112	HEX BOLT M8-1.25 X 25
113	P0857113	INFEED TABLE LOCK PLATE
114	P0857114	SCALE POINTER
115	P0857115	BUTTON HD CAP SCREW M5-.8 X 6
116	P0857116	FLAT WASHER 10MM
117	P0857117	WAVY WASHER 10MM
118	P0857118	ADJ HANDLE 93L, M10-1.5 X 25
119	P0857119	PHLP HD SCR M6-1 X 12
120	P0857120	FLAT WASHER 6MM
121	P0857121	DUST PORT 4"
122	P0857122	CABINET STAND
123	P0857123	WHEEL
124	P0857124	LOCK NUT M8-1.25
125	P0857125	WHEEL AXLE M8-1.25 X 30, 60L
126	P0857126	KNOB BOLT 3-LOBE, M10-1.5 X 22, D40
127	P0857127	PHLP HD SCR M6-1 X 10 W/WASHER
128	P0857128	BELT COVER
129	P0857129	REAR ACCESS PANEL
130	P0857130	PHLP HD SCR M6-1 X 20
131	P0857131	PUSH BLOCK BRACKET
132	P0857132	PHLP HD SCR M4-.7 X 8
133	P0857133	CAP SCREW M8-1.25 X 20
134	P0857134	CARRIAGE BOLT 5/16-18 X 3/4
135	P0857135	FLAT WASHER 8MM
136	P0857136	POLY V-BELT 300J-7 30"
137	P0857137	MOTOR 3HP 230V 1-PH
137-2	P0857137-2	KEY 5 X 5 X 30
137-3	P0857137-3	MOTOR PULLEY
137-4	P0857137-4	SET SCREW M6-1 X 8
137-5	P0857137-5	MOTOR LABEL
137-6	P0857137-6	STRAIN RELIEF TYPE-3 PG13.5
137-7	P0857137-7	MOTOR CORD 14G 3W 32"
137-8	P0857137-8	STRAIN RELIEF TYPE-1 3/4"
137-9	P0857137-9	BACKING BOARD

REF	PART #	DESCRIPTION
137-10	P0857137-10	MOTOR FAN COVER
137-11	P0857137-11	MOTOR FAN
137-12	P0857137-12	CONTACT PLATE
137-13	P0857137-13	CENTRIFUGAL SWITCH
137-14	P0857137-14	S CAPACITOR 400M 125V 1-1/2 X 3-1/2
137-15	P0857137-15	R CAPACITOR 70M 250V 1-1/2 X 3-1/2
137-16	P0857137-16	CAPACITOR COVER
137-17	P0857137-17	BALL BEARING 6205-ZZ (FRONT)
137-18	P0857137-18	BALL BEARING 6203-ZZ (REAR)
138	P0857138	KNIFE-SETTING JIG (G0857)
138	P0858138	TORX DRIVER T-25 (G0858)
139V2	P0857139V2	GUARD PIVOT SHAFT V2.07.19
140	P0857140	EXT RETAINING RING 11MM
141V2	P0857141V2	TORSION SPRING V2.07.19
142	P0857142	ROLL PIN 6 X 28
143V2	P0857143V2	ROLL PIN 5 X 26 V2.07.19
144	P0857144	SWITCH BOX
145	P0857145	SWITCH PLATE
146	P0857146	SWITCH CORD 14G 3W 20"
147	P0857147	POWER CORD 14G 3W 10' 6-20P
148	P0857148	STRAIN RELIEF TYPE-1 5/8"
149	P0857149	PHLP HD SCR M4-.7 X 25
150	P0857150	PHLP HD SCR M4-.7 X 6
151	P0857151	EXT TOOTH WASHER 4MM
152	P0857152	GROUND LABEL
154	P0857154	FOAM PAD 30 X 30 X 22
155	P0857155	TAP SCREW M6 X 8
156	P0857156	ADJUSTABLE FOOT M8-1.25
160	P0857160	HEX WRENCH 6MM
161	P0857161	WRENCH 8 X 10MM OPEN-ENDS
162	P0857162	WRENCH 11 X 13MM OPEN-ENDS
163	P0857163	LIFTING HOOK
164	P0857164	BUTTON HD CAP SCR M6-1 X 12
165	P0857165	CUTTERHEAD GUARD WASHER 6.7 X 19 X 2
167	P0857167	HEX WRENCH 4MM



Labels & Cosmetics

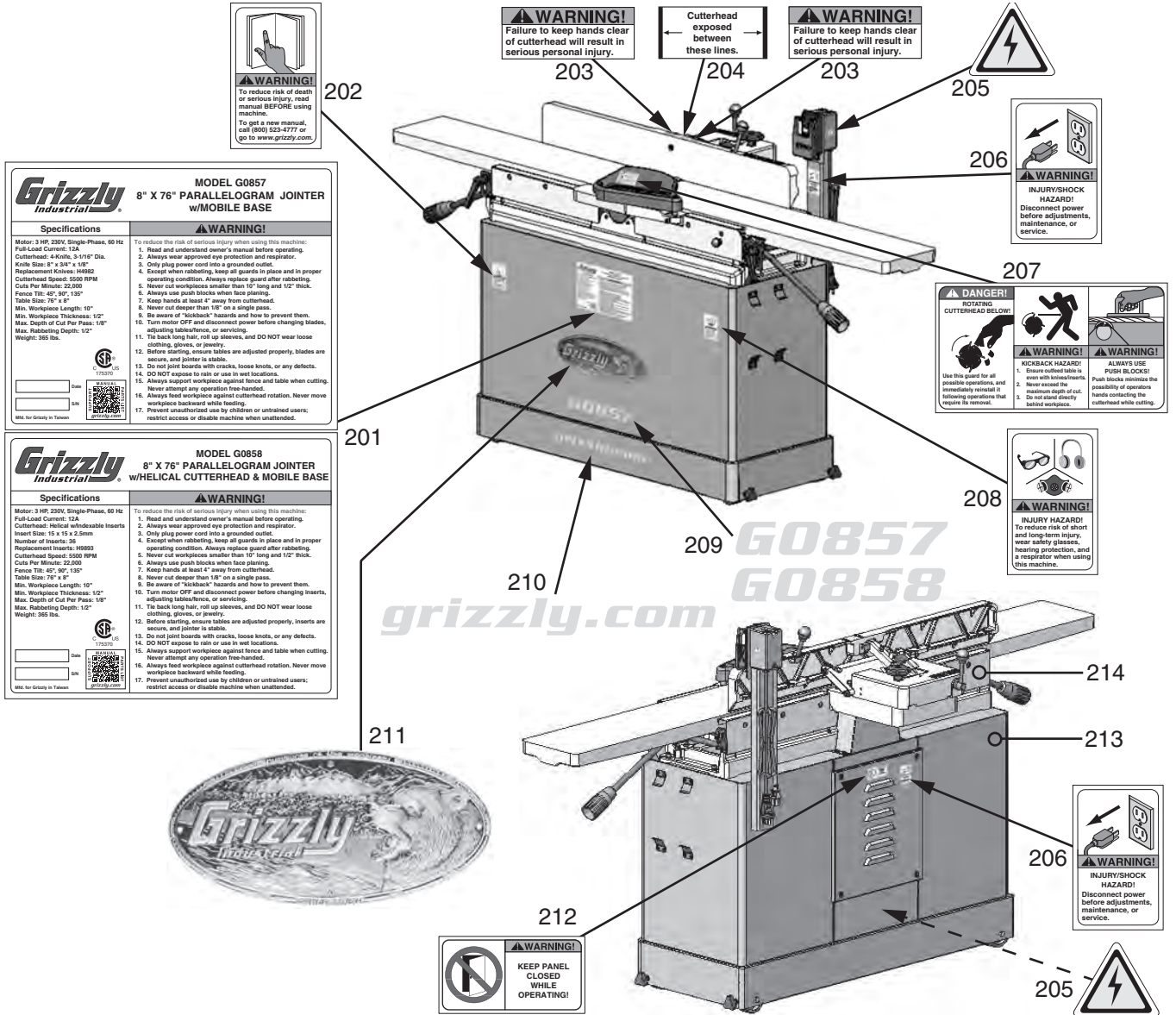

REF	PART #	DESCRIPTION
201	P0857201	MACHINE ID LABEL (G0857)
201	P0858201	MACHINE ID LABEL (G0858)
202	P0857202	READ MANUAL LABEL
203	P0857203	CUTTERHEAD WARNING LABEL
204	P0857204	CUTTERHEAD EXPOSED LABEL
205	P0857205	ELECTRICITY LABEL
206	P0857206	DISCONNECT POWER LABEL
207	P0857207	CUTTERHEAD GUARD LABEL

REF	PART #	DESCRIPTION
208	P0857208	EYES EARS LUNGS WARNING LABEL
209	P0857209	MODEL NUMBER LABEL (G0857)
209	P0858209	MODEL NUMBER LABEL (G0858)
210	P0857210	GRIZZLY.COM LABEL
211	P0857211	GRIZZLY NAMEPLATE-SMALL
212	P0857212	PANEL CLOSED WARNING LABEL
213	P0857213	TOUCH-UP PAINT, GRIZZLY GREEN
214	P0857214	TOUCH-UP PAINT, GREY PUTTY

! WARNING

Safety labels help reduce the risk of serious injury caused by machine hazards. If any label comes off or becomes unreadable, the owner of this machine **MUST** replace it in the original location before resuming operations. For replacements, contact (800) 523-4777 or www.grizzly.com.

