

Basic Bending Operations

To bend using your bending brake, do these steps:

1. Open both angle clamps and place the workpiece beneath the clamping angle.
2. Close the angle clamps until they snap into place. If the workpiece is too thick or too thin for the clamps, adjust the clamps according to the **Clamp Adjustment** instructions below.
3. When the workpiece is secured in the bending brake, lift the breaker bar levers to form the desired angle.

Clamp Adjustment

To adjust the clamping size, do these steps:

1. Hold the clamping set screw in place with a flat head screwdriver.
2. Screw the adjusting nuts clockwise to adjust for thicker workpieces and counterclockwise to adjust for thinner workpieces. Adjust each clamp an equal amount.

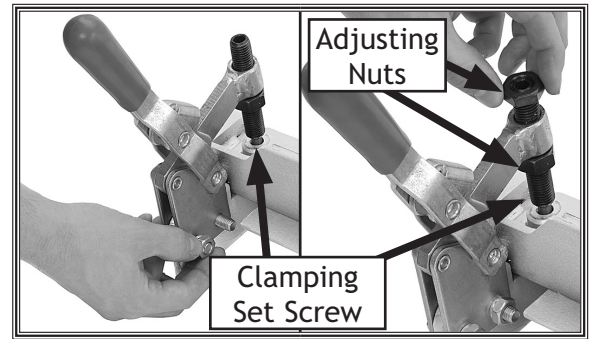
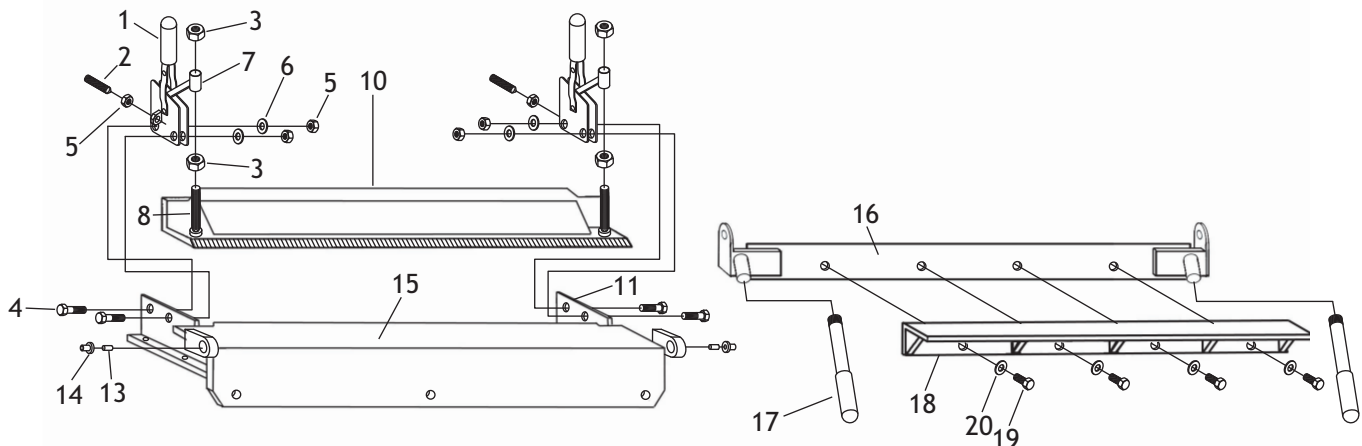

Figure 4. Clamp installation.



Figure 5. Breaker bar lever installation.

M1046 Breakdown and Parts List



REF	PART #	DESCRIPTION
1	XM1046001	CLAMP
2	XPSS39M	SET SCREW M10-1.5 X 50
3	XPN05M	HEX NUT M16-1.5
4	XPB14M	HEX BOLT M10-1.5 X 35
5	XPN02M	HEX NUT M10-1.5
6	XPLW06M	LOCK WASHER 10MM
7	XM1046007	COLLAR
8	XM1046008	ADJUST. SET SCREW M10-1.5 x 90
10	XM1046010	CLAMPING ANGLE

REF	PART #	DESCRIPTION
11	XM1046011	CLAMP MOUNTING PLATE
13	XM1046013	PIVOT PIN 16 X 50
14	XM1046014	FLANGE BEARING
15	XM1046015	BASE
16	XM1046016	BREAKER BAR
17	XM1046017	THREADED LEVER M20-1.75
18	XM1046018	BREAKER ANGLE
19	XPB87M	HEX BOLT M8-1.25 X 15
20	XPW01M	FLAT WASHER 8MM