

PARTS

W1669 & W1670 Parts

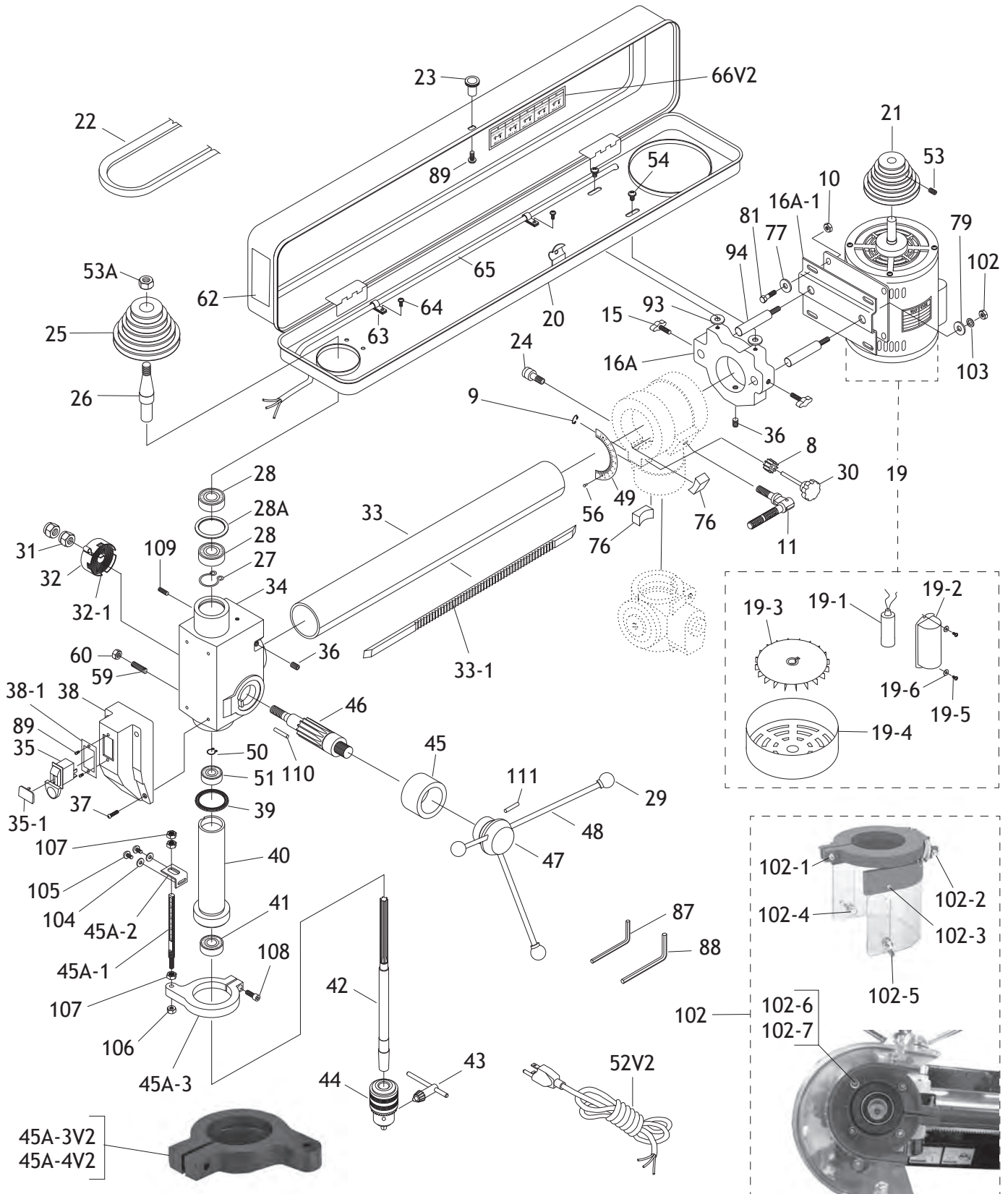



W1669 & W1670 Parts List

REF	PART #	DESCRIPTION
8	X1669008	GEAR
9	X1669009	EXT RETAINING RING 9MM
10	X1669010	HEX NUT M8-1.25
11	X1669011	CLAMP BOLT M10-1.5 X 30
15	X1669015	KNOB BOLT M8-1.25 X 16
16A	X1669016A	MOUNT PLATE V2.10.04
16A-1	X1669016A-1	MOTOR MOUNT PLATE
19	X1669019	MOTOR 1/2 HP, 120V
19-1	X1669019-1	S. CAPCTR 150MFD/125VAC
19-2	X1669019-2	CAPACITOR COVER
19-3	X1669019-3	MOTOR FAN
19-4	X1669019-4	FAN COVER
19-5	X1669019-5	PHLP HD SCR M4-.75 X 6
19-6	X1669019-6	FLAT WASHER 4MM
20	X1669020	PULLEY COVER
21	X1669021	MOTOR PULLEY
22	X1669022	V-BELT 0-1480
23	X1669023	UNTHREADED FEMALE KNOB
24	X1669024	LOCK PIN ASSEMBLY
25	X1669025	SPINDLE PULLEY
26	X1669026	DRIVE SLEEVE
27	X1669027	INT RETAINING RING M40
28	X1669028	BEARING 6203
28A	X1669028A	SPACER
29	X1669029	KNOB
30	X1669030	LEVER
31	X1669031	LOCK NUT 1/2"-20
32	X1669032	COVER WITH SPRING
32-1	X1669032	COVER WITH SPRING
33	X1669033	HORIZONTAL COLUMN
33-1	X1669033-1	HORIZONTAL COLUMN RACK
34	X1669034	HEADSTOCK
35	X1669035	SWITCH AND KEY
35-1	X1669035-1	SWITCH KEY
36	X1669036	SET SCREW 5/16"-18 X 3/8"
37	X1669037	PHLP SCREW 10-24 X 5/8"
38	X1669038	SWITCH BOX
38-1	X1669038-1	SWITCH MOUNTING PLATE
39	X1669039	RUBBER WASHER
40	X1669040	QUILL SHAFT
41	X1669041	BEARING 6202
42	X1669042	SPINDLE JT#33
43	X1669043	CHUCK KEY
44	X1669044	1/2" CHUCK 1-16MM JT#33
45	X1669045	COLLAR
45A-1	X1669045A-1	DEPTH STOP ROD N/S
45A-2	X1669045A-2	DEPTH STOP ROD BRACKET

REF	PART #	DESCRIPTION
45A-3	X1669045A-3	DEPTH STOP MOUNT
46	X1669046	FEED SHAFT
47	X1669047	FEED COLLAR
48	X1669048	HANDLE
49	X1669049	DEGREE SCALE
50	X1669050	EXT RETAINING RING 12M
51	X1669051	BEARING 6201
52	X1669052	POWER CORD
53	X1669053	SET SCREW
53A	X1669053A	PULLEY LOCK NUT V2.01.05
54	X1669054	PHLP SCREW 1/4"-20 X 3/8"
56	X1669056	RIVET
59	X1669059	SPECL SET SCR 5/16"-18 X 1"
60	X1669060	HEX NUT 5/16"-18
62	X1669062	LABEL
63	X1669063	WIRE STRAP
64	X1669064	PHLP SCREW 10-24 X 3/8"
65	X1669065	MOTOR SWITCH CORD
66	X1669066	SPEED CHART
75V2	X1669075	SAFETY LABEL V2.09.17
76	X1669076	LOCKING GIB
77	X1669077	FLAT WASHER 8MM
79	X1669079	FLAT WASHER 12MM
81	X1669081	HEX BOLT M8-1.25 X 20
85	X1669085	SAFETY GOGGLES LABEL
86	X1669086	LONG HAIR SAFETY LABEL
87	X1669087	HEX WRENCH 3MM
88	X1669088	HEX WRENCH 5MM
89	X1669089	SELF TAP SCREW #8 X 3/8"
93	X1669093	RUBBER WASHER 8MM
94	X1669094	GUIDE ROD 16 X 30MM
102	X1669102	HEX NUT M10-1.5
102-1	X1669102-1	PHLP HD SCR M4-.7 X30
102-2	X1669102-2	HEX NUT M4-.7
102-3	X1669102-3	TAP SCREW M2.2 X 4.5
102-4	X1669102-4	HEX BOLT M5-.8 X 12
102-5	X1669102-5	WING NUT M5-.8
102-6	X1669102-6	PHLP HD SCR M4-.7 X 10
102-7	X1669102-7	FLAT WASHER 4MM
103	X1669103	LOCK WASHER 10MM
104	X1669104	FLAT WASHER 6MM
105	X1669105	PHLP HD SCR M6-1 X 10
106	X1669106	HEX NUT M8-1.25
107	X1669107	HEX NUT M10-1.5
108	X1669108	CAP SCREW M8-1.25 X 20
109	X1669109	RUBBER BUMPER
110	X1669110	STRAIN RELIEF M12 TYPE-1 SNAP-IN

W1669 Table & Column

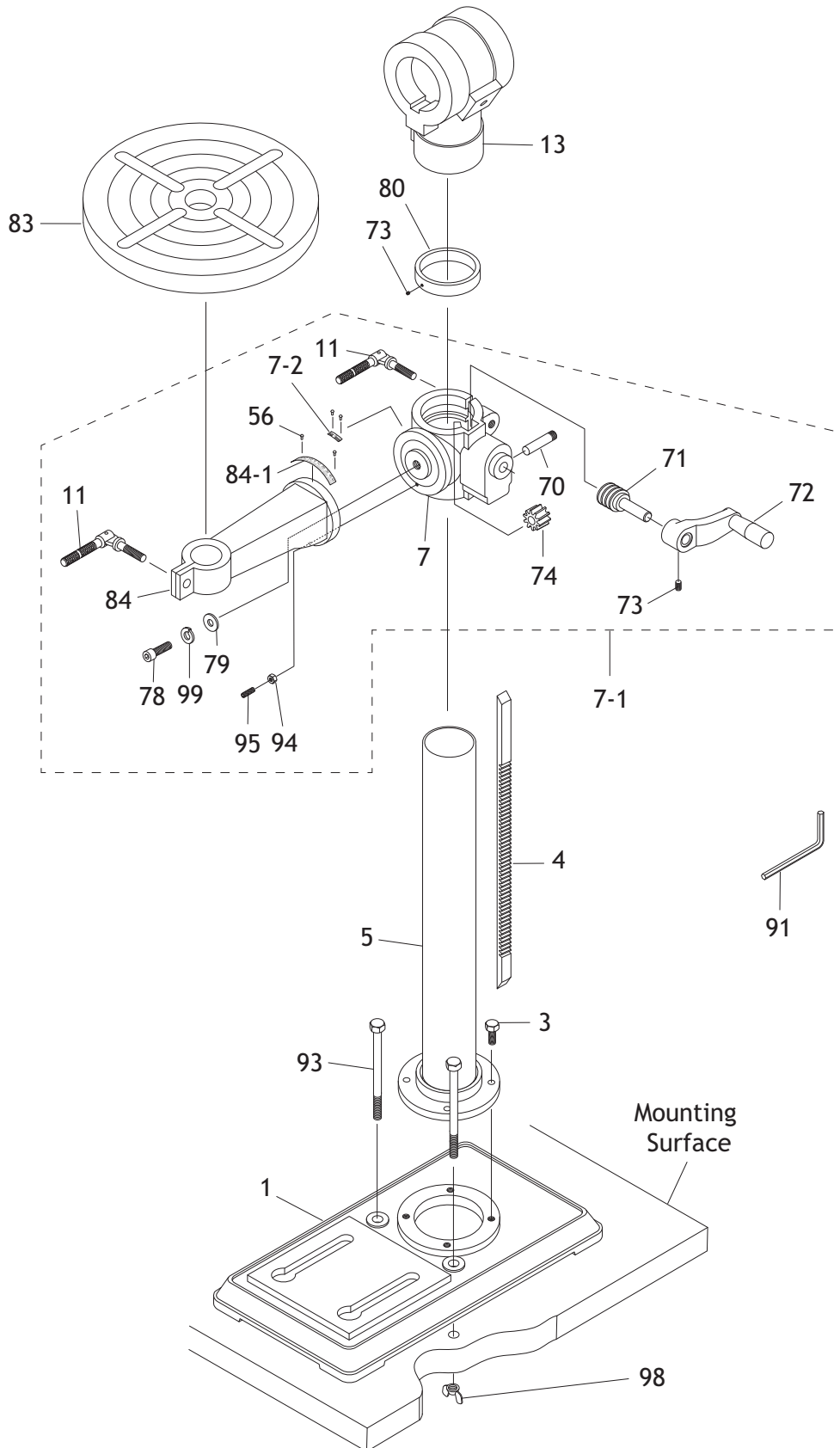

W1669 Table & Column Parts List

REF	PART #	DESCRIPTION
1	X1669001	BASE
3	X1669003	HEX BOLT M8-1.25 X 20
4	X1669004	W1669 RACK
5	X1669005	W1669 COLUMN
7	X1669007	GEARED TABLE BRACKET N/S
7-1	X1669007-1	TABLE BRACKET ASSY
7-2	X1669007-2	DEGREE SCALE
11	X1669011	LOCK LEVER M10-1.5 X 30
13	X1669013	HORIZ. COLUMN BRACKET
54	X1669054	PHLP HD SCR M6-1 X 10
56	X1669056	RIVET
70	X1669070	PIN
71	X1669071	WORM PINION
72	X1669072	LIFT HANDLE CRANK

REF	PART #	DESCRIPTION
73	X1669073	SET SCREW M6-1 X 10
74	X1669074	10T GEAR
78	X1669078	CAP SCREW M12-1.75 X 30
79	X1669079	FLAT WASHER 12MM
80	X1669080	COLUMN RING
83	X1669083	TABLE
84	X1669084	COLUMN SUPPORT ARM N/S
84-1	X1669084-1	TABLE TILT SCALE
91	X1669090	HEX WRENCH 10MM
93	X1669093	HEX BOLT M8-1.25 X 125
94	X1669094	GUIDE ROD 16 X 30MM
95	X1669095	SPECIAL PIN
99	X1669099	LOCK WASHER 12MM
98	X1669098	WING NUT M8-1.25

W1670 Table & Column

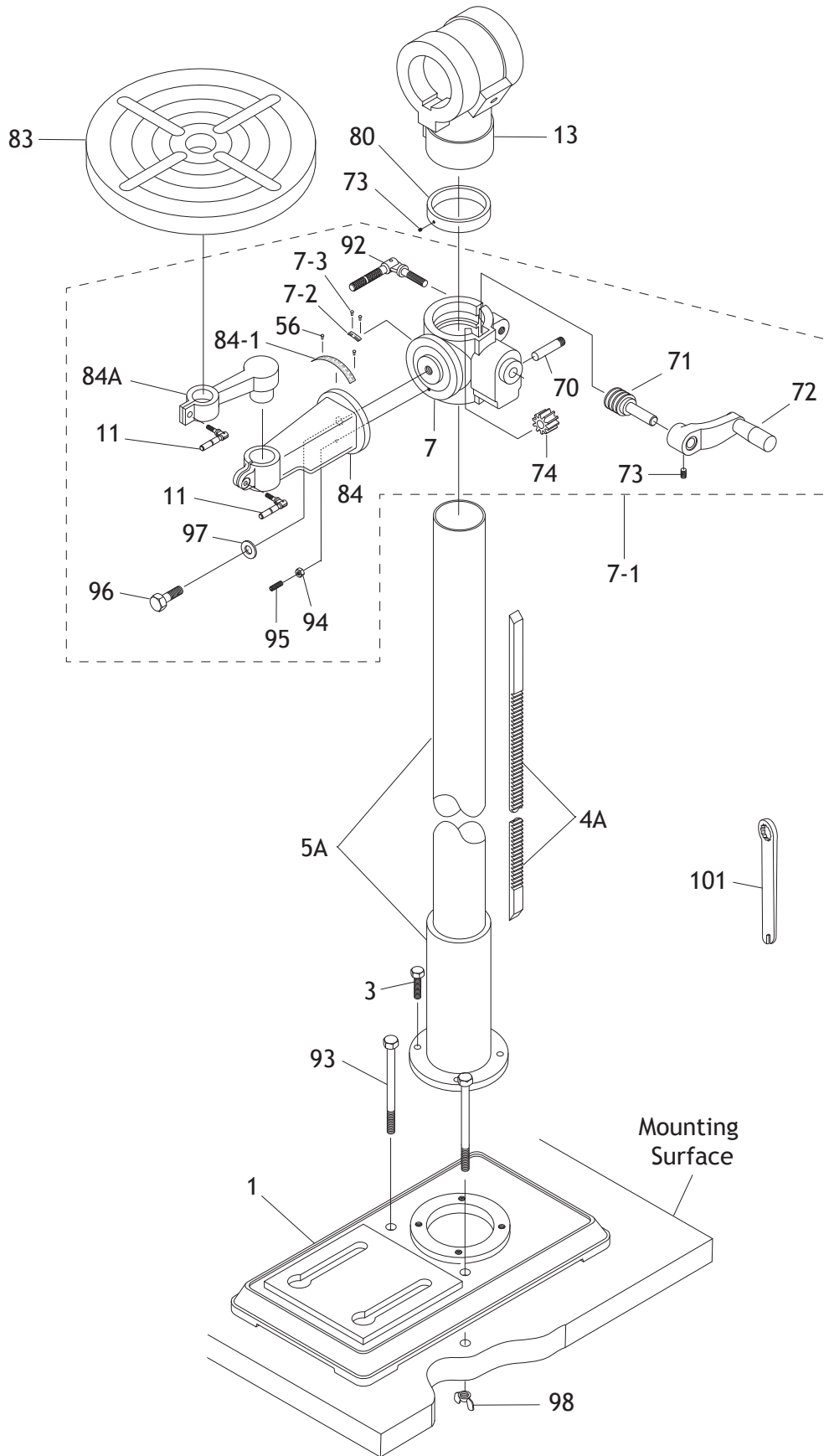

W1670 Table & Column Parts List

REF	PART #	DESCRIPTION
1	X1670001	BASE
3	x1670003	HEX BOLT M8-1.25 X 40
4A	X1670004A	W1670 RACK
5A	X1670005A	W1670 COLUMN
7	X1670007	GEARED TABLE BRACKET N/S
7-1	X1670007-1	TABLE BRACKET ASSY
7-2	X1670007-2	DEGREE SCALE
7-3	X1670007-3	RIVET
11	X1670011	LOCK LEVER M10-1.5 X 30
13	X1670013	HORIZ. COLUMN BRACKET
56	X1670056	RIVET
70	X1670070	AXLE
71	X1670071	WORM PINION
72	X1670072	LIFT HANDLE
73	X1670073	SET SCREW M6-1 X 10

REF	PART #	DESCRIPTION
74	X1670074	WORM GEAR
80	X1670080	COLUMN RING
83	X1670083	TABLE
84	X1670084	COLUMN SUPPORT ARM N/S
84A	X1670084A	TABLE SUPPORT ARM
84-1	X1670084-1	TABLE TILT SCALE
92	X1670092	LOCK LEVER M12-1.75 x 50
93	X1670093	HEX BOLT M8-1.25 X 125
94	X1670094	GUIDE ROD 16 X 30MM
95	X1670095	SPECIAL PIN
96	X1670096	HEX BOLT 5/8-13 X 1-1/2
97	X1670097	FLAT WASHER 5/8
98	X1670098	WING NUT M8-1.25
101	X1670101	SPECIAL WRENCH

W1669 & W1670 Labels & Cosmetics

75V2

<p>MODEL W1669 BENCHTOP RADIAL DRILL PRESS <small>Mfd. for Woodstock in China</small></p>	<p>Specifications</p> <p>Motor: 1/2 HP, 120V, 4.7A, 60 Hz Swing: 34" Spindle Speeds: 550-3470 RPM Spindle to Table Dist.: 12-3/4" Spindle to Base Dist.: 17-1/2" Spindle Travel: 3-1/4" Spindle Taper: JT#33 Weight: 138 lbs.</p>	<p>C 184841</p> <p>Date: _____ Serial #: _____</p>	<p>▲WARNING!</p> <p>To reduce the risk of serious injury when using this machine:</p> <ol style="list-style-type: none"> 1. Read and understand owner's manual before operating. 2. Always wear approved safety glasses. 3. Only plug power cord into a grounded outlet. 4. Disconnect power before setting up or servicing. 5. Tie back long hair, roll up long sleeves, and DO NOT wear loose clothing, gloves, or jewelry. 6. Keep all guards and covers in place during operation. 7. Clamp workpiece to table to prevent rotation. 8. Avoid putting hands where they could slip into rotating bits. 9. Always remove chuck keys and other tools before starting. 10. Use correct speeds for drilling accessories and workpiece. 11. Do not expose to rain or use in wet locations. 12. Prevent unauthorized use by children or untrained users.
--------------------------------------------------------------------------------------------------------------	----------------------------------------------------------------------------------------------------------------------------------------------------------------------------------------------------------------------------------------------------------------------	--------------------------------------------------------	-------------------------------------------------------------------------------------------------------------------------------------------------------------------------------------------------------------------------------------------------------------------------------------------------------------------------------------------------------------------------------------------------------------------------------------------------------------------------------------------------------------------------------------------------------------------------------------------------------------------------------------------------------------------------------------------------------------------------------------------------------------------------------------------------------------------------------------------------------------------------------------------------------------------------------------------------------------------------------

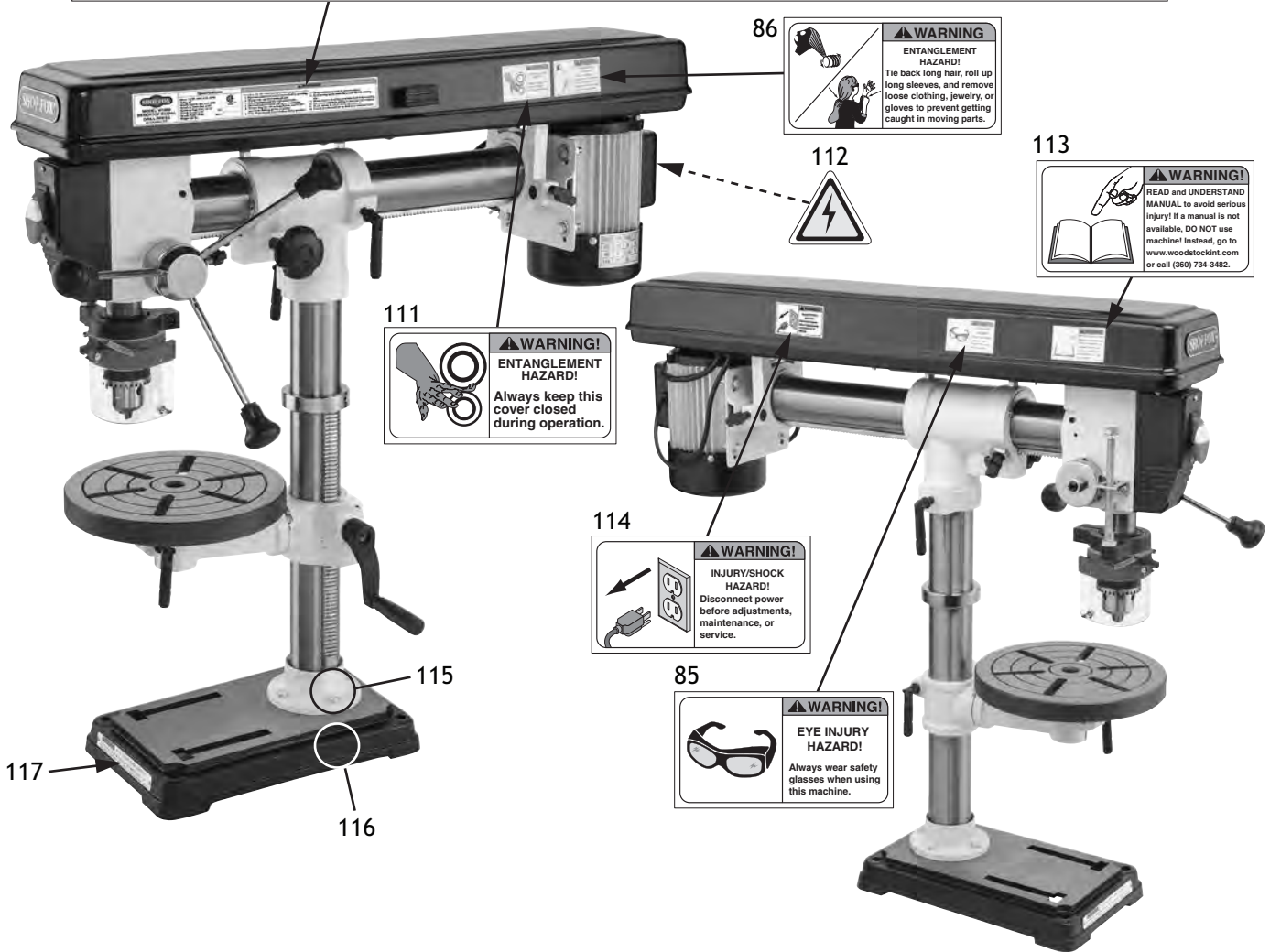

REF	PART #	DESCRIPTION
75V2	X1669075V2	MACHINE ID LABEL CSA V2.09.17 (W1669)
75V2	X1670075V2	MACHINE ID LABEL CSA V2.09.17 (W1670)
85	X1669085	EYE INJURY WARNING LABEL
86	X1669086	ENTANGLEMENT WARNING LABEL
111	X1669111	PINCH HAZARD WARNING LABEL
112	X1669112	ELECTRICITY WARNING LABEL

REF	PART #	DESCRIPTION
113	X1669113	READ MANUAL WARNING LABEL
114	X1669114	DISCONNECT POWER LABEL
115	X1669115	TOUCH-UP PAINT, SHOP FOX WHITE
116	X1669116	TOUCH-UP PAINT, SHOP FOX BLACK
117	X1669117	TIPPING HAZARD LABEL

▲WARNING

Safety labels warn about machine hazards and how to prevent serious personal injury. The owner of this machine **MUST** maintain the original location and readability of all labels on this machine. If any label is removed or becomes unreadable, **REPLACE** that label before allowing machine to be operated again. Contact us at (360) 734-3482 or www.woodstockint.com to order new labels.