

Parts

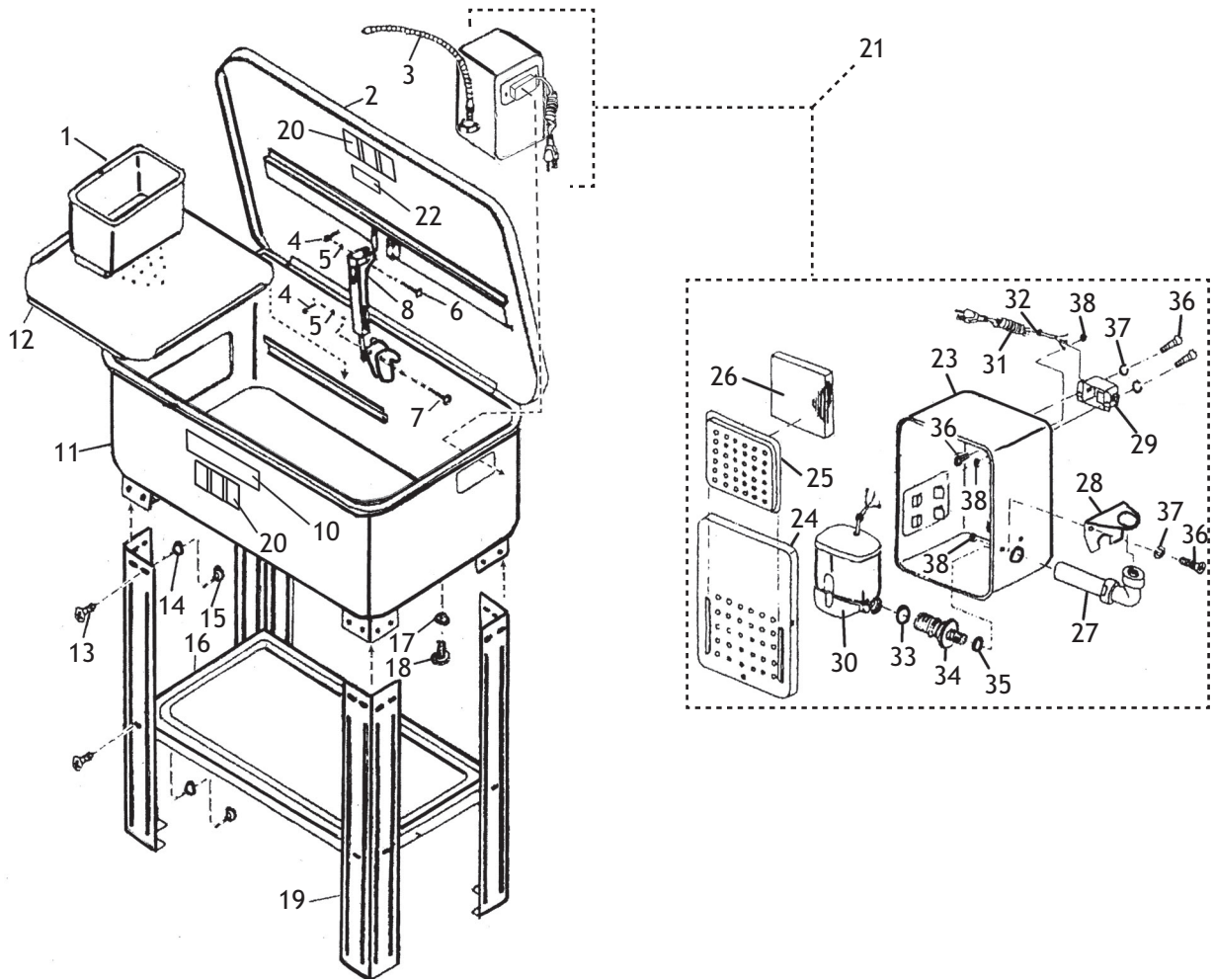

REF	PART #	DESCRIPTION
1	X1760001	PARTS BIN
2	X1760002	LID
3	X1760003	FLEX HOSE W/NOZZLE
4	X1760004	COTTER PIN 1.5 X 16
5	XPW02M	FLAT WASHER 5MM
6	X1760006	CLEVIS PIN 5 X 30
7	X1760007	CLEVIS PIN 5 X 20
8	X1760008	FIRE FUSE LINK ASSEMBLY
10	X1760010	DATA LABEL
11	X1760011	TUB
12	X1760012	WORK TABLE
13	XPS14M	PHLP HD SCR M6-1 X 12
14	XPLW03M	LOCK WASHER 6MM
15	XPNO1M	HEX NUT M6-1
16	X1760016	SHELF
17	X1760017	RUBBER WASHER
18	X1760018	DRAIN PLUG
19	X1760019	LEG
20	X1760020	COMBO WARNING LABEL

REF	PART #	DESCRIPTION
21	X1760021	COMPLETE PUMP BOX W/ELECTRICAL
22	X1760022	WATER SHOCK LABEL
23	X1760023	PUMP BOX
24	X1760024	PUMP BOX COVER
25	X1760025	FILTER RETAINER COVER
26	X1760026	FIBER FILTER
27	X1760027	OUTPUT PIPE W/ELBOW
28	X1760028	ELBOW SUPPORT BRACKET
29	X1760029	SWITCH BOX W/SWITCH
30	X1760030	SOLVENT PUMP 110V
31	X1760031	POWER CORD 110V
32	X1760032	GROMMET
33	XPORP021	O-RING 20.8 X 2.4 P21
34	X1760034	OUTPUT TUBE
35	XPORP015	O-RING 14.8 X 2.4 P15
36	XPS38M	PHLP HD SCR M4-.7 X 10
37	XPW05M	FLAT WASHER 4MM
38	XPNO4M	HEX NUT M4-.7

Label Placement

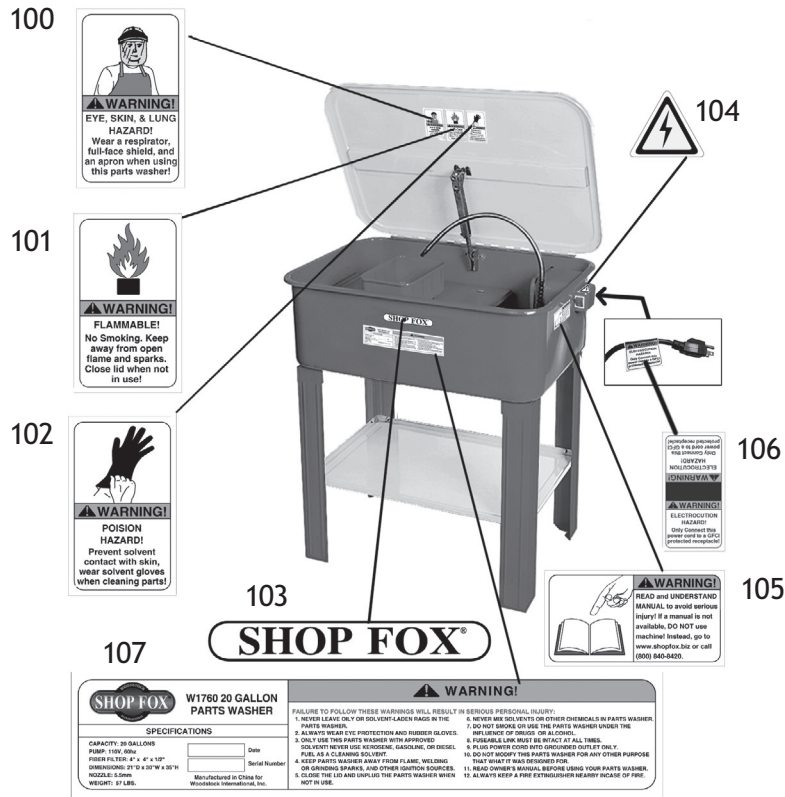

REF	PART #	DESCRIPTION
100	X1760100	EYE SKIN HAZARD LABEL
101	X1760101	FLAMMABLE WARNING LABEL
102	X1760102	RUBBER GLOVES WARNING LABEL
103	X1760103	SHOP FOX LABEL

REF	PART #	DESCRIPTION
104	XLABEL-04S	ELECTRICITY WARNING LABEL
105	XLABEL-08H	READ MANUAL LABEL
106	X1760106	GFCI WARNING LABEL
107	X1760107	DATA LABEL