

PARTS

Main

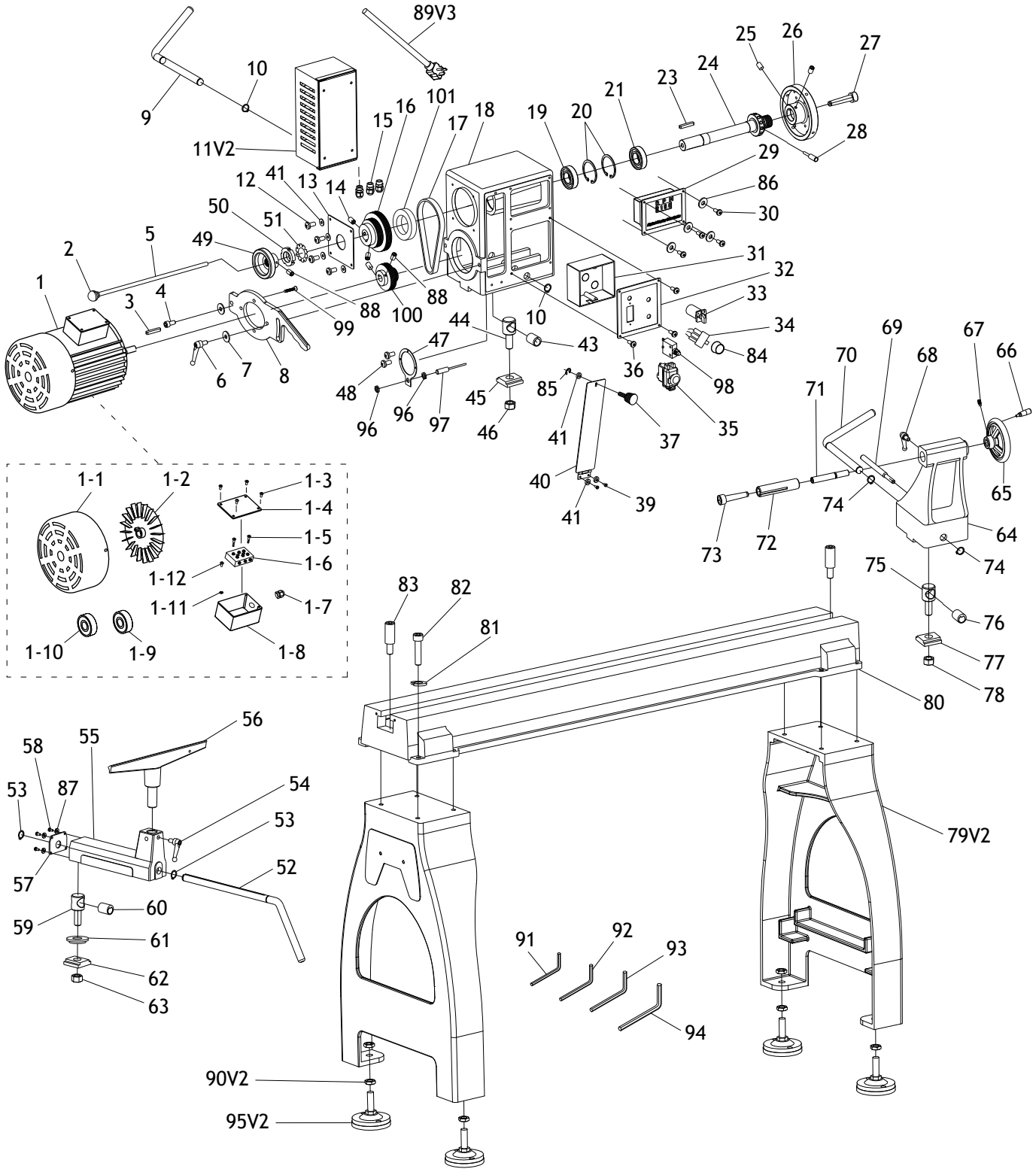

Main Parts List

REF	PART #	DESCRIPTION
1	X1852001	MOTOR 3HP 240V 3-PH
1-1	X1852001-1	MOTOR FAN COVER
1-2	X1852001-2	MOTOR FAN
1-3	X1852001-3	TAP SCREW M4-.7 X 18
1-4	X1852001-4	MOTOR TERMINAL BOX COVER
1-5	X1852001-5	PHLP HD SCR M4-.7 X 20
1-6	X1852001-6	MOTOR TERMINAL
1-7	X1852001-7	STRAIN RELIEF PG13.5 TYPE-3
1-8	X1852001-8	MOTOR TERMINAL BOX
1-9	X1852001-9	BALL BEARING 6205ZZ (FRONT)
1-10	X1852001-10	BALL BEARING 6204ZZ (REAR)
1-11	X1852001-11	FLAT WASHER 4MM
1-12	X1852001-12	PHLP HD SCR M4-.7 X 8
2	X1852002	ROUND KNOB M8-1.25
3	X1852003	KEY 6 X 6 X 60
4	X1852004	CAP SCREW M10-1.5 X 30
5	X1852005	KNOCKOUT ROD M8-1.25 X 14, 369L
6	X1852006	BELT TENSION LOCK LEVER
7	X1852007	FENDER WASHER 10MM
8	X1852008	MOTOR PLATE
9	X1852009	HEADSTOCK LOCK LEVER
10	X1852010	EXT RETAINING RING 19MM
11V2	X1852011V2	INVERTER DELTA VFD11AMS21ANSAA V2.01.20
12	X1852012	PHLP HD SCR M5-.8 X 12
13	X1852013	SPINDLE PULLEY COVER
14	X1852014	SET SCREW M8-1.25 X 10
15	X1852015	STRAIN RELIEF PG13.5 TYPE-3
16	X1852016	SPINDLE PULLEY
17	X1852017	V-BELT 220J6
18	X1852018	HEADSTOCK CASTING
19	X1852019	BALL BEARING 6206ZZ
20	X1852020	INT RETAINING RING 62MM
21	X1852021	BALL BEARING 6206ZZ
23	X1852023	KEY 8 X 8 X 45
24	X1852024	SPINDLE
25	X1852025	SET SCREW M6-1 X 12 DOG-PT
26	X1852026	FACEPLATE 153MM DIA
27	X1852027	SPUR CENTER
28	X1852028	INDEXING PIN
29	X1852029	DIGITAL READOUT
30	X1852030	PHLP HD SCR M4-.7 X 8
31	X1852031	SWITCH BOX
32	X1852032	PANEL COVER
33	X1852033	ROTARY SWITCH KEDU ZH-A FOR/OFF/REV
34	X1852034	POTENTIOMETER WX110 B10K
35	X1852035	ON/OFF SWITCH KJD178 250V 18A
36	X1852036	PHLP HD SCR M4-.7 X 6
37	X1852037	KNURLED THUMB SCREW M5-.8 X 8
39	X1852039	PHLP HD SCR M5-.8 X 8
40	X1852040	BELT DOOR
41	X1852041	FLAT WASHER 5MM
43	X1852043	BUSHING
44	X1852044	HEADSTOCK CLAMP BOLT M18-2.5 X 44
45	X1852045	HEADSTOCK CLAMP
46	X1852046	HEX NUT M18-2.5

REF	PART #	DESCRIPTION
47	X1852047	RPM SENSOR BRACKET
48	X1852048	PHLP HD SCR M4-.7 X 8
49	X1852049	HANDWHEEL 49MM DIA DISHED
50	X1852050	SPANNER NUT M30-1.5
51	X1852051	SPANNER NUT WASHER 30MM
52	X1852052	TOOL REST BASE LOCK LEVER
53	X1852053	EXT RETAINING RING 19MM
54	X1852054	TOOL REST LOCK LEVER
55	X1852055	TOOL REST BASE (BANJO), 1" HOLE
56	X1852056	TOOL REST, 1" POST
57	X1852057	TOOL REST BASE PLATE
58	X1852058	PHLP HD SCR M5-.8 X 12
59	X1852059	TOOL REST CLAMP BOLT M18-2.5 X 44
60	X1852060	ECCENTRIC BUSHING
61	X1852061	SLIDE BUSHING
62	X1852062	CLAMP PLATE
63	X1852063	HEX NUT M18-2.5
64	X1852064	TAILSTOCK CASTING
65	X1852065	HANDWHEEL 137MM DIA DISHED
66	X1852066	HANDWHEEL HANDLE M8-1.25 X 13, 94L
67	X1852067	SET SCREW M8-1.25 X 12
68	X1852068	QUILL LOCK LEVER
69	X1852069	STOP PIN M8-1.25 X 10, 152L
70	X1852070	TAILSTOCK LOCK LEVER
71	X1852071	LEADSCREW
72	X1852072	QUILL
73	X1852073	LIVE CENTER
74	X1852074	EXT RETAINING RING 19MM
75	X1852075	TAILSTOCK CLAMP BOLT M18-2.5 X 44
76	X1852076	ECCENTRIC BUSHING
77	X1852077	CLAMP PLATE
78	X1852078	HEX NUT M18-2.5
79V2	X1852079V2	STAND V2.01.21
80	X1852080	BED
81	X1852081	LOCK WASHER 10MM
82	X1852082	CAP SCREW M10-1.5 X 35
83	X1852083	BED STOP
84	X1852084	VARIABLE SPEED DIAL
85	X1852085	E-CLIP 5MM
86	X1852086	FLAT WASHER 4MM
87	X1852087	LOCK WASHER 5MM
88	X1852088	SET SCREW M6-1 X 10
89V3	X1852089V3	POWER CORD 12G 3W 72" 6-20P 90-DEG V3.01.21
90V2	X1852090V2	HEX NUT M16-2 V2.01.21
91	X1852091	HEX WRENCH 3MM
92	X1852092	HEX WRENCH 4MM
93	X1852093	HEX WRENCH 6MM
94	X1852094	HEX WRENCH 8MM
95V2	X1852095V2	ADJ FOOT M16-2 X 50, 100D V2.01.21
96	X1852096	HEX NUT M12-1.5 THIN
97	X1852097	CONDUIT M12-1.5 X 35
98	X1852098	CIRCUIT BREAKER GEN. IND. 220V 15A
99	X1852099	FLAT HD CAP SCR M8-1.25 X 20
100	X1852100	MOTOR PULLEY
101	X1852101	PULLEY SPACER

Labels & Cosmetics

⚠️ WARNING

Safety labels warn about machine hazards and how to prevent serious personal injury. The owner of this machine **MUST** maintain the original location and readability of all labels on this machine. If any label is removed or becomes unreadable, **REPLACE** that label before allowing machine to be operated again. Contact us at (360) 734-3482 or www.woodstockint.com to order new labels.

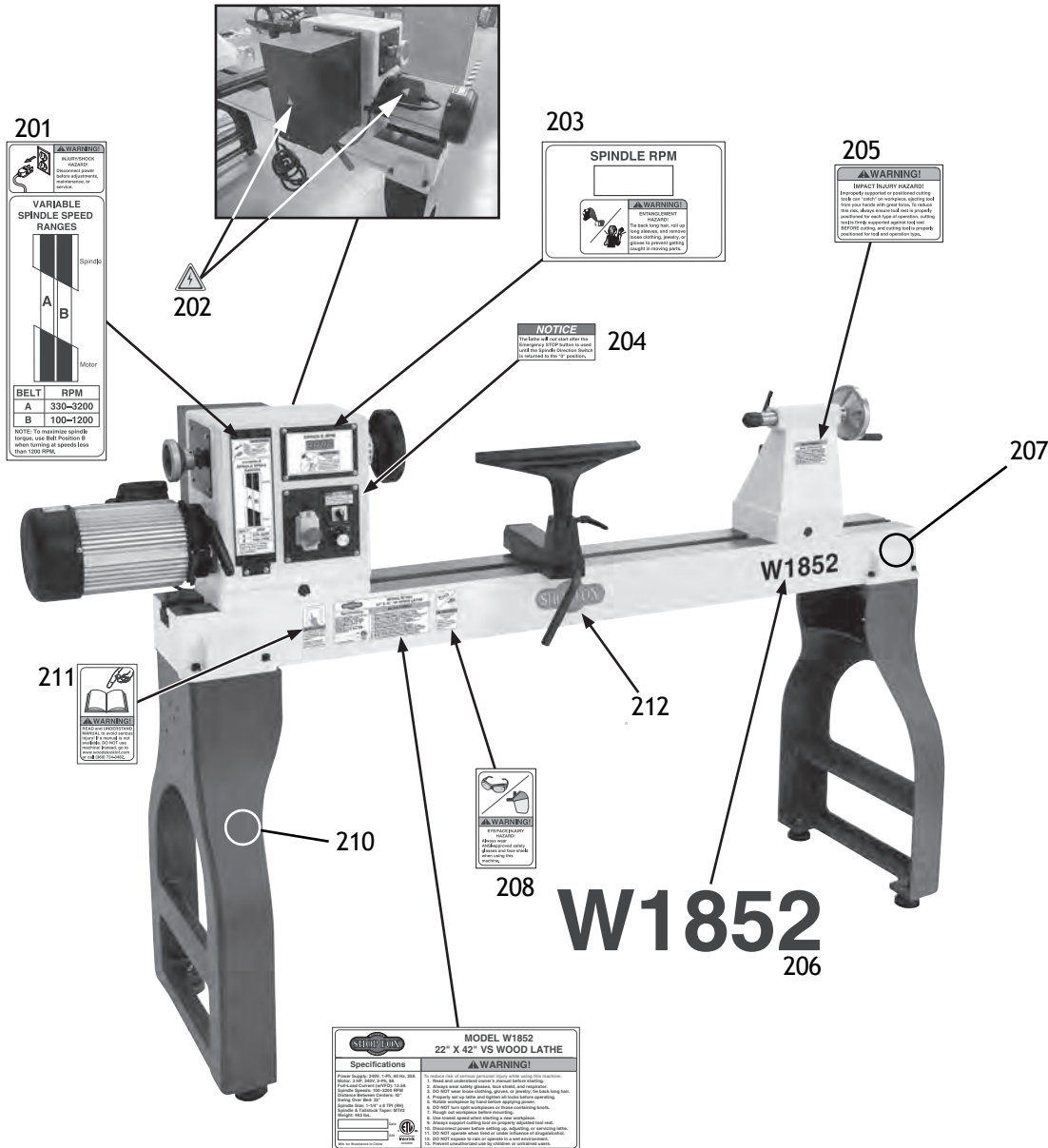

REF	PART #	DESCRIPTION
201	X1852201	SPINDLE SPEED CHART
202	X1852202	ELECTRICITY LABEL
203	X1852203	SPINDLE RPM LABEL
204	X1852204	SPINDLE DIRECTION SWITCH NOTICE
205	X1852205	IMPACT INJURY WARNING LABEL
206	X1852206	MODEL NUMBER LABEL

REF	PART #	DESCRIPTION
207	X1852207	SHOP FOX WHITE PAINT
208	X1852208	EYE/FACE INJURY HAZARD LABEL
209V2	X1852209V2	MACHINE ID LABEL V2.01.20
210	X1852210	SHOP FOX BLACK PAINT
211	X1852211	READ MANUAL LABEL
212	X1852212	SHOP FOX NAMEPLATE